



Tube & Pipe Tools

Leading manufacturer of high quality tools and machines for the tube and pipe industry

PRODUCTS CATALOG 2026



Condenser expanders



Boiler expanders



Rolling controls



Basic tools



Tube Plugs



FinFan applications



Beveling tubes



Beveling pipes



Flange facers



Tube cutters



Tube pulling



Accessories

Tube & Pipe Professional Tools





Tube & Pipe Tools

Catalog 2026





Certificate of Registration

QUALITY MANAGEMENT SYSTEM - ISO 9001:2015

This is to certify that:

KRAIS
Przedsiębiorstwo Produkcyjno Remontowe
Jerzy Krajs
Czachowo 15
Zawonia
55-106
Poland

Holds Certificate No:

FM 720649

and operates a Quality Management System which complies with the requirements of ISO 9001:2015 for the following scope:

Production of tools and equipment for pipe processing and installation.
Activities are related to IAF Sector 17.

For and on behalf of BSI:

David Fardel

David Fardel, Country Manager, EMEA Assurance

Original Registration Date: 2019-11-18

Latest Revision Date: 2025-10-01

Effective Date: 2025-11-18

Expiry Date: 2028-11-17



Page: 1 of 1

...making excellence a habit.™

This certificate was issued electronically and remains the property of BSI and is bound by the conditions of contract.
An electronic certificate can be authenticated [online](#).
Printed copies can be validated at www.bsigroup.com/ClientDirectory

Information and contacts: BSI Group Italia srl, via Gaetano De Castilla 23, Milano, Italy, phone: +39 02 4441 8150
A Member of the BSI Group of Companies.

Table of contents

<p>Correct expansion guide → 6</p>	<p>Typical thrust collars → 10</p>	<p>Rolls for condenser expanders → 11</p>	<p>900 Series → 12</p> 	<p>1300 Series → 13</p> 	<p>800 Series → 14</p> 
<p>800-5 Five Roll Series → 17</p> 	<p>1200 Series → 19</p> 	<p>1200-5 Five Roll Series → 22</p> 	<p>8012 Series → 24</p> 	<p>F600 Flare Type Series → 26</p> 	<p>TACK Conical Series → 27</p> 
<p>Special expanders → 28</p> 	<p>KS Series → 34</p> 	<p>PZ Series → 37</p> 	<p>FTKS-L Flare Type Series → 39</p> 	<p>P2 Series → 41</p> 	<p>UCRB Series → 43</p> 
<p>Colins Expander → 44</p> 	<p>K20 Series → 46</p> 	<p>Push&Pull K50 Series → 46</p> 	<p>AK50 Automatic Rolling Motor → 46</p> 	<p>K60 Series → 47</p> 	<p>AK60NS Automatic Rolling Motor → 47</p> 
<p>K70 Right Angle Series → 48</p> 	<p>K77 Right Angle Series → 48</p> 	<p>FlexHolder System → 49</p> 	<p>TES Mini 2 → 50</p> 	<p>TES-2000 Digital Expanding System → 52</p> 	<p>TES-3000 Digital Expanding System → 54</p> 
<p>SwiftRoll Series → 57</p> 	<p>Tube Hole Gauge → 60</p> 	<p>KVLD-3000 Vacuum Leak Tester → 61</p> 	<p>TEF - Tube End Facer → 62</p> 	<p>Tool for serrating Tube Sheet → 62</p> 	<p>MWR-JGS Mini Grooving Tool → 63</p> 
<p>Grooving tools for MWR-JGS → 64</p> 	<p>MiniDrill → 65</p> 	<p>MicroDrill → 66</p> 	<p>SPS - Smart plugging system → 68</p> 	<p>Tube Plugs T_APPL HEP Series → 70</p> 	<p>Tube Plugs T_APPL FFF Series → 71</p> 
<p>One piece tube plugs → 73</p>	<p>MiniDrill GFF → 76</p> 	<p>MiniMill 300GFF → 78</p> 	<p>MiniMill 300FF → 80</p> 	<p>FinMill → 82</p> 	<p>QuickFacer → 88</p> 

Table of contents

MiniMill 101 → 90 	MiniMill 201 → 92 	MiniMill 301LP → 94 	PrepMill → 96 	HyperMill 56 → 98 	PipeMill-8 → 100 
SmartMill-8 → 102 	PanelMill 65 → 104 	PanelDrill → 106 	PanelMill PF → 108 	Cutters and inserts → 110 	Holders for regular cutter heads → 111 
MiniMill Special Heads → 115 	PrepMill and HyperMill Special Heads → 118 	Holders for PanelMill heads → 120 	MiniLathe → 122 	PipeLathe 24 → 124 	PipeLathe 40 → 126 
SlimFit Split Frame Clamshells → 127 	SFSF clamshells motors → 129 	Clamshell K70 Drives → 130 	Reaction ring for SFSF clamshells → 131 	SFSF clamshells add-ons → 132 	SFSF clamshells bits and holders → 133 
Manual FlangeMill → 136 	MFM-OMM Module → 137 	Manual FlangeMill Long → 138 	MFF-125, Mini Flange Facer → 139 	NBFF – Narrow Body Flange Facer → 141 	OMFM-305 → 143 
IMFM-24/30 → 145 	IMFM-24 Internal Mounted FlangeMill → 147 	IMFM-40 Internal Mounted FlangeMill → 148 	IMFM-60 Internal Mounted FlangeMill → 150 	SFFM Flange Facer → 151 	SFFM Module → 152 
MicroDrill-SOFD → 153 	MiniCut 100 for heat exchangers → 156 	MiniCut 300 for condenser and chillers → 156 	MiniCut 101/AF with automatic feed → 157 	Tube Cutters for MiniCut Machines → 157 	HyperCut → 158 
KDM Pneumatic drill → 159 	PTTC Universal → 159 	PTTT - Tube trimmer → 159 	Solid body PTTC → 160 	ORTC - One Revolution Tube Cutter → 161 	1WTTTC-1000 Wheel Type Tube Cutter → 162 

Table of contents

<p>2WTTC-1500 Two Wheels Type Tube Cutter → 166</p> 	<p>3WTTC-2000 Three Wheels Type Tube Cutter → 168</p> 	<p>3WTTC-3000 Three Wheels Tube Cutter → 170</p> 	<p>MWTTC – Manual Tube Cutter → 171</p> 	<p>Tube wall reducing tool → 173</p> 	<p>Modular tube wall reducing tool → 174</p> 
<p>MiniMill-301-WTRT → 175</p> 	<p>MiniDrill-500-WTRT → 176</p> 	<p>Pneumatic Chipping hammer → 178</p> 	<p>CT Collapsing tool → 178</p> 	<p>TD Tube drift → 178</p> 	<p>HyperDrill BSR → 179</p> 
<p>HETT – Tube Taping Machine → 182</p> 	<p>Manual Tube Puller → 183</p> 	<p>MSP-100 Manual Spear Puller → 183</p> 	<p>MCP-100 Manual Collet Puller → 184</p> 	<p>Tube Puller HCP-5T → 185</p> 	<p>Tube Puller CP-1200 → 186</p> 
<p>Tube Puller CP-1200-CC → 187</p> 	<p>Tube Puller CP-1200-FF → 188</p> 	<p>Tube Puller HPR20-CP1000 → 189</p> 	<p>HPR-CP2000 Tube Puller → 191</p> 	<p>Super-Jenny Semi-Automatic Tube Puller → 193</p> 	<p>ACTP - Automatic, continous tube pulling → 194</p> 
<p>HPR Tube Pullers → 196</p> 	<p>HPR-20 Tube Puller → 196</p> 	<p>HPR-30 Tube Puller → 196</p> 	<p>Tube SpinAIR → 198</p> 	<p>Pumps → 199</p> 	<p>Accessories → 202</p> 
<p>Testing pumps → 204</p> 	<p>Charts → 208</p>				

IMPORTANT!

Due to constant improvement of products presented in this catalog, the data and part numbers may change without further notice!
Most tools are available in custom-made versions. If your work requires a special solution - contact us, we will prepare a special tool.

The tube capacities given for expansion tools in this catalog, apply only for most popular cases with a standard percentage of the wall reduction. The reached capacity can be different for thicker tube sheet, harder and exotic metal tube and a higher percentage of wall reduction.

The recommended operating ranges of all cutting tools are suitable for standard pipe sizes and materials. The processing of pipes made of non-standard materials or of non-standard dimensions should be carried out after testing and with great care.

Correct expansion guide

EXPANSION FORMULA

The following formula will help you to choose the right Expander and make the right expansion.

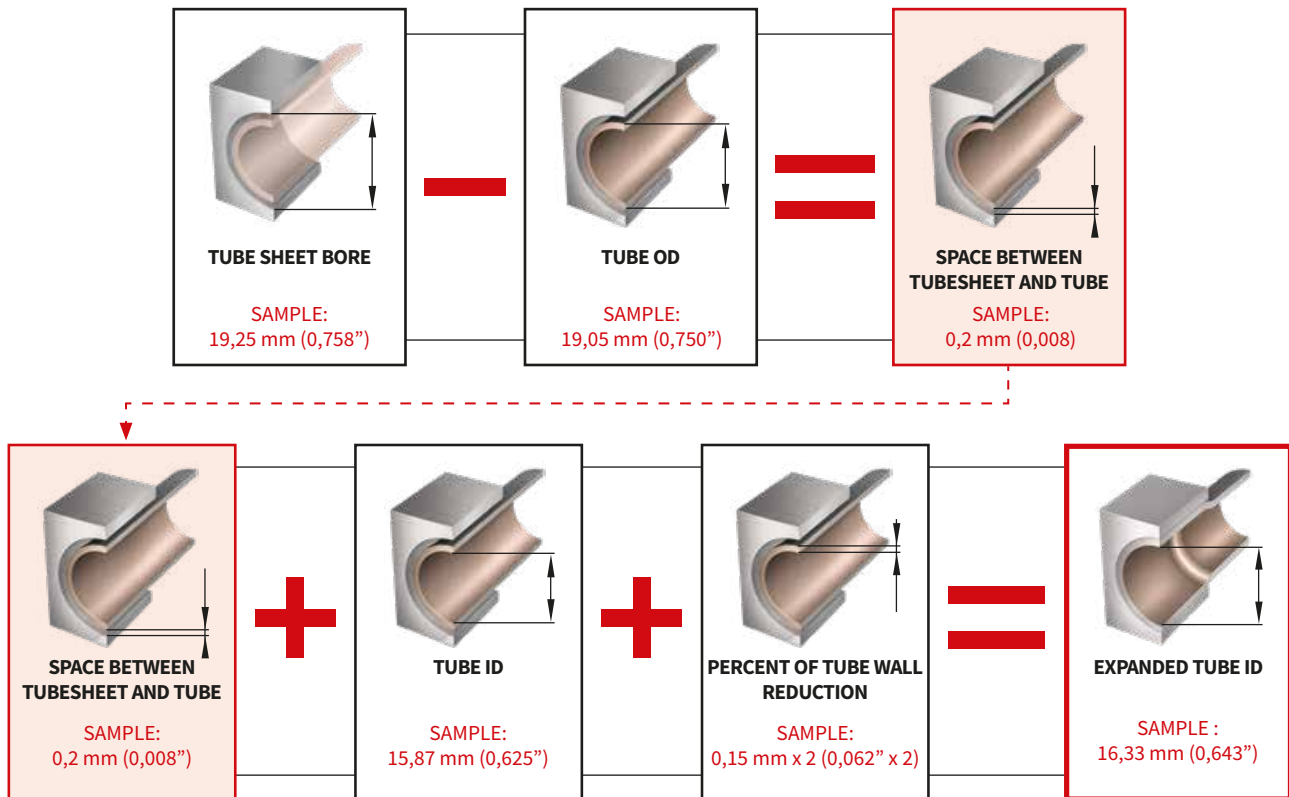

Percentage wall reduction is the most frequently used procedure to obtain the optimal mechanical joint between a Tube and Tube Sheet.

In order to calculate this reduction we must take into account the variances between the Tube OD, Tube Wall Thickness and Tube Sheet Hole Diameter. We must also consider the differing types of materials being used for both Tubes and Tube Sheets, however as a general rule, percentage wall reduction ranges between 4% - 10%.

The table illustrates the applicable percentage tube wall reductions according to the differing materials commonly used for both Tubes and Tube Sheets:

TUBE SHEET MATERIAL	TUBE MATERIAL	TUBE WALL REDUCTION
Stainless Steel	Stainless Steel	4-5%
Steel	Stainless Steel	4-5%
Steel	Steel	7%
Steel	Copper	5%
Copper	Copper	10%

For boilers tube wall thickness reduction varies between 8-16%.

ANATOMY OF ROLL

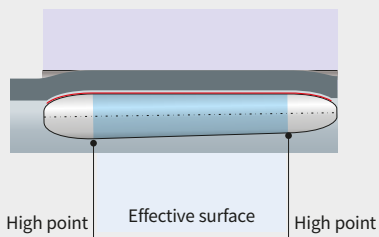

TUBE ROLLING SETUP GUIDE

The following suggestions are offered to aid in the setting up process for rolling tubes into a heat exchanger or boiler. A good start assures good end results:

1. Pick 3 to 5 tubes in the unit to be rolled and complete the formula on the page A-1. It is important that the Measurements used in the set-up are actual, never use averaged dimensions.
2. After the worksheet is finished, start setting up the torque control motor by test rolling the first of the 5 tubes. The first test roll must be done with the airetrol or electric rolling motor set for low torque to avoid over rolling.

NOTE!

Re-roll all test tubes that were under size. To ensure the best tool life and the highest quality tube to tube sheet contact, periodic cleaning of the expander is necessary. Proper lubrication of the rolls, mandrel and thrust bearing is a must!

3. Measure the tube ID after rolling. If more expansion is needed, increase the torque setting on the control and roll the second tube. Check the finished ID this step may have to be repeated on tube # 3. By this time, the torque setting should be correct.
4. Roll tubes 4 and 5 to double check the set-up. These tubes should measure as calculated within the allowable tolerance.

Condenser tubes	10-17 BWG +/- 0.001"
Condenser tubes	18-24 BWG +/- 0.0005"
Boiler tubes	4-10 BWG +/- 0.002"
Boiler tubes	12-16 BWG +/- 0.001"
5. The rolling control is now set and ready to roll the rest of the tubes in the unit. The use of the torque control system will ensure the uniform tightness of all tubes.

SETTING CONDENSER EXPANDER

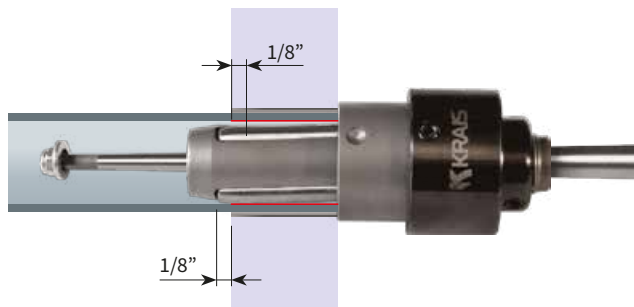

Locate high point of roll approx 1/8" inside back of tube sheet and thrust collar must be touching tube sheet.

SETTING BOILER EXPANDER

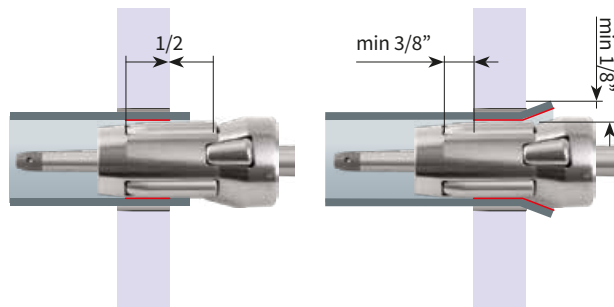

Short straight roll set approx half way into tube sheet. Tube rolled 3/8" back of tube sheet. Flared tube diameter 1/8" larger than tube sheet hole.

BOILER TUBE INSTALLATION CODE

The ends of all tubes, suspension tubes and nipples in water-tube boilers and superheaters shall project through the tube sheets or headers by not less than 1/4" and not more than 3/4" before flaring. Where tubes enter at an angle, the maximum projection of 3/4" applies only at the point of least projection.

Tubes shall be expanded and flared to an outside diameter at least 1/8" greater than the tube-hole diameter. As an alternative, tubes may be flared, rolled and welded, except as provided in PWT-11.2. Tubes may also be rolled and seal welded without flaring, provided that the throat of the seal weld is not more than 3/8" and the tubes are re-expanded after welding.

KEY INSTALLATION LIMITS:

- ▶ Tube projection inside the drum: 1/4" minimum and 3/4" maximum.
- ▶ Outside diameter of the flare: 1/8" larger than the tube-sheet hole.
- ▶ Rolling depth: 1/4" to 3/8" past the back of the tube sheet.

DETAILED BOILER TUBE EXPANSION AND FLARING TECHNICAL SEQUENCE

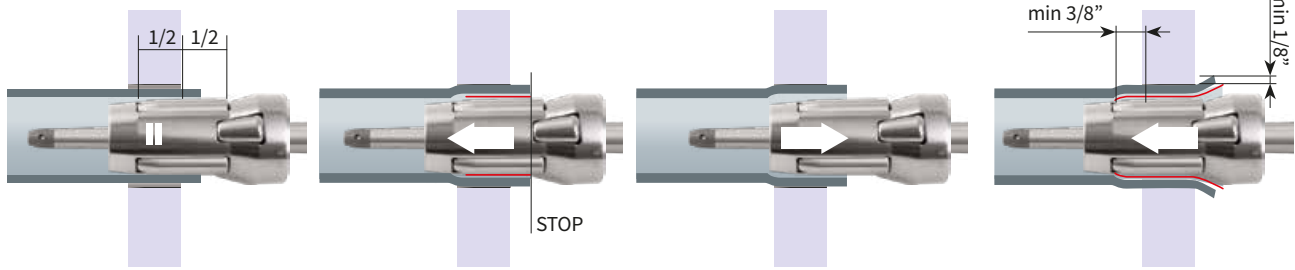

Phase 1: initial positioning and primary roll. Insert the expander into the tube until the rollers reach approximately half of their effective length. This ensures a stable start for the torque-controlled expansion process.

Phase 2: full-length expansion cycl. Proceed with rolling the tube to the full effective length of the expansion rollers. It is critical to terminate the rolling operation immediately before the flaring section engages to maintain metallurgical integrity.

Phase 3: retraction and quality verification. Completely retract the expander from the tube bore. If necessary, repeat the operation to ensure the tube wall reduction meets the calculated engineering specifications.

Phase 4: final flaring stage. Once the final expansion is achieved, drive the expander into the tube for the final step. Continue the process until the desired flare geometry is fully achieved, ensuring a leak-proof bell-mouth joint.

STEP ROLLING (THICK TUBE SHEET)

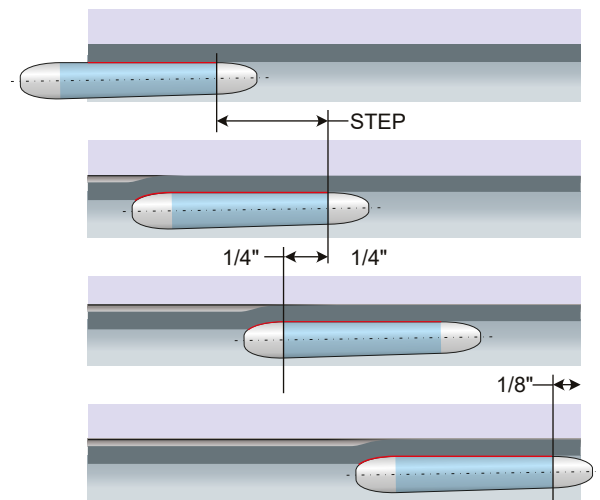

To determine length of steps, divide the estimated number of steps into the length of area to be rolled. This length must be at least 1/4" shorter than the effective length of the "2R" roll.
1-1/2" long rolls have maximum effective length of 1"; 2-1/4" long rolls have maximum effective length of 1-3/4"

DOUBLE TUBE SHEET APPLICATION

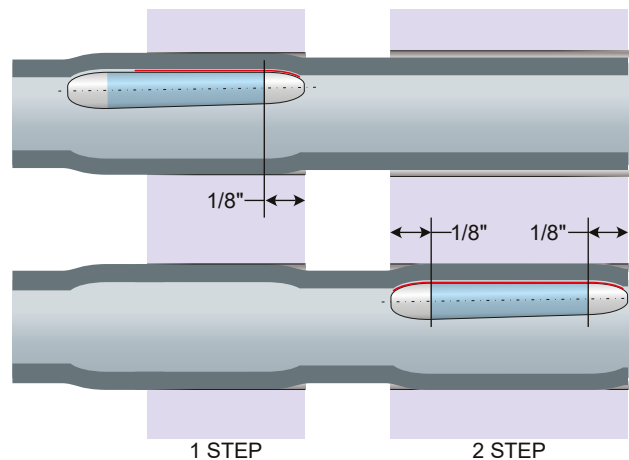

Primary tube sheet would be rolled with a 800 type expander with roll located per example.
Effective length of roll to be specified based on secondary tube sheet thickness. Secondary tube sheet would be rolled with a 1200 type expander with „2R" type rolls as per example. When rolling a secondary tube sheet always use „2R" type rolls. Position expander so that the roll straddles the tube sheet with the high points approx 1/8" inside front and sack of the tube sheet.



LUBE-A-TUBE FOR BETTER ROLLING

Special water soluble grease for rolling tube ends into tube sheets. Easy application: just apply directly to the inside of the tube ends; and easy removal: all Lube-A-Tube excess will be completely removed during any hydro test or boil-out operations.

- ▶ Lube-A-Tube is easy to apply. Stays in the tube during whole rolling operation - it will not leak.
- ▶ Lube-A-Tube does not carbonize under the heat and pressure found during the tube rolling operation.
- ▶ Lube-A-Tube keeps the expanding tool cool what gives a long tool life.
- ▶ Lube-A-Tube is effective for rolling condenser tubes, boiler tubes and others in many environments.
- ▶ Lube-A-Tube can be used as an "indicator" to show the operator what tubes are ready and what needs still to be expanded.



Condenser Tube Expanders

Typical thrust collars

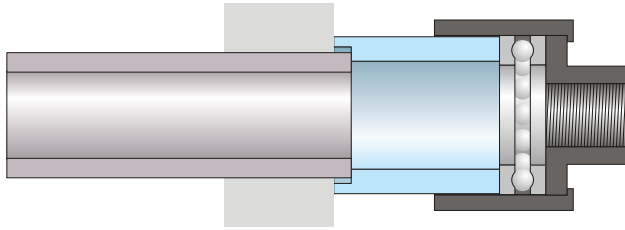

STC

Fixed recessed thrust collar 1/8". One flip type thrust collar for 1200&800 series tube expanders.

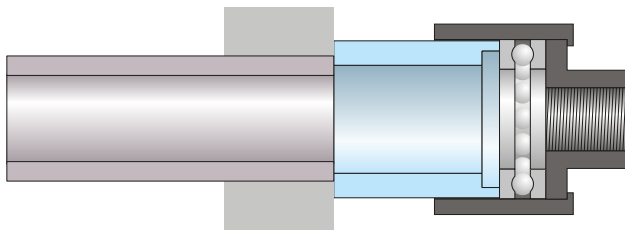

FRTC

Full recessed thrust collar.

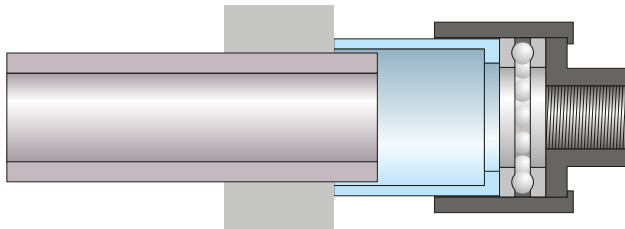

ARTC

Adjustable recess thrust collar 0,025 - 0,5".

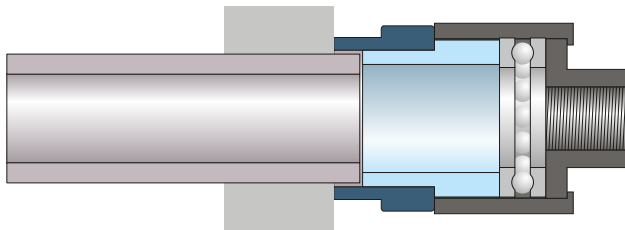

TWTC

Thin wall thrust collar.

Rolls for condenser expanders

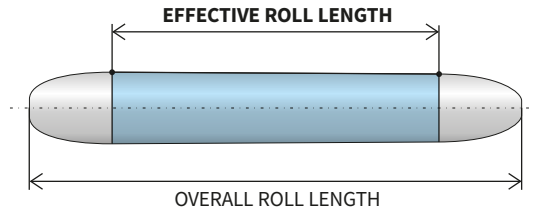

	38,1		57,1	
R-7	6,4 31,7 1/4" 1 1/4"	STD	6,4 50,7 1/4" 2"	R-7-A
R-7-2R	6,4 25,4 6,4 1/4" 1" 1/4"	2R	6,4 44,3 6,4 1/4" 1 3/4" 1/4"	R-7-A-2R
R-7-9R	9,5 19 9,5 3/8" 3/4" 3/8"	9R	9,5 38,1 9,5 3/8" 1 1/2" 3/8"	R-7-A-9R
R-7-3R	3,17 31,7 3,17 1/8" 1 1/4" 1/8"	3R	3,17 50,7 3,17 1/8" 2" 1/8"	R-7-A-3R
R-7-BLxx	6,4 xx 1/4" xx	BLxx	6,4 xx 1/4" xx	R-7-A-BLxx
R-7-2RBLxx	6,4 xx 6,4 1/4" xx 1/4"	2RBLxx	6,4 xx 1/4" xx	R-7-A-2RBLxx
R-7-3RBLxx	3,17 xx 3,17 1/8" xx 1/8"	3RBLxx	3,17 xx 3,17 1/8" xx 1/8"	R-7-A-3RBLxx

STANDARD

SPECIAL ORDER

900 Series

The KRAIS 900 series expanders cover very small tube diameters for fast, precise parallel rolling in typical heat transfer equipment. Use this series for small OD tubing to achieve consistent, cylindrical expansion in standard joints. They are ideal for HVAC, oil coolers, compact exchangers, and fine-tube condensers where precision is critical.



WORKING RANGE

TUBE ID	TUBE OD	TUBE SHEET
3,86 - 8,41 mm	6,35 - 9,50 MM	6,3 - 31,7 MM
0,152" - 0,331"	1/4" - 3/8"	1/4" to 1-1/4"

OPTIONAL SPARES AND ACCESSORIES



Available rolls
→ PAGE 11



Thrust collars
→ PAGE 10



Rolling motors
→ PAGE 45

TUBE OD		TUBE GAUGE		TUBE ID		EXPANSION RANGE				TUBE SHEET THICKNESS				MANDREL	MANDREL SQUARE		PNEUMATIC MOTOR *	ELECTRIC MOTOR *	
										1/4 TO 3/4"		3/4 TO 1-1/4"							
[INCH]	[MM]	[BWG]	[INCH]	[MM]	[INCH]	[MM]	MIN	MAX	MIN	MAX	TOOL NO.	ROLL NO.	TOOL NO.	ROLL NO.	[INCH]	[MM]			
1/4	6,35	18	0,049	1,24	0,152	3,86	0,151	0,173	3,84	4,39	921	921	-	-	M-39	1/4"	6,3	K20-2500	TES3000 S6000
		19	0,042	1,07	0,166	4,22	0,165	0,185	4,19	4,70	922	923	-	-	M-39	1/4"	6,3		
		20	0,035	0,89	0,180	4,57	0,175	0,200	4,45	5,08	923	923	-	-	M-40	1/4"	6,3		
		21	0,072	1,83	0,186	4,72	0,180	0,207	4,57	5,26	924	924	-	-	M-40	1/4"	6,3		
		22	0,028	0,71	0,194	4,93	0,190	0,216	4,83	5,49	925	925	-	-	M-41	1/4"	6,3		
		23	0,025	0,64	0,200	5,08	0,195	0,222	4,95	5,64	926	923	-	-	M-41	1/4"	6,3		
		24	0,022	0,56	0,206	5,23	0,201	0,230	5,11	5,84	927	924	-	-	M-41	1/4"	6,3		
		28	0,014	0,35	0,222	5,6	0,222	0,238	5,6	6,0	928	903	-	-	928	1/4"	6,3		
		29	0,013	0,33	0,224	5,7	0,222	0,238	5,6	6,0	928	903	-	-	928	1/4"	6,3		
		30	0,012	0,30	0,226	5,7	0,222	0,238	5,6	6,0	928	903	-	-	928	1/4"	6,3		
3/8	9,5	14	0,83	2,10	0,209	5,3	0,201	0,232	5,1	5,8	927	924	-	-	M-41	1/4"	6,3	K20-1800	TES3000 S3000
		15	0,072	1,83	0,231	5,87	0,230	0,265	5,84	6,73	915	903	-	-	M-42	1/4"	6,3		
		16	0,065	1,65	0,245	6,22	0,240	0,275	6,10	6,99	916	916	916L	916L	M-36	1/4"	6,3		
		17	0,058	1,47	0,259	6,58	0,255	0,289	6,48	7,34	918	903	920	904	M-38	1/4"	6,3		
		18	0,049	1,24	0,277	7,04	0,272	0,307	6,91	7,80	901	903	902	904	M-30	1/4"	6,3		
		19	0,042	1,07	0,291	7,39	0,286	0,320	7,26	8,13	903	903	904	904	M-31	1/4"	6,3		
		20	0,035	0,89	0,305	7,75	0,300	0,334	7,62	8,48	905	907	906	908	M-32	1/4"	6,3		
		21	0,032	0,81	0,311	7,90	0,306	0,340	7,77	8,64	907	907	908	908	M-33	1/4"	6,3		
		22	0,028	0,71	0,319	8,10	0,314	0,349	7,98	8,86	909	909	910	910	M-34	1/4"	6,3		
		23	0,025	0,64	0,325	8,26	0,320	0,357	8,13	9,07	911	911	912	912	M-34	1/4"	6,3		
24	0,022	0,56	0,331	8,41	0,319	0,357	8,10	9,07	911	911	912	912	M-34	1/4"	6,3				

* Motor recommendation applies only to most popular cases with a standard percentage of the wall reduction. The recommendation can be different for thicker tube sheet, harder and exotic metal tube and a higher percentage of wall reduction.

1300 Series

KRAIS 1300 series expanders are designed for small tubing where additional reach and a longer roll zone are required. This makes them a strong choice for thick tube sheets or deeper seating geometries. These tools are frequently used for small coolers, especially in service and retubing work where access and geometry drive the need for reach.



WORKING RANGE

TUBE ID	TUBE OD	TUBE SHEET
5,87 - 8,41 mm	9,5 MM	19,0 - 88,9 MM
0,231" - 0,331"	3/8"	3/4" to 3-1/2"

OPTIONAL SPARES AND ACCESSORIES



Available rolls
→ PAGE 11



Thrust collars
→ PAGE 10



Rolling motors
→ PAGE 45

TUBE OD		TUBE GAUGE		TUBE ID		EXPANSION RANGE				TUBE SHEET THICKNESS				MANDREL	MANDREL SQUARE		PNEUMATIC MOTOR	ELECTRIC MOTOR	
										3/4" TO 3"		1-1/4" TO 3-1/2"							
[INCH]	[MM]	[BWG]	[INCH]	[MM]	[INCH]	[MM]	MIN	MAX	MIN	MAX	TOOL NO.	ROLL NO.	TOOL NO.	ROLL NO.	[INCH]	[MM]			
3/8	9,5	15	0,072	1,83	0,231	5,87	0,230	0,265	5,84	6,73	1315	1315	1316	1316	M-86	1/4"	6,3	K20-1800	TES3000 S3000
		16	0,065	1,65	0,245	6,22	0,240	0,275	6,10	6,99	1319	1315	1319-L	916-L	M-86	1/4"	6,3		
		17	0,058	1,47	0,259	6,58	0,255	0,289	6,48	7,34	1317	903	1318	904	M-88	1/4"	6,3		
		18	0,049	1,24	0,277	7,04	0,272	0,307	6,91	7,80	1301	903	1302	904	M-80	1/4"	6,3		
		19	0,042	1,07	0,291	7,39	0,286	0,320	7,26	8,13	1303	903	1304	904	M-81	1/4"	6,3		
		20	0,035	0,89	0,305	7,75	0,300	0,334	7,62	8,48	1305	907	1306	908	M-82	1/4"	6,3		
		21	0,032	0,81	0,311	7,90	0,306	0,340	7,77	8,64	1307	907	1308	908	M-83	1/4"	6,3		
		22	0,028	0,71	0,319	8,10	0,314	0,349	7,98	8,86	1309	909	1310	910	M-84	1/4"	6,3		
		23	0,025	0,64	0,325	8,26	0,320	0,357	8,13	9,07	1311	911	1312	912	M-84	1/4"	6,3		
24	0,022	0,56	0,331	8,41	0,319	0,357	8,10	9,07	1311	911	1312	912	M-84	1/4"	6,3				

* Motor recommendation applies only to most popular cases with a standard percentage of the wall reduction. The recommendation can be different for thicker tube sheet, harder and exotic metal tube and a higher percentage of wall reduction.

800 Series

KRAIS 800 series expanders are the baseline, general-purpose family for the most common tube sizes in exchangers and condensers. Choose this series for typical diameters and standard tube sheet thicknesses. They deliver efficient, uniform rolling without special joint requirements, ensuring reliable performance across standard industrial tasks.



WORKING RANGE

TUBE ID	TUBE OD	TUBE SHEET
8,48 - 26,9 mm	12,7 - 38,1 MM	12,7 - 57,1 MM
0,334" - 1,027"	1/2" to 1-1/2"	1/2" to 2-1/4"

ADDITIONAL INFORMATION



How-to basics
→ PAGE 11



Rolls range
→ PAGE 10



Rolling motors
→ PAGE 45

TUBE OD		TUBE GAUGE		TUBE ID		EXPANSION RANGE				TUBE SHEET THICKNESS				MANDREL	MANDREL SQUARE		PNEUMATIC MOTOR *	ELECTRIC MOTOR *			
										1/2 TO 1-1/2"		1-1/4 TO 2-1/4"									
										12,7 TO 38,1 MM		31,7 TO 57,1 MM									
[INCH]	[MM]	[BWG]	[INCH]	[MM]	[INCH]	[MM]	MIN	MAX	MIN	MAX	TOOL NO.	ROLL NO.	TOOL NO.	ROLL NO.	[INCH]	[MM]					
3/8	9,5	22-24	0,027	0,71	0,314	8,00	0,307	0,358	7,80	9,10	795	795	-	-	797	3/8	9,5	K20-500	TES300 S1500 or TESMini2 HTO		
		14	0,083	2,11	0,334	8,48	0,324	0,374	8,23	9,50	797	797	-	-	797	3/8	9,5				
1/2	12,7	15	0,072	1,83	0,356	9,04	0,348	0,398	8,84	10,11	799	R-1	-	-	799	3/8	9,5	K20-1800			
		16	0,065	1,65	0,370	9,40	0,36	0,410	9,14	10,41	801	R-1	-	-	M-1	3/8	9,5				
		17	0,058	1,47	0,384	9,75	0,374	0,424	9,50	10,77	803	R-2	-	-	M-1	3/8	9,5				
		18	0,049	1,24	0,402	10,21	0,392	0,447	9,96	11,35	805	R-3	-	-	M-2	3/8	9,5				
		20	0,035	0,89	0,430	10,92	0,406	0,461	10,31	11,71	805[S]	R-3	-	-	M-3	3/8	9,5				
		12	0,109	2,77	0,407	10,34	0,392	0,447	9,96	11,35	805	R-3	-	-	M-2	3/8	9,5				
5/8	15,8	13	0,095	2,41	0,435	11,05	0,425	0,480	10,80	12,19	807	R-4	-	-	M-3	3/8	9,5	K50-600	TES3000 G1450 or TesMini2 ES2		
		14	0,083	2,11	0,459	11,66	0,449	0,509	11,40	12,93	809	R-4	810	R-4-A	M-4	3/8	9,5				
		15	0,072	1,83	0,481	12,22	0,471	0,536	11,96	13,61	811	R-5	812	R-5A	M-5	3/8	9,5				
		16	0,065	1,65	0,495	12,57	0,485	0,550	12,32	13,97	813	R-6	814	R-6A	M-5	3/8	9,5				
		17	0,058	1,47	0,509	12,93	0,499	0,564	12,67	14,33	815	R-6	816	R-6A	M-6	3/8	9,5				
		18	0,049	1,24	0,527	13,39	0,517	0,572	13,13	14,53	817	R-7	818	R-7-A	M-7 M-5	3/8	9,5				
		19	0,042	1,07	0,541	13,74	0,522	0,582	13,26	14,78	819	R-7	820	R-7-A	M-6	3/8	9,5				
		20	0,035	0,89	0,555	14,10	0,536	0,596	13,61	15,14	819[S]	R-7	820[S]	R-7-A	M-8	3/8	9,5				
3/4	19	21	0,032	0,81	0,561	14,25	0,536	0,596	13,61	15,14	819[S]	R-7	820[S]	R-7-A	M-8	3/8	9,5	K50-1250	TES3000 G1000 or TESMini2 DUO		
		22	0,028	0,71	0,569	14,45	0,536	0,596	13,61	15,14	819[S]	R-7	820[S]	R-7-A	M-8	3/8	9,5				
		10	0,134	3,40	0,482	12,24	0,471	0,536	11,96	13,61	811	R-5	812	R-5-A	M-5	3/8	9,5			K60-900	TES3000 + G1000 TESMini 2 +ES2
		11	0,120	3,05	0,510	12,95	0,499	0,564	12,67	14,33	815	R-6	816	R-6-A	M-6	3/8	9,5				
		12	0,109	2,77	0,532	13,51	0,522	0,582	13,26	14,78	819	R-7	820	R-7-A	M-6	3/8	9,5				
		13	0,095	2,41	0,560	14,22	0,550	0,615	13,97	15,62	821	R-8	822	R-8-A	M-8	3/8	9,5				
		14	0,083	2,11	0,584	14,83	0,574	0,639	14,58	16,23	823	R-9	824	R-9-A	M-8	3/8	9,5				
15	0,072	1,83	0,606	15,39	0,596	0,661	15,14	16,79	825	R-10	826	R-10-A	M-8	3/8	9,5						
16	0,065	1,65	0,620	15,75	0,605	0,685	15,37	17,40	827	R-10	828	R-10-A	M-9	3/8	9,5						

800 Series

TUBE OD		TUBE GAUGE			TUBE ID		EXPANSION RANGE				TUBE SHEET THICKNESS				MANDREL	MANDREL SQUARE		PNEUMATIC MOTOR *	ELECTRIC MOTOR *
											1/2 TO 1-1/2"		1-1/4 TO 2-1/4"						
							[INCH]	[MM]	[BVG]	[INCH]	[MM]	[INCH]	[MM]	MIN		MAX	MIN		
3/4	19	17	0,058	1,47	0,634	16,10	0,619	0,699	15,72	17,75	829	R-11	830	R-11-A	M-9	3/8	9,5	K50-1250	TES3000 G1000 or TESMini2 DUO
		18	0,049	1,24	0,652	16,56	0,619	0,699	15,72	17,75	829	R-11	830	R-11-A	M-9	3/8	9,5		
		19	0,042	1,07	0,666	16,92	0,642	0,722	16,31	18,34	831	R-12	832	R-12-A	M-9	3/8	9,5		
		20	0,035	0,89	0,680	17,27	0,642	0,722	16,31	18,34	831	R-12	832	R-12-A	M-9	3/8	9,5		
		21	0,032	0,81	0,686	17,42	0,642	0,722	16,31	18,34	831	R-12	832	R-12-A	M-9	3/8	9,5		
		22	0,028	0,71	0,694	17,63	0,642	0,722	16,31	18,34	831	R-12	832	R-12-A	M-9	3/8	9,5		
7/8	22,2	10	0,134	3,40	0,607	15,42	0,596	0,661	15,14	16,79	825	R-10	826	R-10-A	M-8	3/8	9,5	K50-400	TES3000 G1000 or TESMini2 ES2
		11	0,120	3,05	0,635	16,13	0,619	0,699	15,72	17,75	829	R-11	830	R-11-A	M-9	3/8	9,5		
		12	0,109	2,77	0,657	16,69	0,642	0,722	16,31	18,34	831	R-12	832	R-12-A	M-9	3/8	9,5		
		13	0,095	2,41	0,685	17,40	0,670	0,750	17,02	19,05	833	R-13	834	R-13-A	M-10	3/8	9,5		
		14	0,083	2,11	0,709	18,01	0,685	0,774	17,40	19,66	835	R-14	836	R-14-A	M-11	3/8	9,5	K50-600	
		15	0,072	1,83	0,731	18,57	0,712	0,801	18,08	20,35	837	R-15	838	R-15-A	M-11	3/8	9,5		
		16	0,065	1,65	0,745	18,92	0,726	0,815	18,44	20,70	839	R-15	840	R-15-A	M-12	3/8	9,5		
		17	0,058	1,47	0,759	19,28	0,740	0,829	18,80	21,06	843	R-16	844	R-16-A	M-12	3/8	9,5		
18	0,049	1,24	0,777	19,74	0,740	0,829	18,80	21,06	843	R-16	844	R-16-A	M-12	3/8	9,5	K50-1250	TES3000 G1450 or TESMini2 ES2		
1	25,4	8	0,165	4,19	0,670	17,02	0,655	0,735	16,64	18,67	841	R-13	842	R-13-A	M-9	3/8	9,5	K60-400	TES3000 G1000 or TESMini2 ES2
		9	0,148	3,76	0,704	17,88	0,685	0,774	17,40	19,66	835	R-14	836	R-14-A	M-11	3/8	9,5		
		10	0,134	3,40	0,732	18,59	0,712	0,801	18,08	20,35	837	R-15	838	R-15-A	M-11	3/8	9,5		
		11	0,120	3,05	0,760	19,30	0,740	0,829	18,80	21,06	843	R-16	844	R-16-A	M-12	3/8	9,5		
		12	0,109	2,77	0,782	19,86	0,763	0,852	19,38	21,64	845	R-17	846	R-17-A	M-12	3/8	9,5	K50-400	
		13	0,095	2,41	0,810	20,57	0,791	0,880	20,09	22,35	847	R-18	848	R-18-A	M-12	3/8	9,5		
		14	0,083	2,11	0,834	21,18	0,810	0,909	20,57	23,09	849	R-18	850	R-18-A	M-13	3/8	9,5		
		15	0,072	1,83	0,856	21,74	0,837	0,936	21,26	23,77	851	R-19	852	R-19-A	M-13	3/8	9,5		
		16	0,065	1,65	0,870	22,10	0,837	0,936	21,26	23,77	851	R-19	852	R-19-A	M-13	3/8	9,5	K50-600	
		17	0,058	1,47	0,884	22,45	0,865	0,964	21,97	24,49	855	R-21	856	R-21-A	M-13	3/8	9,5		
		18	0,049	1,24	0,902	22,91	0,865	0,964	21,97	24,49	855	R-21	856	R-21-A	M-13	3/8	9,5		
		19	0,042	1,07	0,916	23,27	0,865	0,964	21,97	24,49	855	R-21	856	R-21-A	M-13	3/8	9,5		
20	0,035	0,89	0,930	23,62	0,865	0,964	21,97	24,49	855	R-21	856	R-21-A	M-13	3/8	9,5				
1-1/8	28,5	8	0,165	4,19	0,795	20,19	0,776	0,875	19,71	22,23	853	R-20	854	R-20-A	M-13	3/8	9,5	K60-400	TES3000 G1000 or TESMini2 DU1
		9	0,148	3,76	0,829	21,06	0,810	0,909	20,57	23,09	849	R-18	850	R-18-A	M-13	3/8	9,5		
		10	0,134	3,40	0,857	21,77	0,837	0,936	21,26	23,77	851	R-19	852	R-19-A	M-13	3/8	9,5		
		11	0,120	3,05	0,885	22,48	0,865	0,964	21,97	24,49	855	R-21	856	R-21-A	M-13	3/8	9,5		
		12	0,109	2,77	0,907	23,04	0,883	0,982	22,43	24,94	857	R-21	858	R-21-A	M-14	1/2	12,7	K60-400	
		13	0,095	2,41	0,935	23,75	0,916	1,015	23,27	25,78	859	R-22	860	R-22-A	M-14	1/2	12,7		
		14	0,083	2,11	0,959	24,36	0,935	1,044	23,75	26,52	861	R-23	862	R-23-A	M-15	1/2	12,7		
		15	0,072	1,83	0,981	24,92	0,962	1,071	24,43	27,20	863	R-24	864	R-24-A	M-15	1/2	12,7		
		16	0,065	1,65	0,995	25,27	0,962	1,071	24,43	27,20	863	R-24	864	R-24-A	M-15	1/2	12,7		
		17	0,058	1,47	1,009	25,63	0,990	1,099	25,15	27,91	867	R-26	868	R-26-A	M-16	1/2	12,7		
18	0,049	1,24	1,027	26,09	0,990	1,099	25,15	27,91	867	R-26	868	R-26-A	M-16	1/2	12,7				
1-1/4	31,7	8	0,165	4,19	0,92	23,37	0,901	1,010	22,89	25,65	865	R-25	866	R-25-A	M-15	1/2	12,7	K60-400	TES3000 G1000 or TESMini2 DU1
		9	0,148	3,76	0,954	24,23	0,935	1,044	23,75	26,52	861	R-23	862	R-23-A	M-15	1/2	12,7		
		10	0,134	3,40	0,982	24,94	0,962	1,071	24,43	27,20	863	R-24	864	R-24-A	M-15	1/2	12,7		
		11	0,120	3,05	1,010	25,65	0,990	1,099	25,15	27,91	867	R-26	868	R-26-A	M-16	1/2	12,7		
		12	0,109	2,77	1,032	26,21	1,013	1,122	25,73	28,50	869	R-27	870	R-27-A	M-16	1/2	12,7	K60-400	
		13	0,095	2,41	1,060	26,92	1,041	1,150	26,44	29,21	871	R-28	872	R-28-A	M-17	1/2	12,7		
		14	0,083	2,11	1,084	27,53	1,060	1,169	26,92	29,69	873	R-29	874	R-29-A	M-17	1/2	12,7		
		15	0,072	1,83	1,106	28,09	1,087	1,196	27,61	30,38	875	R-30	876	R-30-A	M-17	1/2	12,7		
		16	0,065	1,65	1,12	28,45	1,087	1,196	27,61	30,38	875	R-30	876	R-30-A	M-17	1/2	12,7		
		17	0,058	1,47	1,134	28,80	1,115	1,224	28,32	31,09	879	R-30	880	R-30-A	M-18	1/2	12,7		
18	0,049	1,24	1,152	29,26	1,115	1,224	28,32	31,09	879	R-30	880	R-30-A	M-18	1/2	12,7				

800 Series

TUBE OD		TUBE GAUGE		TUBE ID		EXPANSION RANGE				TUBE SHEET THICKNESS				MANDREL	MANDREL SQUARE		PNEUMATIC MOTOR *	ELECTRIC MOTOR *	
										1/2 TO 1-1/2"		1-1/4 TO 2-1/4"							
[INCH]	[MM]	[BWG]	[INCH]	[MM]	[INCH]	[MM]	MIN	MAX	MIN	MAX	TOOL NO.	ROLL NO.	TOOL NO.	ROLL NO.	[INCH]	[MM]			
1-3/8	34,9	8	0,165	4,19	1,045	26,54	1,026	1,135	26,06	28,83	877	R-31	878	R-31-A	M-17	1/2	12,7	K60-250	TES3000 G400 or TESMini2 DU1
		9	0,148	3,76	1,079	27,41	1,060	1,169	26,92	29,69	873	R-29	874	R-29-A	M-17	1/2	12,7		
		10	0,134	3,40	1,107	28,12	1,087	1,196	27,61	30,38	875	R-30	876	R-30-A	M-17	1/2	12,7		
		11	0,120	3,05	1,135	28,83	1,115	1,224	28,32	31,09	879	R-30	880	R-30-A	M-18	1/2	12,7		
		12	0,109	2,77	1,157	29,39	1,133	1,242	28,78	31,55	881	R-32	882	R-32-A	M-18	1/2	12,7	K60-400	
		13	0,095	2,41	1,185	30,10	1,160	1,275	29,46	32,39	883	R-33	884	R-33-A	M-19	1/2	12,7		
		14	0,083	2,11	1,209	30,71	1,179	1,294	29,95	32,87	885	R-34	886	R-34-A	M-20	1/2	12,7		
		15	0,072	1,83	1,231	31,27	1,206	1,321	30,63	33,55	887	R-35	888	R-35-A	M-20	1/2	12,7		
		16	0,065	1,65	1,245	31,62	1,206	1,321	30,63	33,55	887	R-35	888	R-35-A	M-20	1/2	12,7		
1-1/2	38,1	8	0,165	4,19	1,170	29,72	1,145	1,260	29,08	32,00	889	R-34	890	R-34-A	M-19	1/2	12,7	K60-250	TES3000 G400 or TESMini2 DU1
		9	0,148	3,76	1,204	30,58	1,179	1,294	29,95	32,87	885	R-34	886	R-34-A	M-20	1/2	12,7		
		10	0,134	3,40	1,232	31,29	1,206	1,321	30,63	33,55	887	R-35	888	R-35-A	M-20	1/2	12,7		
		11	0,120	3,05	1,260	32,00	1,235	1,350	31,37	34,29	891	R-36	892	R-36-A	M-20	1/2	12,7		
		12	0,109	2,77	1,282	32,56	1,257	1,372	31,93	34,85	893	R-37	894	R-37-A	M-20	1/2	12,7	K60-400	
		13	0,095	2,41	1,310	33,27	1,285	1,400	32,64	35,56	895	R-37	896	R-37-A	M-21	1/2	12,7		
		14	0,083	2,11	1,334	33,88	1,285	1,400	32,64	35,56	895	R-37	896	R-37-A	M-21	1/2	12,7		
		15	0,072	1,83	1,356	34,44	1,331	1,446	33,81	36,73	897	R-38	898	R-38-A	M-21	1/2	12,7		
		16	0,065	1,65	1,370	34,80	1,331	1,446	33,81	36,73	897	R-38	898	R-38-A	M-21	1/2	12,7		
		17	0,058	1,47	1,384	35,15	1,331	1,472	33,81	37,39	899	R-38	900	R-38-A	M-22	1/2	12,7		
		18	0,049	1,24	1,402	35,61	1,331	1,472	33,81	37,39	899	R-38	900	R-38-A	M-22	1/2	12,7		
		19	0,042	1,07	1,416	35,97	1,331	1,472	33,81	37,39	899	R-38	900	R-38-A	M-22	1/2	12,7		
20	0,035	0,89	1,430	36,32	1,331	1,472	33,81	37,39	899	R-38	900	R-38-A	M-22	1/2	12,7				

* Motor recommendation applies only to most popular cases with a standard percentage of the wall reduction. The recommendation can be different for thicker tube sheet, harder and exotic metal tube and a higher percentage of wall reduction.

RECOMMENDATION

Recommended selection of thrust collars when rolling pipes from both sides to prevent the formation of stresses.

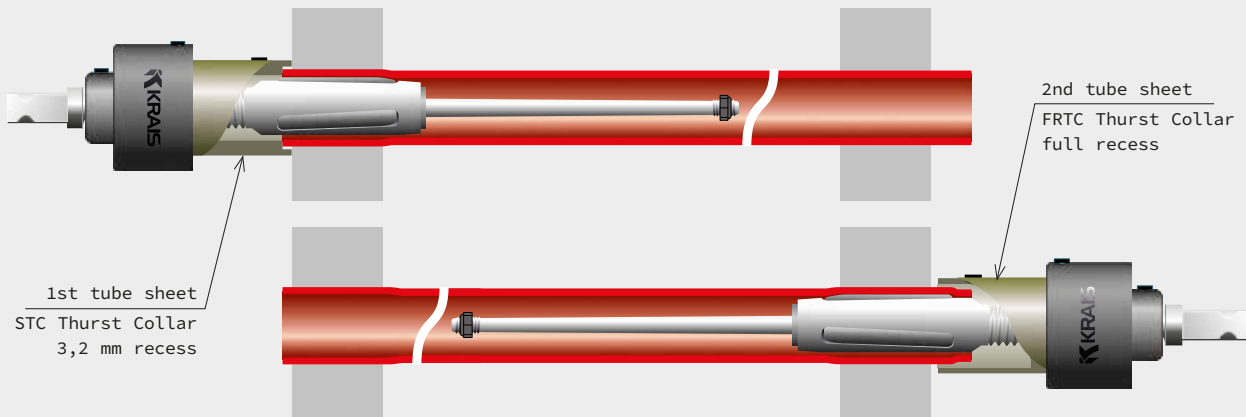

800-5 Five Roll Series

KRAIS 800-5 is a five-roll series designed for thin-wall tubes and materials sensitive to deformation. The five rolls distribute forming forces more evenly than standard tools, significantly reducing the risk of ovality and local distortion. This specialized design ensures joint integrity in very thin-wall tubing where precision is paramount.



WORKING RANGE

TUBE ID	TUBE OD	TUBE SHEET
12,98 - 36,68 MM	15,8 - 38,1 MM	12,7 - 57,1 MM
0,509" - 1,440"	5/8" to 1-1/2"	1/2" to 2-1/4"

ADDITIONAL INFORMATION



How-to basics
→ PAGE 11



Rolls range
→ PAGE 10



Rolling motors
→ PAGE 45

TUBE OD		TUBE GAUGE		TUBE ID		EXPANSION RANGE				TUBE SHEET THICKNESS				MANDREL	MANDREL SQUARE		PNEUMATIC MOTOR *	ELECTRIC MOTOR *	
										1/2" TO 1-1/2"		1-1/4" TO 2-1/4"							
[INCH]	[MM]	[BWG]	[INCH]	[MM]	[INCH]	[MM]	MIN	MAX	MIN	MAX	TOOL NO.	ROLL NO.	TOOL NO.	ROLL NO.	[INCH]	[MM]			
5/8	15,8	17	0,058	1,47	0,509	12,93	0,499	0,564	12,67	14,33	815-5	R-4-5	816-5	R-4-A-5	M-816-5	3/8	9,5	K50-1250	TES3000 G1000 or TESMini2 DUO
		18	0,049	1,24	0,527	13,39	0,517	0,572	13,13	14,53	817-5	R-4-5	818-5	R-4-A-5	M-9	3/8	9,5		
		19	0,042	1,07	0,541	13,74	0,522	0,582	13,26	14,78	819-5	R-4-5	820-5	R-4-A-5	M-820-5	3/8	9,5		
		20	0,035	0,89	0,555	14,10	0,536	0,596	13,61	15,14	819-5[S]	R-4-5	820-5[S]	R-4-A-5	820-5[S]	3/8	9,5		
		21	0,032	0,81	0,561	14,25	0,536	0,596	13,61	15,14	819-5[S]	R-4-5	820-5[S]	R-4-A-5	820-5[S]	3/8	9,5		
		22	0,028	0,71	0,569	14,45	0,536	0,596	13,61	15,14	819-5[S]	R-4-5	820-5[S]	R-4-A-5	820-5[S]	3/8	9,5		
3/4	19,0	13	0,095	2,41	0,560	14,22	0,550	0,615	13,97	15,62	821-5	R-5-5	822-5	R-5-A-5	M-822-5	3/8	9,5	K50-600	TES3000 + G1450 TesMini2 + ES2
		14	0,083	2,11	0,584	14,83	0,574	0,639	14,58	16,23	823-5	R-6-5	824-5	R-6-A-5	M-824-5	3/8	9,5		
		15	0,072	1,83	0,606	15,39	0,590	0,661	14,99	16,79	825-5	R-7-5	826-5	R-7-A-5	M-826-5	3/8	9,5		
		16	0,065	1,65	0,620	15,75	0,605	0,685	15,37	17,40	827-5	R-7-5	828-5	R-7-A-5	M-13	3/8	9,5		
		17	0,058	1,47	0,634	16,10	0,619	0,699	15,72	17,75	829-5	R-7-5	830-5	R-7-A-5	M-830-5	3/8	9,5		
		18	0,049	1,24	0,652	16,56	0,619	0,699	15,72	17,75	829-5	R-7-5	830-5	R-7-A-5	M-830-5	3/8	9,5		
		19	0,042	1,07	0,666	16,92	0,642	0,722	16,31	18,34	831-5	R-9-5	832-5	R-9-A-5	M-13	3/8	9,5		
		20	0,035	0,89	0,680	17,27	0,642	0,722	16,31	18,34	831-5	R-9-5	832-5	R-9-A-5	M-13	3/8	9,5		
		21	0,032	0,81	0,686	17,42	0,642	0,722	16,31	18,34	831-5	R-9-5	832-5	R-9-A-5	M-13	3/8	9,5		
		22	0,028	0,71	0,694	17,63	0,642	0,722	16,31	18,34	831-5	R-9-5	832-5	R-9-A-5	M-13	3/8	9,5		
7/8	22,2	13	0,095	2,41	0,685	17,40	0,670	0,750	17,02	19,05	833-5	R-9-5	834-5	R-9-A-5	M-14-3/8	3/8	9,5	K50-600	TES3000 G1450 or TESMini2 ES2
		14	0,083	2,11	0,709	18,01	0,685	0,774	17,40	19,66	835-5	R-10-5	836-5	R-10-A-5	M-15	3/8	9,5		
		16	0,065	1,65	0,745	18,92	0,726	0,815	18,44	20,70	839-5	R-11-5	840-5	R-11-A-5	M-840-5	3/8	9,5		
		17	0,058	1,47	0,759	19,28	0,740	0,829	18,80	21,06	843-5	R-11-5	844-5	R-11-A-5	M-17-3/8	3/8	9,5		
		18	0,049	1,24	0,777	19,74	0,740	0,829	18,80	21,06	843-5	R-11-5	844-5	R-11-A-5	M-17-3/8	3/8	9,5		
		19	0,042	1,07	0,791	20,09	0,763	0,852	19,38	21,64	845-5	R-11-5	846-5	R-11-A-5	M-18-3/8	3/8	9,5		
		20	0,035	0,89	0,805	20,45	0,763	0,852	19,38	21,64	845-5	R-11-5	846-5	R-11-A-5	M-18-3/8	3/8	9,5		
		21	0,032	0,81	0,811	20,60	0,763	0,852	19,38	21,64	845-5	R-11-5	846-5	R-11-A-5	M-18-3/8	3/8	9,5		
22	0,028	0,71	0,819	20,80	0,763	0,852	19,38	21,64	845-5	R-11-5	846-5	R-11-A-5	M-18-3/8	3/8	9,5				

800-5 Five Roll Series

TUBE OD		TUBE GAUGE		TUBE ID		EXPANSION RANGE				TUBE SHEET THICKNESS				MANDREL	MANDREL SQUARE		PNEUMATIC MOTOR *	ELECTRIC MOTOR *	
										1/2" TO 1-1/2"		1-1/4" TO 2-1/4"							
						[INCH]	[MM]	MIN	MAX	MIN	MAX	TOOL NO.	ROLL NO.		TOOL NO.	ROLL NO.			[INCH]
1	25,4	12	0,109	2,77	0,782	19,86	0,763	0,852	19,38	21,64	845-5	R-11-5	846-5	R-11-A-5	M-18-3/8	3/8	9,5	K50-600	TES3000 G1450 or TESMini2 ES2
		13	0,095	2,41	0,810	20,57	0,791	0,880	20,09	22,35	847-5	R-13-5	848-5	R-13-A-5	M-18-3/8	3/8	9,5		
		14	0,083	2,11	0,834	21,18	0,810	0,909	20,57	23,09	849-5	R-12-5	850-5	R-12-A-5	M-850-5	3/8	9,5		
		15	0,072	1,83	0,856	21,74	0,837	0,936	21,26	23,77	851-5	R-14-5	852-5	R-14-A-5	M-852-5	3/8	9,5		
		16	0,065	1,65	0,87	22,10	0,837	0,936	21,26	23,77	851-5	R-14-5	852-5	R-14-A-5	M-852-5	3/8	9,5		
		17	0,058	1,47	0,884	22,45	0,865	0,964	21,97	24,49	855-5	R-13-5	856-5	R-13-A-5	M-856-5	3/8	9,5	K50-1250	TES3000 G1000 or TESMini2 DU0
		18	0,049	1,24	0,902	22,91	0,865	0,964	21,97	24,49	855-5	R-13-5	856-5	R-13-A-5	M-856-5	3/8	9,5		
		19	0,042	1,07	0,916	23,27	0,865	0,964	21,97	24,49	855-5	R-13-5	856-5	R-13-A-5	M-856-5	3/8	9,5		
		20	0,035	0,89	0,93	23,62	0,865	0,964	21,97	24,49	855-5	R-13-5	856-5	R-13-A-5	M-856-5	3/8	9,5		
		21	0,032	0,81	0,936	23,77	0,883	0,982	22,43	24,94	857-5	R-15-5	858-5	R-15-A-5	M-21-3/8	3/8	9,5		
22	0,028	0,71	0,944	23,98	0,883	0,982	22,43	24,94	857-5	R-15-5	858-5	R-15-A-5	M-21-3/8	3/8	9,5	K60-400	TES3000 + G1000 TESMini2 + DU1		
12	0,109	2,77	0,907	23,04	0,883	0,982	22,43	24,94	857-5	R-15-5	858-5	R-15-A-5	M-21-3/8	3/8	9,5				
13	0,095	2,41	0,935	23,75	0,916	1,015	23,27	25,78	859-5	R-16-5	860-5	R-16-A-5	M-860-5	1/2	12,7				
14	0,083	2,11	0,959	24,36	0,935	1,044	23,75	26,52	861-5	R-17-5	862-5	R-17-A-5	M-862-5	1/2	12,7	K60-400	TES3000 G1000 or TESMini2 DU1		
15	0,072	1,83	1,106	28,09	1,087	1,196	27,61	30,38	875-5	R-21-5	876-5	R-21-A-5	M-876-5	1/2	12,7				
16	0,065	1,65	1,120	28,45	1,087	1,196	27,61	30,38	875-5	R-21-5	876-5	R-21-A-5	M-876-5	1/2	12,7				
17	0,058	1,47	1,134	28,80	1,115	1,231	28,32	31,27	879-5	R-21-5	880-5	R-21-A-5	M-880-5	1/2	12,7				
18	0,049	1,24	1,152	29,26	1,115	1,231	28,32	31,27	879-5	R-21-5	880-5	R-21-A-5	M-880-5	1/2	12,7				
19	0,042	1,07	1,166	29,62	1,115	1,231	28,32	31,27	879-5	R-21-5	880-5	R-21-A-5	M-880-5	1/2	12,7				
20	0,035	0,89	1,180	29,97	1,115	1,231	28,32	31,27	879-5	R-21-5	880-5	R-21-A-5	M-880-5	1/2	12,7				
21	0,032	0,81	1,186	30,12	1,115	1,231	28,32	31,27	879-5	R-21-5	880-5	R-21-A-5	M-880-5	1/2	12,7	K60-250			
22	0,028	0,71	1,194	30,33	1,115	1,231	28,32	31,27	879-5	R-21-5	880-5	R-21-A-5	M-880-5	1/2	12,7				
12	0,109	2,77	1,157	29,39	1,133	1,242	28,78	31,55	881-5	R-21-5	882-5	R-21-A-5	M-882-5	1/2	12,7	K60-900	TES3000 G1000 or TESMini2 ES2		
14	0,083	2,11	1,209	30,71	1,179	1,294	29,95	32,87	885-5	R-23-5	886-5	R-23-A-5	M-882-5	1/2	12,7				
17	0,058	1,47	1,384	35,15	1,331	1,472	33,81	37,39	899-5	R-29-5	900-5	R-29-A-5	M-900-5	1/2	12,7	K60-900	TES3000 G1000 or TESMini2 ES2		
18	0,049	1,24	1,402	35,61	1,331	1,472	33,81	37,39	899-5	R-29-5	900-5	R-29-A-5	M-900-5	1/2	12,7				
19	0,042	1,07	1,416	35,97	1,331	1,472	33,81	37,39	899-5	R-29-5	900-5	R-29-A-5	M-900-5	1/2	12,7				
20	0,035	0,89	1,430	36,32	1,331	1,472	33,81	37,39	899-5	R-29-5	900-5	R-29-A-5	M-900-5	1/2	12,7				
21	0,032	0,81	1,436	36,47	1,331	1,472	33,81	37,39	899-5	R-29-5	900-5	R-29-A-5	M-900-5	1/2	12,7				
22	0,028	0,71	1,444	36,68	1,331	1,472	33,81	37,39	899-5	R-29-5	900-5	R-29-A-5	M-900-5	1/2	12,7				

* Motor recommendation applies only to most popular cases with a standard percentage of the wall reduction. The recommendation can be different for thicker tube sheet, harder and exotic metal tube and a higher percentage of wall reduction.

RECOMMENDATION

For the thin wall tube, it is recommended to use 5 roll expanders with bottle rolls (BL) type rolls and BL type thrust collar to prevent the tube to be retracted inside the thrust collar making the tube projection uneven or even effectively jammed the tube inside collar.

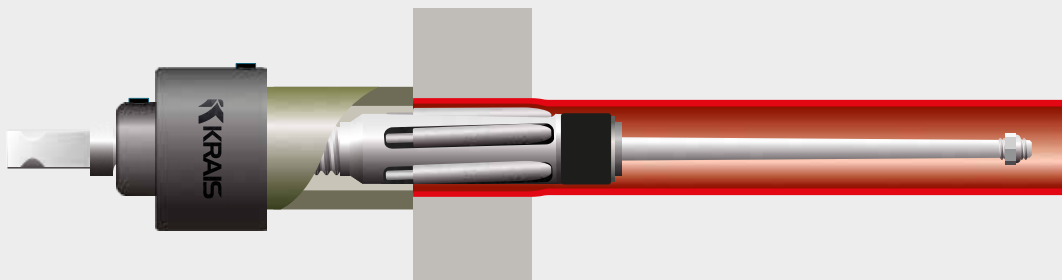

1200 Series

KRAIS 1200 series expanders address mainstream diameters but are engineered for thick tube sheets where standard reach is inadequate. Reach variants are selected to match specific tube sheet thickness, ensuring the cage length and tooling geometry define the effective roll zone perfectly. This ensures repeatable, high-quality expanded joints.



WORKING RANGE

TUBE ID	TUBE OD	TUBE SHEET
8,48 - 36,32 MM	12,7 - 38,1 MM	See table below
0,334 - 1,430"	1/2" to 1-1/2"	

ADDITIONAL INFORMATION



How-to basics
→ PAGE 11



Rolls range
→ PAGE 10



Rolling motors
→ PAGE 45

TUBE SHEET THICKNESS

ROLLS	REACH	TUBE SHEET THICKNESS	
		[INCH]	[MM]
1 1/2" 38,1	STD	1 1/2 - 6"	38,1 - 152,4 mm
	A	1 1/2 - 8"	38,1 - 203,2 mm
	B	1 1/2 - 10"	38,1 - 254,0 mm
	C	1 1/2 - 12"	38,1 - 304,8 mm
2 1/4" 57,1	STD	2 1/4 - 6 3/4"	57,1 - 171,4 mm
	A	2 1/4 - 8 3/4"	57,1 - 222,2 mm
	B	2 1/4 - 10 3/4"	57,1 - 273,0 mm
	C	2 1/4 - 12 3/4"	57,1 - 323,8 mm

NOTE!

Please note that expanders are equipped with "UNIVERSAL NOSE PIECE" which shorten the expansion reach by 3/4". In order to receive full expansion reach, expander has to be equipped with "SHORT NOSE PIECE".

OPTIONAL

Special extended thrust collars to reach the face of the tube sheet

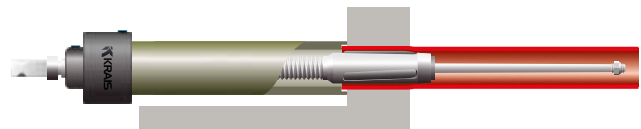

TUBE OD		TUBE GAUGE		TUBE ID		EXPANSION RANGE				TUBE SHEET THICKNESS				MANDREL	MANDREL SQUARE		PNEUMATIC MOTOR *	ELECTRIC MOTOR *			
										1/2" TO 6"		2-1/4" TO 6-3/4"									
[INCH]	[MM]	[BWG]	[INCH]	[MM]	[INCH]	[MM]	MIN	MAX	MIN	MAX	TOOL NO.	ROLL NO.	TOOL NO.	ROLL NO.	[INCH]	[MM]					
3/8	9,5	22-24	0,027	0,71	0,314	8,00	0,307	0,358	7,80	9,10	1195	795	-	-	M-1195	3/8	9,5	K20-500	TES300 S1500 or TESMini2 HTO		
1/2	12,7	14	0,083	2,11	0,334	8,48	0,324	0,374	8,23	9,50	1197	797	-	-	1197	3/8	9,5				
		15	0,072	1,83	0,356	9,04	0,348	0,398	8,84	10,11	1199	R-1	-	-	1199	3/8	9,5				
		16	0,065	1,65	0,370	9,40	0,36	0,41	9,14	10,41	1201	R-1	-	-	M-51	3/8	9,5				
		17	0,058	1,47	0,384	9,75	0,374	0,424	9,50	10,77	1203	R-2	-	-	M-51	3/8	9,5				
		18	0,049	1,24	0,402	10,21	0,392	0,447	9,96	11,35	1205	R-3	-	-	M-52	3/8	9,5				
5/8	15,8	20	0,035	0,89	0,430	10,92	0,406	0,461	10,31	11,71	1205[S]	R-3	-	-	M-53	3/8	9,5			K50-600	TES3000 G1450 or TesMini2 ES2
		12	0,109	2,77	0,407	10,34	0,392	0,447	9,96	11,35	1205	R-3	-	-	M-52	3/8	9,5				
		13	0,095	2,41	0,435	11,05	0,425	0,480	10,80	12,19	1207	R-4	-	-	M-53	3/8	9,5				
		14	0,083	2,11	0,459	11,66	0,449	0,509	11,40	12,93	1209	R-4	1210	R-4-A	M-54	3/8	9,5				
		15	0,072	1,83	0,481	12,22	0,471	0,536	11,96	13,61	1211	R-5	1212	R-5-A	M-55	3/8	9,5				

1200 Series

TUBE OD		TUBE GAUGE			TUBE ID		EXPANSION RANGE				TUBE SHEET THICKNESS				MANDREL	MANDREL SQUARE		PNEUMATIC MOTOR *	ELECTRIC MOTOR *		
											1/2" TO 6"		2-1/4" TO 6-3/4"								
											[INCH]	[MM]	[BVG]	[INCH]		[MM]	[INCH]			[MM]	MIN
5/8	15,8	16	0,065	1,65	0,495	12,57	0,485	0,550	12,32	13,97	1213	R-6	1214	R-6-A	M-55	3/8	9,5	K50-1250	TES3000 G1000 or TESMini2 DUO		
		17	0,058	1,47	0,509	12,93	0,499	0,564	12,67	14,33	1215	R-6	1216	R-6-A	M-56	3/8	9,5				
		18	0,049	1,24	0,527	13,39	0,517	0,572	13,13	14,53	1217	R-7	1218	R-7-A	M-58 M-55	3/8	9,5				
		19	0,042	1,07	0,541	13,74	0,522	0,582	13,26	14,78	1219	R-7	1220	R-7-A	M-56	3/8	9,5				
		20	0,035	0,89	0,555	14,10	0,536	0,596	13,61	15,14	1219[S]	R-7	1220[S]	R-7-A	M-58	3/8	9,5				
		21	0,032	0,81	0,561	14,25	0,536	0,596	13,61	15,14	1219[S]	R-7	1220[S]	R-7-A	M-58	3/8	9,5				
		22	0,028	0,71	0,569	14,45	0,536	0,596	13,61	15,14	1219[S]	R-7	1220[S]	R-7-A	M-58	3/8	9,5				
3/4	19	10	0,134	3,40	0,482	12,24	0,471	0,536	11,96	13,61	1211	R-5	1212	R-5-A	M-55	3/8	9,5	K60-900	TES3000 + G1000 TESMini2 + ES2		
		11	0,120	3,05	0,510	12,95	0,499	0,564	12,67	14,33	1215	R-6	1216	R-6-A	M-56	3/8	9,5				
		12	0,109	2,77	0,532	13,51	0,522	0,582	13,26	14,78	1219	R-7	1220	R-7-A	M-56	3/8	9,5				
		7/8	22,2	13	0,095	2,41	0,560	14,22	0,55	0,615	13,97	15,62	1221	R-8	1222	R-8-A	M-58	3/8	9,5	K50-400	TES3000 G1450 or TESMini2 ES2
				14	0,083	2,11	0,584	14,83	0,574	0,639	14,58	16,23	1223	R-9	1224	R-9-A	M-58	3/8	9,5		
				15	0,072	1,83	0,606	15,39	0,596	0,661	15,14	16,79	1225	R-10	1226	R-10-A	M-58	3/8	9,5	K50-600	TES3000 G1000 or TESMini2 DUO
				16	0,065	1,65	0,620	15,75	0,605	0,685	15,37	17,40	1227	R-10	1228	R-10-A	M-59	3/8	9,5		
				17	0,058	1,47	0,634	16,10	0,619	0,699	15,72	17,75	1229	R-11	1230	R-11-A	M-59	3/8	9,5		
				18	0,049	1,24	0,652	16,56	0,619	0,699	15,72	17,75	1229	R-11	1230	R-11-A	M-59	3/8	9,5		
				19	0,042	1,07	0,666	16,92	0,642	0,722	16,31	18,34	1231	R-12	1232	R-12-A	M-59	3/8	9,5		
				20	0,035	0,89	0,680	17,27	0,642	0,722	16,31	18,34	1231	R-12	1232	R-12-A	M-59	3/8	9,5		
				21	0,032	0,81	0,686	17,42	0,642	0,722	16,31	18,34	1231	R-12	1232	R-12-A	M-59	3/8	9,5		
22	0,028	0,71	0,694	17,63	0,642	0,722	16,31	18,34	1231	R-12	1232	R-12-A	M-59	3/8	9,5						
7/8	22,2	10	0,134	3,40	0,607	15,42	0,596	0,661	15,14	16,79	1225	R-10	1226	R-10-A	M-58	3/8	9,5	K50-400	TES3000 G1000 or TESMini2 ES2		
		11	0,120	3,05	0,635	16,13	0,619	0,699	15,72	17,75	1229	R-11	1230	R-11-A	M-59	3/8	9,5				
		12	0,109	2,77	0,657	16,69	0,642	0,722	16,31	18,34	1231	R-12	1232	R-12-A	M-59	3/8	9,5				
		13	0,095	2,41	0,685	17,40	0,67	0,750	17,02	19,05	1233	R-13	1234	R-13-A	M-60	3/8	9,5	K50-600	TES3000 G1000 or TESMini2 ES2		
		14	0,083	2,11	0,709	18,01	0,685	0,774	17,40	19,66	1235	R-14	1236	R-14-A	M-61	3/8	9,5				
		15	0,072	1,83	0,731	18,57	0,712	0,801	18,08	20,35	1237	R-15	1238	R-15-A	M-61	3/8	9,5				
		16	0,065	1,65	0,745	18,92	0,726	0,815	18,44	20,70	1239	R-15	1240	R-15-A	M-62	3/8	9,5				
		17	0,058	1,47	0,759	19,28	0,740	0,829	18,80	21,06	1243	R-16	1244	R-16-A	M-62	3/8	9,5	K50-1250	TES3000 + G1450 TESMini2 ES2		
18	0,049	1,24	0,777	19,74	0,740	0,829	18,80	21,06	1243	R-16	1244	R-16-A	M-62	3/8	9,5						
1	25,4	8	0,165	4,19	0,670	17,02	0,655	0,735	16,64	18,67	1241	R-13	1242	R-13-A	M-59	3/8	9,5	K60-400	TES3000 G1000 or TESMini2 ES2		
		9	0,148	3,76	0,704	17,88	0,685	0,774	17,40	19,66	1235	R-14	1236	R-14-A	M-61	3/8	9,5				
		10	0,134	3,40	0,732	18,59	0,712	0,801	18,08	20,35	1237	R-15	1238	R-15-A	M-61	3/8	9,5				
		7/8	22,2	11	0,120	3,05	0,760	19,30	0,740	0,829	18,80	21,06	1243	R-16	1244	R-16-A	M-62	3/8	9,5	K50-400	TES3000 G1000 or TESMini2 ES2
				12	0,109	2,77	0,782	19,86	0,763	0,852	19,38	21,64	1245	R-17	1246	R-17-A	M-62	3/8	9,5		
				13	0,095	2,41	0,810	20,57	0,791	0,880	20,09	22,35	1247	R-18	1248	R-18-A	M-62	3/8	9,5		
				14	0,083	2,11	0,834	21,18	0,810	0,909	20,57	23,09	1249	R-18	1250	R-18-A	M-63	3/8	9,5		
				15	0,072	1,83	0,856	21,74	0,837	0,936	21,26	23,77	1251	R-19	1252	R-19-A	M-63	3/8	9,5		
				16	0,065	1,65	0,880	22,10	0,837	0,936	21,26	23,77	1251	R-19	1252	R-19-A	M-63	3/8	9,5		
				17	0,058	1,47	0,884	22,45	0,865	0,964	21,97	24,49	1255	R-21	1256	R-21-A	M-63	3/8	9,5	K50-600	TES3000 G1000 or TESMini2 DU1
				18	0,049	1,24	0,902	22,91	0,865	0,964	21,97	24,49	1255	R-21	1256	R-21-A	M-63	3/8	9,5		
19	0,042	1,07	0,916	23,27	0,865	0,964	21,97	24,49	1255	R-21	1256	R-21-A	M-63	3/8	9,5						
1-1/8	28,5	8	0,165	4,19	0,795	20,19	0,776	0,875	19,71	22,23	1253	R-20	1254	R-20-A	M-63	3/8	9,5	K60-400	TES3000 G1000 or TESMini2 DU1		
		9	0,148	3,76	0,829	21,06	0,810	0,909	20,57	23,09	1249	R-18	1250	R-18-A	M-63	3/8	9,5				
		10	0,134	3,40	0,857	21,77	0,837	0,936	21,26	23,77	1251	R-19	1252	R-19-A	M-63	3/8	9,5				
		11	0,120	3,05	0,885	22,48	0,865	0,964	21,97	24,49	1255	R-21	1256	R-21-A	M-63	3/8	9,5				
		12	0,109	2,77	0,907	23,04	0,883	0,982	22,43	24,94	1257	R-21	1258	R-21-A	M-64	1/2	12,7				
		13	0,095	2,41	0,935	23,75	0,916	1,015	23,27	25,78	1259	R-22	1260	R-22-A	M-64	1/2	12,7				
		14	0,083	2,11	0,959	24,36	0,935	1,044	23,75	26,52	1261	R-23	1262	R-23-A	M-65	1/2	12,7				
		15	0,072	1,83	0,981	24,92	0,962	1,071	24,43	27,20	1263	R-24	1264	R-24-A	M-65	1/2	12,7				
		16	0,065	1,65	0,995	25,27	0,962	1,071	24,43	27,20	1263	R-24	1264	R-24-A	M-65	1/2	12,7				
		17	0,058	1,47	1,009	25,63	0,990	1,099	25,15	27,91	1267	R-26	1268	R-26-A	M-66	1/2	12,7				
18	0,049	1,24	1,027	26,09	0,990	1,099	25,15	27,91	1267	R-26	1268	R-26-A	M-66	1/2	12,7						

1200 Series

TUBE OD		TUBE GAUGE			TUBE ID		EXPANSION RANGE				TUBE SHEET THICKNESS				MANDREL	MANDREL SQUARE		PNEUMATIC MOTOR *	ELECTRIC MOTOR *
											1/2" TO 6"		2-1/4" TO 6-3/4"						
[INCH]	[MM]	[BWG]	[INCH]	[MM]	[INCH]	[MM]	MIN	MAX	MIN	MAX	TOOL NO.	ROLL NO.	TOOL NO.	ROLL NO.	[INCH]	[MM]			
1-1/4	31,7	8	0,165	4,19	0,92	23,37	0,901	1,010	22,89	25,65	1265	R-25	1266	R-25-A	M-65	1/2	12,7	K60-400	TES3000 G1000 or TESMini2 DU1
		9	0,148	3,76	0,954	24,23	0,935	1,044	23,75	26,52	1261	R-23	1262	R-23-A	M-65	1/2	12,7		
		10	0,134	3,40	0,982	24,94	0,962	1,071	24,43	27,20	1263	R-24	1264	R-24-A	M-65	1/2	12,7		
		11	0,120	3,05	1,010	25,65	0,990	1,099	25,15	27,91	1267	R-26	1268	R-26-A	M-66	1/2	12,7		
		12	0,109	2,77	1,032	26,21	1,013	1,122	25,73	28,50	1269	R-27	1270	R-27-A	M-66	1/2	12,7		
		13	0,095	2,41	1,060	26,92	1,041	1,150	26,44	29,21	1271	R-28	1272	R-28-A	M-67	1/2	12,7		
		14	0,083	2,11	1,084	27,53	1,060	1,169	26,92	29,69	1273	R-29	1274	R-29-A	M-67	1/2	12,7		
		15	0,072	1,83	1,106	28,09	1,087	1,196	27,61	30,38	1275	R-30	1276	R-30-A	M-67	1/2	12,7		
		16	0,065	1,65	1,12	28,45	1,087	1,196	27,61	30,38	1275	R-30	1276	R-30-A	M-67	1/2	12,7		
1-3/8	34,9	8	0,165	4,19	1,045	26,54	1,026	1,135	26,06	28,83	1277	R-31	1278	R-31-A	M-67	1/2	12,7	K60-250	TES3000 G400 or TESMini2 DU1
		9	0,148	3,76	1,079	27,41	1,060	1,169	26,92	29,69	1273	R-29	1274	R-29-A	M-67	1/2	12,7		
		10	0,134	3,40	1,107	28,12	1,087	1,196	27,61	30,38	1275	R-30	1276	R-30-A	M-67	1/2	12,7		
		11	0,120	3,05	1,135	28,83	1,115	1,224	28,32	31,09	1279	R-30	1280	R-30-A	M-68	1/2	12,7		
		12	0,109	2,77	1,157	29,39	1,133	1,242	28,78	31,55	1281	R-32	1282	R-32-A	M-68	1/2	12,7		
		13	0,095	2,41	1,185	30,10	1,160	1,275	29,46	32,39	1283	R-33	1284	R-33-A	M-69	1/2	12,7		
		14	0,083	2,11	1,209	30,71	1,179	1,294	29,95	32,87	1285	R-34	1286	R-34-A	M-70	1/2	12,7		
		15	0,072	1,83	1,231	31,27	1,206	1,321	30,63	33,55	1287	R-35	1288	R-35-A	M-70	1/2	12,7		
		16	0,065	1,65	1,245	31,62	1,206	1,321	30,63	33,55	1287	R-35	1288	R-35-A	M-70	1/2	12,7		
1-1/2	38,1	8	0,165	4,19	1,170	29,72	1,145	1,260	29,08	32,00	1289	R-34	1290	R-34-A	M-69	1/2	12,7	K60-250	TES3000 G400 or TESMini2 DU1
		9	0,148	3,76	1,204	30,58	1,145	1,294	29,08	32,87	1285	R-34	1286	R-34-A	M-70	1/2	12,7		
		10	0,134	3,40	1,232	31,29	1,206	1,321	30,63	33,55	1287	R-35	1288	R-35-A	M-70	1/2	12,7		
		11	0,120	3,05	1,260	32,00	1,235	1,350	31,37	34,29	1291	R-36	1292	R-36-A	M-70	1/2	12,7		
		12	0,109	2,77	1,282	32,56	1,257	1,372	31,93	34,85	1293	R-37	1294	R-37-A	M-70	1/2	12,7		
		13	0,095	2,41	1,310	33,27	1,285	1,400	32,64	35,56	1295	R-37	1296	R-37-A	M-71	1/2	12,7		
		14	0,083	2,11	1,334	33,88	1,285	1,400	32,64	35,56	1295	R-37	1296	R-37-A	M-71	1/2	12,7		
		15	0,072	1,83	1,356	34,44	1,331	1,446	33,81	36,73	1297	R-38	1298	R-38-A	M-71	1/2	12,7		
		16	0,065	1,65	1,370	34,80	1,331	1,446	33,81	36,73	1297	R-38	1298	R-38-A	M-71	1/2	12,7		
		17	0,058	1,47	1,384	35,15	1,331	1,472	33,81	37,39	1299	R-38	1300	R-38-A	M-72	1/2	12,7		
		18	0,049	1,24	1,402	35,61	1,331	1,472	33,81	37,39	1299	R-38	1300	R-38-A	M-72	1/2	12,7		
19	0,042	1,07	1,416	35,97	1,331	1,472	33,81	37,39	1299	R-38	1300	R-38-A	M-72	1/2	12,7				
20	0,035	0,89	1,430	36,32	1,331	1,472	33,81	37,39	1299	R-38	1300	R-38-A	M-72	1/2	12,7				

* Motor recommendation applies only to most popular cases with a standard percentage of the wall reduction. The recommendation can be different for thicker tube sheet, harder and exotic metal tube and a higher percentage of wall reduction.

RECOMMENDATION

Recommended order of step by step expanding in a thick tube sheets in order to avoid tension between both tube sheets after rolling.

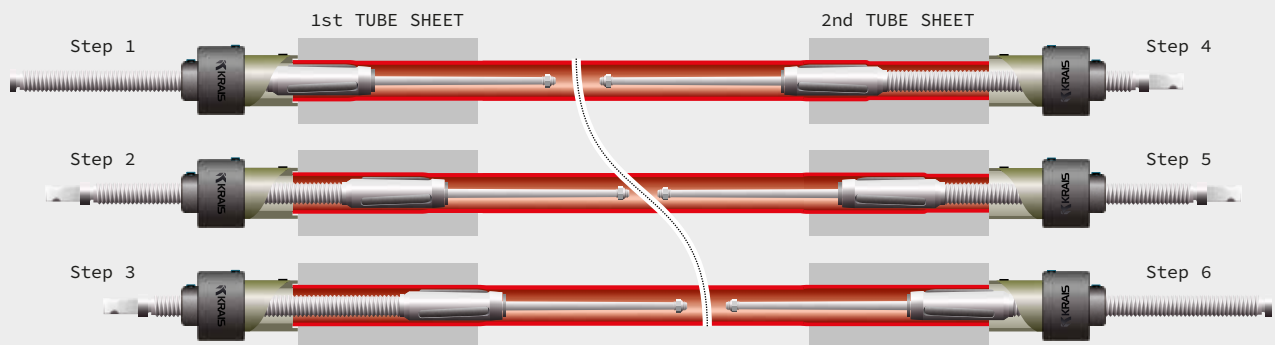

1200-5 Five Roll Series

KRAIS 1200-5 five-roll series expanders combine extended reach with a five-roll forming profile. Select this tool when the tube sheet is thick and the tube material or wall thickness requires gentler, more controlled expansion. It provides the reach of the 1200 series with the superior force distribution of a five-roll cage for sensitive tubes.



WORKING RANGE

TUBE ID	TUBE OD	TUBE SHEET
14,83 - 36,32 MM	19,0 - 38,1 MM	See table below
0,584 - 1,430"	1/2" to 1-1/2"	

TUBE SHEET THICKNESS

ROLLS	REACH	TUBE SHEET THICKNESS	
		[INCH]	[MM]
1-1/2" 38,1	STD	1 1/2 - 6"	38,1 - 152,4 mm
	A	1 1/2 - 8"	38,1 - 203,2 mm
	B	1 1/2 - 10"	38,1 - 254,0 mm
	C	1 1/2 - 12"	38,1 - 304,8 mm
2-1/4" 57,1	STD	2 1/4 - 6 3/4"	57,1 - 171,4 mm
	A	2 1/4 - 8 3/4"	57,1 - 222,2 mm
	B	2 1/4 - 10 3/4"	57,1 - 273,0 mm
	C	2 1/4 - 12 3/4"	57,1 - 323,8 mm

ADDITIONAL INFORMATION



How-to basics
→ PAGE 11



Rolls range
→ PAGE 10



Rolling motors
→ PAGE 45

NOTE! Please note that expanders are equipped with "UNIVERSAL NOSE PIECE" which shorten the expansion reach by 3/4". In order to receive full expansion reach, expander has to be equipped with "SHORT NOSE PIECE".

TUBE OD		TUBE GAUGE		TUBE ID		EXPANSION RANGE				TUBE SHEET THICKNESS				MANDREL SQUARE		PNEUMATIC MOTOR *	ELECTRIC MOTOR *		
										1/2" TO 6"		2-1/4" TO 6-3/4"							
[INCH]	[MM]	[BWG]	[INCH]	[MM]	[INCH]	[MM]	MIN	MAX	MIN	MAX	TOOL NO.	ROLL NO.	TOOL NO.	ROLL NO.	[INCH]	[MM]			
5/8	15,8	17	0,058	1,47	0,509	12,93	0,499	0,564	12,67	14,33	1215-5	R-4-5	1216-5	R-4-A-5	M-1216-5	3/8	9,5	K50-1250	TES3000 G1000 or TESMini2 DUO
		18	0,049	1,24	0,527	13,39	0,517	0,572	13,13	14,53	1217-5	R-4-5	1218-5	R-4-A-5	M-59	3/8	9,5		
		19	0,042	1,07	0,541	13,74	0,522	0,582	13,26	14,78	1219-5	R-4-5	1220-5	R-4-A-5	M-1220-5	3/8	9,5		
		20	0,035	0,89	0,555	14,10	0,536	0,596	13,61	15,14	1219-5[S]	R-4-5	1220-5[S]	R-4-A-5	M-1220-5[S]	3/8	9,5		
		21	0,032	0,81	0,561	14,25	0,536	0,596	13,61	15,14	1219-5[S]	R-4-5	1220-5[S]	R-4-A-5	M-1220-5[S]	3/8	9,5		
		22	0,028	0,71	0,569	14,45	0,536	0,596	13,61	15,14	1219-5[S]	R-4-5	1220-5[S]	R-4-A-5	M-1220-5[S]	3/8	9,5		
3/4	19,0	13	0,095	2,41	0,560	14,22	0,550	0,615	13,97	15,62	1221-5	R-5-5	1222-5	R-5-A-5	M-1222-5	3/8	9,5	K50-600	TES3000 G1450 TesMini2 ES2
		14	0,083	2,11	0,584	14,83	0,574	0,639	14,58	16,23	1223-5	R-6-5	1224-5	R-6-A-5	M-1224-5	3/8	9,5		
		15	0,072	1,83	0,606	15,39	0,590	0,661	14,99	16,79	1225-5	R-7-5	1226-5	R-7-A-5	M-1226-5	3/8	9,5		
3/4	19,0	16	0,065	1,65	0,620	15,75	0,605	0,685	15,37	17,40	1227-5	R-7-5	1228-5	R-7-A-5	M-63	3/8	9,5	K50-1250	TES3000 G1000 or TESMini2 DUO
		17	0,058	1,47	0,634	16,10	0,619	0,699	15,72	17,75	1229-5	R-7-5	1230-5	R-7-A-5	M-1230-5	3/8	9,5		
		18	0,049	1,24	0,652	16,56	0,619	0,699	15,72	17,75	1229-5	R-7-5	1230-5	R-7-A-5	M-1230-5	3/8	9,5		
		19	0,042	1,07	0,666	16,92	0,642	0,722	16,31	18,34	1231-5	R-9-5	1232-5	R-9-A-5	M-63	3/8	9,5		
		20	0,035	0,89	0,680	17,27	0,642	0,722	16,31	18,34	1231-5	R-9-5	1232-5	R-9-A-5	M-63	3/8	9,5		
		21	0,032	0,81	0,686	17,42	0,642	0,722	16,31	18,34	1231-5	R-9-5	1232-5	R-9-A-5	M-63	3/8	9,5		
7/8	22,2	22	0,028	0,71	0,694	17,63	0,642	0,722	16,31	18,34	1231-5	R-9-5	1232-5	R-9-A-5	M-63	3/8	9,5	K50-600	TES3000 G1450 or TESMini2 ES2
		13	0,095	2,41	0,685	17,40	0,670	0,750	17,02	19,05	1233-5	R-9-5	1234-5	R-9-A-5	M-64-3/8	3/8	9,5		
		14	0,083	2,11	0,709	18,01	0,685	0,774	17,40	19,66	1235-5	R-10-5	1236-5	R-10-A-5	M-65	3/8	9,5		
		16	0,065	1,65	0,745	18,92	0,726	0,815	18,44	20,70	1239-5	R-11-5	1240-5	R-11-A-5	M-1240-5	3/8	9,5		
		17	0,058	1,47	0,759	19,28	0,740	0,829	18,80	21,06	1243-5	R-11-5	1244-5	R-11-A-5	M-67-3/8	3/8	9,5		
		18	0,049	1,24	0,777	19,74	0,740	0,829	18,80	21,06	1243-5	R-11-5	1244-5	R-11-A-5	M-67-3/8	3/8	9,5		
		19	0,042	1,07	0,791	20,09	0,763	0,852	19,38	21,64	1245-5	R-11-5	1246-5	R-11-A-5	M-68-3/8	3/8	9,5		
20	0,035	0,89	0,805	20,45	0,763	0,852	19,38	21,64	1245-5	R-11-5	1246-5	R-11-A-5	M-68-3/8	3/8	9,5				
21	0,032	0,81	0,811	20,60	0,763	0,852	19,38	21,64	1245-5	R-11-5	1246-5	R-11-A-5	M-68-3/8	3/8	9,5				
22	0,028	0,71	0,819	20,80	0,763	0,852	19,38	21,64	1245-5	R-11-5	1246-5	R-11-A-5	M-68-3/8	3/8	9,5				

1200-5 Five Roll Series

TUBE OD		TUBE GAUGE		TUBE ID		EXPANSION RANGE				TUBE SHEET THICKNESS				MANDREL		MANDREL SQUARE		PNEUMATIC MOTOR *	ELECTRIC MOTOR *
										1/2" TO 6"		2-1/4" TO 6-3/4"							
[INCH]	[MM]	[BWG]	[INCH]	[MM]	[INCH]	[MM]	MIN	MAX	MIN	MAX	TOOL NO.	ROLL NO.	TOOL NO.	ROLL NO.	[INCH]	[MM]			
1	25,4	12	0,109	2,77	0,782	19,86	0,763	0,852	19,38	21,64	1245-5	R-11-5	1246-5	R-11-A-5	M-68-3/8	3/8	9,5	K50-600	TES3000 G1450 or TESMini2 ES2
		13	0,095	2,41	0,810	20,57	0,791	0,880	20,09	22,35	1247-5	R-13-5	1248-5	R-13-A-5	M-68-3/8	3/8	9,5		
		14	0,083	2,11	0,834	21,18	0,810	0,909	20,57	23,09	1249-5	R-12-5	1250-5	R-12-A-5	M-1250-5	3/8	9,5		
		15	0,072	1,83	0,856	21,74	0,837	0,936	21,26	23,77	1251-5	R-14-5	1252-5	R-14-A-5	M-1252-5	3/8	9,5		
		16	0,065	1,65	0,87	22,10	0,837	0,936	21,26	23,77	1251-5	R-14-5	1252-5	R-14-A-5	M-1252-5	3/8	9,5		
		17	0,058	1,47	0,884	22,45	0,865	0,964	21,97	24,49	1255-5	R-13-5	1256-5	R-13-A-5	M-1256-5	3/8	9,5		
	18	0,049	1,24	0,902	22,91	0,865	0,964	21,97	24,49	1255-5	R-13-5	1256-5	R-13-A-5	M-1256-5	3/8	9,5	K50-1250	TES3000 G1000 or TESMini2 DU0	
	19	0,042	1,07	0,916	23,27	0,865	0,964	21,97	24,49	1255-5	R-13-5	1256-5	R-13-A-5	M-1256-5	3/8	9,5			
	20	0,035	0,89	0,93	23,62	0,865	0,964	21,97	24,49	1255-5	R-13-5	1256-5	R-13-A-5	M-1256-5	3/8	9,5			
	21	0,032	0,81	0,936	23,77	0,883	0,982	22,43	24,94	1257-5	R-15-5	1258-5	R-15-A-5	M-71-3/8	3/8	9,5			
	22	0,028	0,71	0,944	23,98	0,883	0,982	22,43	24,94	1257-5	R-15-5	1258-5	R-15-A-5	M-71-3/8	3/8	9,5			
	12	0,109	2,77	0,907	23,04	0,883	0,982	22,43	24,94	1259-5	R-15-5	1258-5	R-15-A-5	M-71-3/8	3/8	9,5			K60-400
13	0,095	2,41	0,935	23,75	0,916	1,015	23,27	25,78	1259-5	R-16-5	1260-5	R-16-A-5	M-1260-5	1/2	12,7				
1-1/4	31,7	14	0,083	2,11	0,959	24,36	0,935	1,044	23,75	26,52	1261-5	R-17-5	1262-5	R-17-A-5	M-1262-5	1/2	12,7	K60-400	TES3000 G1000 or TESMini2 DU1
		15	0,072	1,83	1,106	28,09	1,087	1,196	27,61	30,38	1275-5	R-21-5	1276-5	R-21-A-5	M-1276-5	1/2	12,7		
		16	0,065	1,65	1,120	28,45	1,087	1,196	27,61	30,38	1275-5	R-21-5	1276-5	R-21-A-5	M-1276-5	1/2	12,7		
		17	0,058	1,47	1,134	28,80	1,115	1,231	28,32	31,27	1279-5	R-21-5	1280-5	R-21-A-5	M-1280-5	1/2	12,7		
		18	0,049	1,24	1,152	29,26	1,115	1,231	28,32	31,27	1279-5	R-21-5	1280-5	R-21-A-5	M-1280-5	1/2	12,7		
		19	0,042	1,07	1,166	29,62	1,115	1,231	28,32	31,27	1279-5	R-21-5	1280-5	R-21-A-5	M-1280-5	1/2	12,7		
		20	0,035	0,89	1,180	29,97	1,115	1,231	28,32	31,27	1279-5	R-21-5	1280-5	R-21-A-5	M-1280-5	1/2	12,7		
		21	0,032	0,81	1,186	30,12	1,115	1,231	28,32	31,27	1279-5	R-21-5	1280-5	R-21-A-5	M-1280-5	1/2	12,7		
1-3/8	34,9	22	0,028	0,71	1,194	30,33	1,115	1,231	28,32	31,27	1279-5	R-21-5	1280-5	R-21-A-5	M-1280-5	1/2	12,7	K60-250	
		12	0,109	2,77	1,157	29,39	1,133	1,242	28,78	31,55	1281-5	R-21-5	1282-5	R-21-A-5	M-1282-5	1/2	12,7		
1-1/2	38,1	14	0,083	2,11	1,209	30,71	1,179	1,294	29,95	32,87	1285-5	R-23-5	1286-5	R-23-A-5	M-1282-5	1/2	12,7	K60-900	TES3000 G1000 or TESMini2 ES2
		17	0,058	1,47	1,384	35,15	1,331	1,472	33,81	37,39	1299-5	R-29-5	1300-5	R-29-A-5	M-1300-5	1/2	12,7		
		18	0,049	1,24	1,402	35,61	1,331	1,472	33,81	37,39	1299-5	R-29-5	1300-5	R-29-A-5	M-1300-5	1/2	12,7		
		19	0,042	1,07	1,416	35,97	1,331	1,472	33,81	37,39	1299-5	R-29-5	1300-5	R-29-A-5	M-1300-5	1/2	12,7		
		20	0,035	0,89	1,430	36,32	1,331	1,472	33,81	37,39	1299-5	R-29-5	1300-5	R-29-A-5	M-1300-5	1/2	12,7		
		21	0,032	0,81	1,436	36,47	1,331	1,472	33,81	37,39	1299-5	R-29-5	1300-5	R-29-A-5	M-1300-5	1/2	12,7		
22	0,028	0,71	1,444	36,68	1,331	1,472	33,81	37,39	1299-5	R-29-5	1300-5	R-29-A-5	M-1300-5	1/2	12,7				

* Motor recommendation applies only to most popular cases with a standard percentage of the wall reduction. The recommendation can be different for thicker tube sheet, harder and exotic metal tube and a higher percentage of wall reduction.

RECOMMENDATION

Recommended order of step by step expanding in a thick tube sheets in order to avoid tension between both tube sheets after rolling.

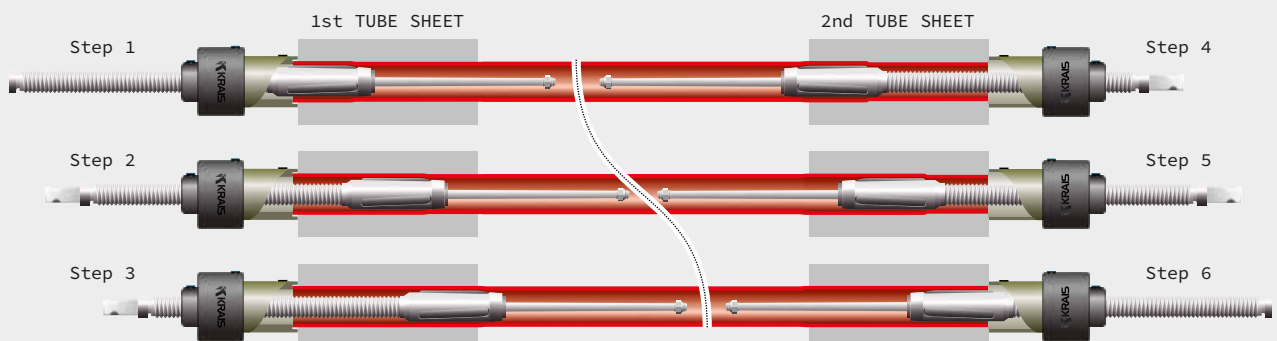

8012 Series

KRAIS 8012 series expanders are intended for larger tube diameters in heat exchanger work. They bridge the gap where the 800 and 1200 ranges are no longer sufficient, yet controlled expansion for exchanger joints remains necessary. These tools provide the robust torque and precise control required for larger scale industrial heat exchangers.



WORKING RANGE

TUBE ID	TUBE OD	TUBE SHEET
8,48 - 36,32 mm	44,4 - 76,2 mm	12,7 - 101,6 mm
0,334 - 1,430"	1-3/4" to 3"	1-1/2" to 2-1/4"

ADDITIONAL INFORMATION



How-to basics
→ PAGE 11



Rolls range
→ PAGE 10



Rolling motors
→ PAGE 45

TUBE OD		TUBE GAUGE		TUBE ID		EXPANSION RANGE				TOOL NO.	ROLL NO.	MANDREL	MANDREL	PNEUMATIC MOTOR *	ELECTRIC MOTOR *	
[INCH]	[MM]	[BWG]	[INCH]	[MM]	[INCH]	[MM]	MIN	MAX	MIN							MAX
1-3/4	44,4	8	0,165	4,19	1,42	36,07	1,368	1,55	34,75	39,37	8012-1-3/4-8	R-33-A	M-90	3/4	K60-400	TESMini2 DU1
		10	0,134	3,40	1,482	37,64	1,420	1,607	36,07	40,82	8012-1-3/4-10	R-37-A	M-90	3/4		
		11	0,120	3,05	1,510	38,35	1,454	1,635	36,93	41,53	8012-1-3/4-11	R-42	M-90	3/4		
		12	0,109	2,77	1,532	38,91	1,482	1,657	37,64	42,09	8012-1-3/4-12	R-44	M-90	3/4		
		13	0,095	2,41	1,560	39,62	1,510	1,685	38,35	42,80	8012-1-3/4-13	R-46	M-90	3/4		
		14	0,083	2,11	1,584	40,23	1,532	1,709	38,91	43,41	8012-1-3/4-14	R-48	M-90	3/4		
2	50,8	8	0,165	4,19	1,670	42,42	1,595	1,795	40,51	45,59	8012-2-8	R-48	M-91	3/4	K60-250	TESMini2 K90-E-190
		10	0,134	3,40	1,732	43,99	1,640	1,857	41,66	47,17	8012-2-10	R-50	M-91	3/4		
		11	0,120	3,05	1,760	44,70	1,670	1,885	42,42	47,88	8012-2-11	R-52	M-91	3/4		
		12	0,109	2,77	1,782	45,26	1,704	1,907	43,28	48,44	8012-2-12	R-54	M-91	3/4		
		13	0,095	2,41	1,810	45,97	1,732	1,956	43,99	49,68	8012-2-13-18	R-56	M-91	3/4		
		14	0,083	2,11	1,834	46,58	1,732	1,956	43,99	49,68	8012-2-13-18	R-56	M-91	3/4		
		15	0,072	1,83	1,856	47,14	1,732	1,956	43,99	49,68	8012-2-13-18	R-56	M-91	3/4		
		16	0,065	1,65	1,870	47,50	1,732	1,956	43,99	49,68	8012-2-13-18	R-56	M-91	3/4		
2-1/4	57,1	10	0,134	3,40	1,982	50,34	1,890	2,107	48,01	53,52	8012-2-1/4-10	R-56	M-92	3/4	K60-250	TESMini2 K90-E-190
		11	0,120	3,05	2,010	51,05	1,920	2,135	48,77	54,23	8012-2-1/4-11	R-58	M-92	3/4		
		12	0,109	2,77	2,032	51,61	1,954	2,157	49,63	54,79	8012-2-1/4-12	R-60	M-92	3/4		
		13	0,095	2,41	2,060	52,32	1,982	2,185	50,34	55,50	8012-2-1/4-13-16	R-62	M-92	3/4		
		14	0,083	2,11	2,084	52,93	1,982	2,185	50,34	55,50	8012-2-1/4-13-16	R-62	M-92	3/4		
		15	0,072	1,83	2,106	53,49	1,982	2,185	50,34	55,50	8012-2-1/4-13-16	R-62	M-92	3/4		
		16	0,065	1,65	2,120	53,85	1,982	2,185	50,34	55,50	8012-2-1/4-13-16	R-62	M-92	3/4		

8012 Series

TUBE OD		TUBE GAUGE		TUBE ID		EXPANSION RANGE				TOOL NO.	ROLL NO.	MANDREL	MANDREL [INCH]	PNEUMATIC MOTOR *	ELECTRIC MOTOR *	
[INCH]	[MM]	[BWG]	[INCH]	[MM]	[INCH]	[MM]	MIN	MAX	MIN							MAX
2-1/2	63,5	10	0,134	3,40	2,232	56,69	2,140	2,407	54,36	61,14	8012-2-1/2-10-12	R-64	M-93	3/4	K60-250	TESMini2 K90-E-190
		11	0,120	3,05	2,260	57,40	2,140	2,407	54,36	61,14	8012-2-1/2-10-12	R-64	M-93	3/4		
		12	0,109	2,77	2,282	57,96	2,140	2,407	54,36	61,14	8012-2-1/2-10-12	R-64	M-93	3/4		
		13	0,095	2,41	2,310	58,67	2,232	2,450	56,69	62,23	8012-2-1/2-13-18	R-64	M-94	3/4		
		14	0,083	2,11	2,334	59,28	2,232	2,450	56,69	62,23	8012-2-1/2-13-18	R-64	M-94	3/4		
		15	0,072	1,83	2,356	59,84	2,232	2,450	56,69	62,23	8012-2-1/2-13-18	R-64	M-94	3/4		
		16	0,065	1,65	2,370	60,20	2,232	2,450	56,69	62,23	8012-2-1/2-13-18	R-64	M-94	3/4		
		17	0,058	1,47	2,384	60,55	2,232	2,450	56,69	62,23	8012-2-1/2-13-18	R-64	M-94	3/4		
2-3/4	69,8	10	0,134	3,40	2,482	63,04	2,390	2,702	60,71	68,63	8012-2-3/4-10-16	R-66	M-96	1	K72-RT-90	TESMini2 K90-E-90
		11	0,120	3,05	2,510	63,75	2,390	2,702	60,71	68,63	8012-2-3/4-10-16	R-66	M-96	1		
		12	0,109	2,77	2,532	64,31	2,390	2,702	60,71	68,63	8012-2-3/4-10-16	R-66	M-96	1		
		13	0,095	2,41	2,560	65,02	2,390	2,702	60,71	68,63	8012-2-3/4-10-16	R-66	M-96	1		
		14	0,083	2,11	2,584	65,63	2,390	2,702	60,71	68,63	8012-2-3/4-10-16	R-66	M-96	1		
		15	0,072	1,83	2,606	66,19	2,390	2,702	60,71	68,63	8012-2-3/4-10-16	R-66	M-96	1		
3	76,2	8	0,165	4,19	2,670	67,82	2,560	2,829	65,02	71,86	8012-3-8-9	R-67	M-97	1	K72-RT-90	TESMini2 K90-E-90
		9	0,148	3,76	2,704	68,68	2,560	2,829	65,02	71,86	8012-3-8-9	R-67	M-97	1		
		10	0,134	3,40	2,732	69,39	2,640	2,952	67,06	74,98	8012-3-10-18	R-67	M-96	1		
		11	0,120	3,05	2,760	70,10	2,640	2,952	67,06	74,98	8012-3-10-18	R-67	M-96	1		
		12	0,109	2,77	2,782	70,66	2,640	2,952	67,06	74,98	8012-3-10-18	R-67	M-96	1		
		13	0,095	2,41	2,810	71,37	2,640	2,952	67,06	74,98	8012-3-10-18	R-67	M-96	1		
		14	0,083	2,11	2,834	71,98	2,640	2,952	67,06	74,98	8012-3-10-18	R-67	M-96	1		
		15	0,072	1,83	2,856	72,54	2,640	2,952	67,06	74,98	8012-3-10-18	R-67	M-96	1		
		16	0,065	1,65	2,870	72,90	2,640	2,952	67,06	74,98	8012-3-10-18	R-67	M-96	1		
		17	0,058	1,47	2,884	73,25	2,640	2,952	67,06	74,98	8012-3-10-18	R-67	M-96	1		
18	0,049	1,24	2,902	73,72	2,640	2,952	67,06	74,98	8012-3-10-18	R-67	M-96	1				

* Motor recommendation applies only to most popular cases with a standard percentage of the wall reduction. The recommendation can be different for thicker tube sheet, harder and exotic metal tube and a higher percentage of wall reduction.

i RECOMMENDATION

When rolling a pipe in a thick tube sheet, we recommend initial rolling to a minimum of 1/2 inch, followed by rolling deeper into the pipe in subsequent steps.

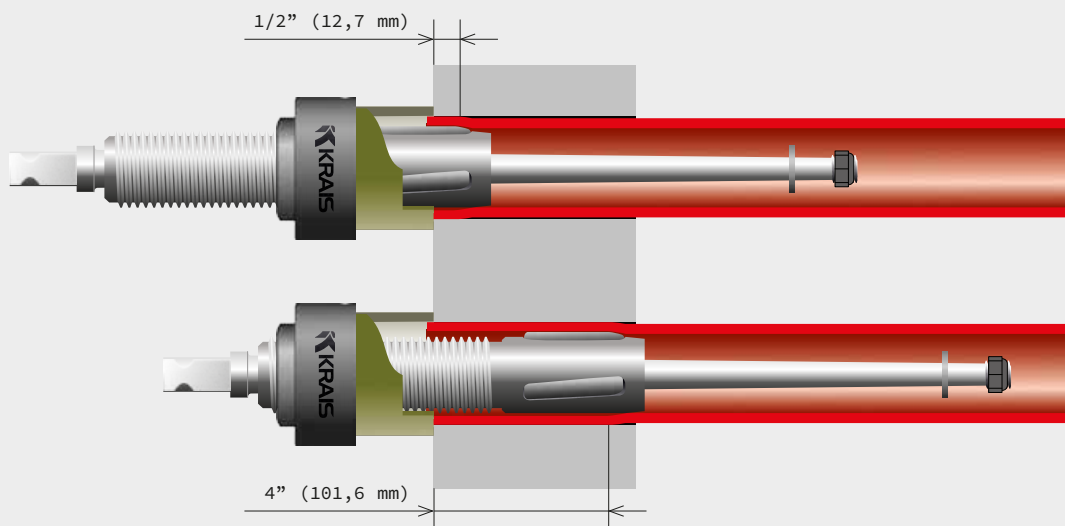

F600 Flare Type Series

KRAIS F600 series performs tube expansion and end flaring in a single operation. Use it where specifications call for a flared tube end as a mechanical feature or to eliminate variability from separate flaring steps. Tight control of tube projection and flare geometry ensures consistent results and high productivity in specialized applications.



WORKING RANGE

TUBE ID	TUBE OD	TUBE SHEET
13,51 – 22,45 mm	15,8 - 25,4 MM	38,1 - 57,1 MM
0,532 - 0,884"	5/8" to 1"	1-1/2" to 2-1/4"

ADDITIONAL INFORMATION



How-to basics
→ PAGE 11



Rolls range
→ PAGE 10



Rolling motors
→ PAGE 45

RECOMMENDATION

When using the F-600 series expander make sure that the flare length is correctly set up and the thrust collar rest against the tube sheet.

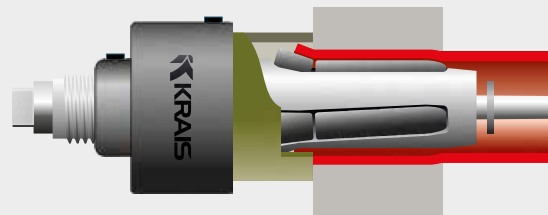

TUBE ID		ROLL LENGTH 1-1/2" (38,1 MM)		ROLL LENGTH 2-1/4" (57,1 MM)		EXPANSION RANGE				FLARE ROLL	MANDREL	RECCOMENDED DRIVE*	
[INCH]	[MM]	TOOL NO.	ROLL NO.	TOOL NO.	ROLL NO.	[INCH]		[MM]				ELECTRIC	PNEUMATIC
0,532	13,51	619	K-7	620	K-7A	0,511	0,570	12,98	14,48	F-8	M-6	TESMini 2, ES2	K50-600
0,560	14,22	621	K-8	622	K-8A	0,539	0,606	13,69	15,39	F-8	M-8	TESMini 2, ES2	K50-600
0,584	14,83	623	K-9	624	K-9A	0,562	0,629	14,27	15,98	F-9	M-8	TESMini 2, ES2	K50-600
0,606	15,39	625	K-10	626	K-10A	0,586	0,649	14,88	16,48	F-10	M-8	TESMini 2, ES2	K50-600
0,620	15,75	627	K-10	628	K-10A	0,594	0,677	15,09	17,20	F-10	M-9	TESMini 2, ES2	K50-600
0,634	16,10	629	K-11	630	K-11 A	0,610	0,688	15,49	17,48	F-11	M-9	TESMini 2, ES2	K50-400
0,657	16,69	631	K-12	632	K-12A	0,633	0,712	16,08	18,08	F-12	M-9	TESMini 2, ES2	K50-400
0,670	17,02	641	K-13	642	K-13A	0,645	0,724	16,38	18,39	F-13	M-9	TESMini 2, ES2	K50-400
0,685	17,40	633	K-13	634	K-13A	0,661	0,740	16,79	18,80	F-13	M-10	TESMini 2, ES2	K50-400
0,709	18,01	635	K-14	636	K-14A	0,677	0,763	17,20	19,38	F-14	M-11	TESMini 2, ES2	K60-900
0,731	18,57	637	K-15	638	K-15A	0,700	0,791	17,78	20,09	F-15	M-11	TESMini 2, ES2	K60-900
0,745	18,92	639	K-15	640	K-15A	0,716	0,807	18,19	20,50	F-15	M-12	TESMini 2, ES2	K60-900
0,760	19,30	643	K-16	644	K-16A	0,732	0,818	18,59	20,78	F-16	M-12	TESMini 2, DU1	K60-900
0,782	19,86	645	K-17	646	K-17A	0,751	0,842	19,08	21,39	F-17	M-12	TESMini 2, DU1	K60-900
0,795	20,19	653	K-20	654	K-20A	0,767	0,866	19,48	22,00	F-20	M-13	TESMini 2, DU1	K60-900
0,810	20,57	647	K-18	648	K-18A	0,779	0,870	19,79	22,10	F-18	M-12	TESMini 2, DU1	K60-900
0,834	21,18	649	K-18	650	K-18A	0,799	0,897	20,29	22,78	F-18	M-13	TESMini 2, DU1	K60-900
0,856	21,74	651	K-19	652	K-19A	0,826	0,921	20,98	23,39	F-19	M-13	TESMini 2, DU1	K60-900
0,884	22,45	655	K-21	656	K-21A	0,854	0,948	21,69	24,08	F-21	M-13	TESMini 2, DU1	K60-900

* Motor recommendation applies only to most popular cases with a standard percentage of the wall reduction. The recommendation can be different for thicker tube sheet, harder and exotic metal tube and a higher percentage of wall reduction.

TACK Conical Series

KRAIS TACK series delivers short, controlled conical expansion as preparation for welding. Used in rolled-and-welded joints, it removes clearance and stabilizes the tube to improve weld conditions. The conical profile provides maximum expansion close to the tube end, while the length is selected to match the intended weld zone requirements.



WORKING RANGE

TUBE ID		TUBE OD
8,0 - 50,0 mm		9,5 - 50,8 mm
0,315 - 1,969"		3/8" to 1"

ADDITIONAL INFORMATION



How-to basics
→ PAGE 11



Rolls range
→ PAGE 10



Rolling motors
→ PAGE 45

RECOMMENDATION

Proper rolling and preparation of thin-walled tube for welding using the TACK tube expander.

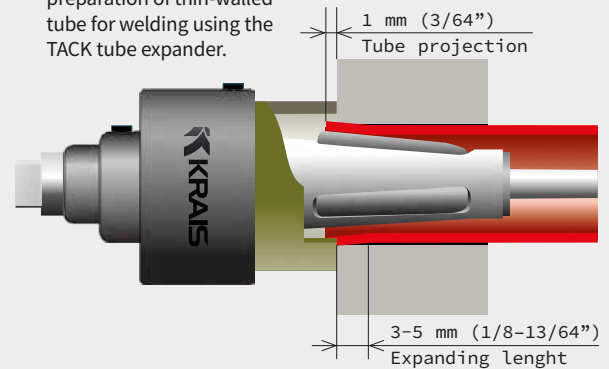

EXPANSION RANGE				TOOL	ROLLS	MANDREL	MANDREL SQUARE		RECOMMENDED MOTOR *	
[MM]		[INCH]					[MM]	[INCH]	AIR	ELECTRIC
MIN	MAX	MIN	MAX							
7,80	9,90	0,307	0,390	TRE-797	R-797	M-797	9,5	3/8	K20-1800	TesMini 2 with HT-0
8,60	11,00	0,339	0,433	TRE-801	R-1	M-1	9,5	3/8	K20-1800	TesMini 2 with HT-0
9,40	12,00	0,370	0,472	TRE-805	R-3	M-2	9,5	3/8	K20-1800	TesMini 2 with HT-0
11,30	14,30	0,445	0,563	TRE-811	R-5	M-5	9,5	3/8	K20-1800	TesMini 2 with HT-0
11,90	15,10	0,469	0,594	TRE-815	R-6	M-6	9,5	3/8	K20-1800	TesMini 2 with HT-0
12,30	15,60	0,484	0,614	TRE-819	R-7	M-6	9,5	3/8	K20-1800	TesMini 2 with HT-0
13,70	17,00	0,539	0,669	TRE-823	R-9	M-8	9,5	3/8	K20-1800	TesMini 2 with HT-0
15,50	19,10	0,610	0,752	TRE-831	R-12	M-9	9,5	3/8	K20-550	TesMini 2 with DU-0
16,20	19,80	0,638	0,780	TRE-833	R-13	M-10	9,5	3/8	K20-550	TesMini 2 with DU-0
17,90	21,85	0,705	0,860	TRE-843	R-16	M-12	9,5	3/8	K20-550	TesMini 2 with DU-0
19,70	23,90	0,776	0,941	TRE-849	R-18	M-13	9,5	3/8	K20-550	TesMini 2 with DU-0
21,10	25,30	0,831	0,996	TRE-855	R-21	M-13	9,5	3/8	K50-1250	TesMini 2 with DU-0
23,50	28,00	0,925	1,102	TRE-863	R-24	M-15	12,7	1/2	K50-1250	TesMini 2 with DU-0
25,60	30,00	1,008	1,181	TRE-871	R-28	M-17	12,7	1/2	K50-1250	TesMini 2 with DU-0
27,90	32,35	1,098	1,274	TRE-881	R-32	M-18	12,7	1/2	K50-1250	TesMini 2 with DU-0
29,10	33,70	1,146	1,327	TRE-885	R-34	M-20	12,7	1/2	K50-600	TesMini 2 with DU-0
31,80	36,40	1,252	1,433	TRE-895	R-37	M-21	12,7	1/2	K50-600	TesMini 2 with DU-0
32,90	38,20	1,295	1,504	TRE-899	R-38	M-22	12,7	1/2	K50-600	TesMini 2 with DU-1
36,40	43,20	1,433	1,701	TRE-9012-13/4-12	R-44	M-90	19,1	3/4	K60-900	TesMini 2 with DU-1
39,20	46,80	1,543	1,843	TRE-8012-175-14	R-48	M-91	19,1	3/4	K60-900	TesMini 2 with DU-1
41,20	49,10	1,622	1,933	TRE-8012-2-11	R-52	M-91	19,1	3/4	K60-900	TesMini 2 with DU-1
42,60	50,90	1,677	2,004	TRE-8012-2-13-18	R-56	M-91	19,1	3/4	K60-900	TesMini 2 with DU-1
46,70	54,80	1,839	2,157	TRE-8012-2-1/4-10	R-56	M-92	19,1	3/4	K60-900	TesMini 2 with DU-1

* Motor recommendation applies only to most popular cases with a standard percentage of the wall reduction. The recommendation can be different for thicker tube sheet, harder and exotic metal tube and a higher percentage of wall reduction.

Special expanders

REFINERY TUBE EXPANDER

Tube expander for straight rolling or rolling and flaring very thick-walled tubes in cracking furnace tube seats for tubes outside diameter from 50 to 250 mm (2"-10") and gauges from 6 to 15 mm (0,19" to 0,59"). Flaring 10 to 15 degree. Roll length 38,1 to 101 mm (1-1/2" - 4"). Made on request to drawing of the tube seat.

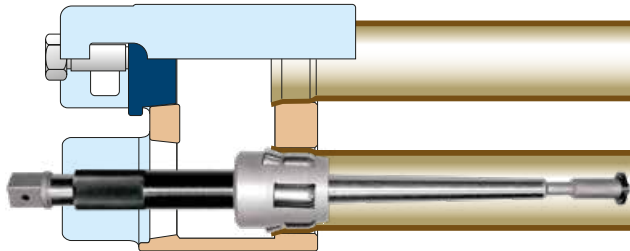

SUGAR REFINERY EXPANDER

These are fixed rolling length special purpose tools which may be power or hand-driven. They are self-feeding parallel-rolling type. When ordering please give precise details of vessel in which the expander is to be used, quoting size and length of tube, distance over tube plates, tube plate thickness and any tube projection details. Ideally a drawing should be provided.

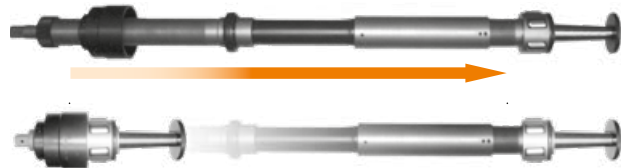
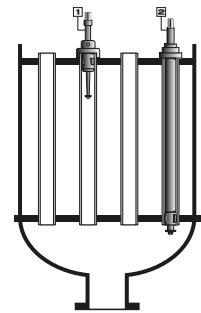

NOTCHING & EXPANDING



NE notching&expanding type tube expander for thin tube sheet and thin wall tubes. Expand and notch the tube in one operation. The notches lock the tube in front and back side of the tube sheet and prevent to unseal during the transportation or expanding the near by and already expanded tubes. The expansion range is adjustable within 0,005 mm. Do not need the torque controlled drive.



STEP-BY-STEP



STEP-BY-STEP expander are an excellent tool for fast tube rolling in thick tube sheets, from 6" to 24". The Expanders have grooves spaced at 1" (25,4 mm) increments along the cage of the tool, which allows the spring loaded thrust collar, to quickly and efficiently travel along the complete length of the tool. Significant time savings are achieved with this fast step rolling throughout the full width of the tube sheet.

PSE PIPE



PSE expanders are designed to true up the ends of pipe and also to enlarge pipe inside diameters to a specific size in order to create the correct clearance between the pipe OD and ID prior to brazing or silver soldering. The Threaded mandrel allows fast and accurate sizing of the pipe end. Available up to 8" OD.

TWTC



5-Roll expander with TWTC thin wall thrust collar.

LUBRICATION-COOLING BOX



Condenser tube expander with cooling-lubricating box. Made upon order only.

Special expanders

LINSEN EXPANDERS



LINSEN expanders can be driven by electric or pneumatic drills. Designed to produce tube end connections without fittings. Enlarges tube end without distortions or buckling and leaving.



0,015" (0,38 mm) clearance that another tube with the same outside diameter can be inserted and soldered. It is excellent for U-tubes, short bends, for copper, brass aluminium and thin steel tubes. Available from 3/8" (9,5 mm) to 2" (50,8 mm). For more details contact factory.

SR EXPANDERS



SR series expanders are designed for expanding tubes with minimum travel of mandrel. Expander mandrel is short and it allows to use SR expanders near tube bends or ID fixed tubes.

BAFFLE TUBE EXPANDERS

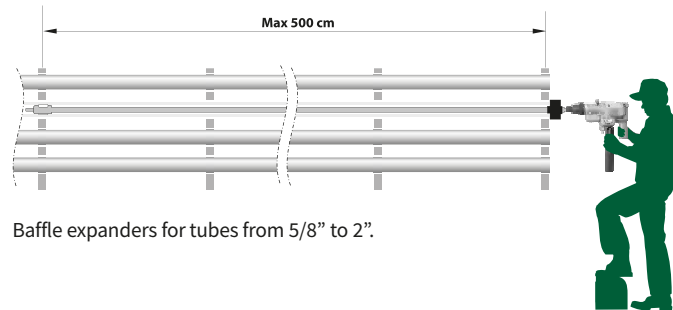

Baffle expanders for tubes from 5/8" to 2".

5-ROLL EXPANDER WITH NYLON BUSH



5-Roll expander with nylon bush in front of the cage to protect to the tubes from the scratches. Used for titanium tubes.

AVAILABLE SOON

Heat Exchanger & Condenser Cleaning Systems



Boiler Tube Expanders

Correct tool selection

EXPANDER TYPES

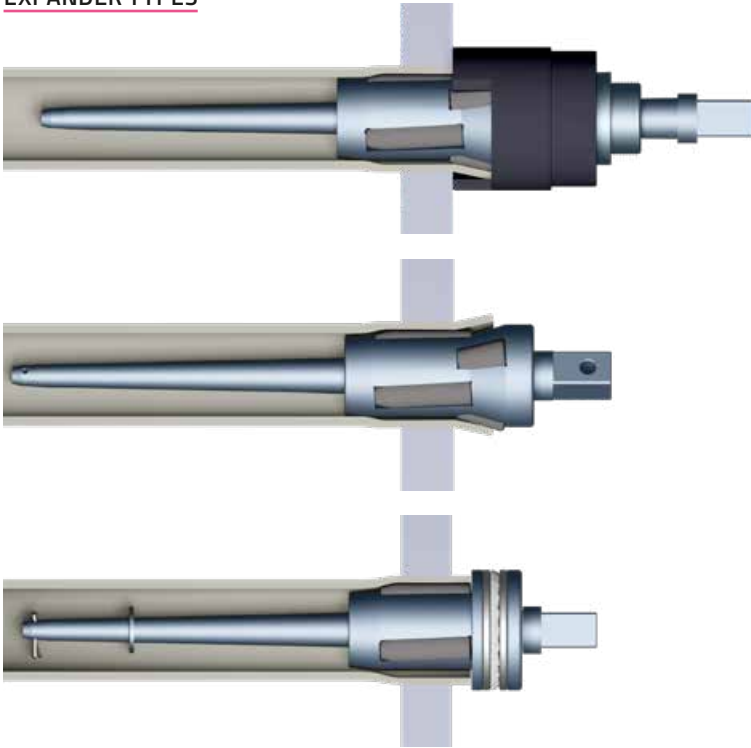

FTKS SERIES

- ▶ This expander will simultaneously expand and flare the tubes in 1 single operation. An adjustable collar with a ball bearing prevents the cage and flare rolls to penetrate too much inside the tube. Allows consistent expansion and flare even for non-experienced operators. This tool is an excellent expander for re-rolling leaky tubes.

KS SERIES

- ▶ Self-feeding boiler tube expander, simultaneously expands and flare the tube. An excellent expander for re-rolling leaky tubes and new constructions.

PZ SERIES

- ▶ Self-feeding, fixed depth, three roll boiler tube expander with plane collar and ball bearing. An excellent expander for re-rolling leaky tubes and new boilers.

PROPER EXPANDING PROCESS FOR HEAVY TUBE SHEETS AND BOILER DRUMS

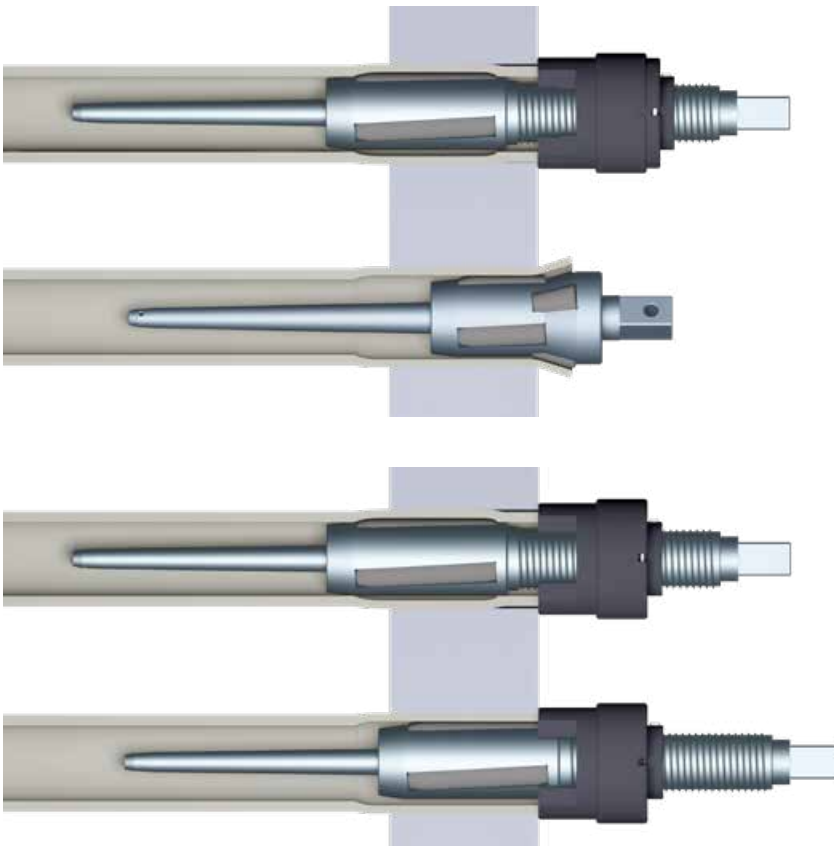

EXPANSION WITH FLARE

1. Insert the tube expander inside the tube; rolls should stick out 8-12 mm behind the drum. Expand the tube until the set torque on the expanding machine is reached (according to the tube's calculated expanded inside diameter).
2. If the expansion with flare is desired, use the KS flare tube expander in the next step. Insert expander into the tube for the depth that will overlap with the first expansion, start next step expanding and flaring. Please note that operation with KS expander may need more than one pass. It depends on the required wall reduction and gap size between the tube and the hole in the drum. The more significant gap requires more passes - it is needed to avoid the cage penetration too much into the tube, which may cause damage to the tube or tool.

EXPANSION WITHOUT FLARE

1. Insert the tube expander inside the tube; rolls should stick out 8-12 mm behind the drum. Expand the tube until the set torque on the expanding machine is reached (according to the tube's calculated expanded inside diameter).
2. If the flare is not desired, then readjust the P2 expander to the required expanding length and finish the expansion as shown in the picture.

Short Mandrel's Expansion Range

MANDREL SET	EXPANSION RANGE ON THE EACH MANDREL												PROTRUDING FROM THE FRONT OF CAGE		SQUARE
	A				B				C						
	[MM]		[INCH]		[MM]		[INCH]		[MM]		[INCH]		MM	INCH	
	MIN	MAX	MIN	MAX	MIN	MAX	MIN	MAX	MIN	MAX	MIN	MAX			
TKK-19	19,00	20,00	0,748	0,787	20,00	21,00	0,787	0,827	21,00	22,00	0,827	0,866	40,00	1,575	1/2"
TKK-20	20,00	21,00	0,787	0,826	21,00	22,00	0,827	0,866	22,00	23,00	0,866	0,906	40,00	1,575	1/2"
TKK-22	22,00	23,00	0,866	0,905	23,00	24,00	0,906	0,945	24,00	25,00	0,945	0,984	40,00	1,575	1/2"
TKK-23	23,00	24,00	0,906	0,944	24,00	25,00	0,945	0,984	25,00	26,00	0,984	1,024	40,00	1,575	1/2"
TKK-24	24,00	25,00	0,945	0,984	25,00	26,00	0,984	1,024	26,00	27,00	1,024	1,063	40,00	1,575	1/2"
TKK-25	25,00	26,00	0,984	1,023	26,00	27,00	1,024	1,063	27,00	28,00	1,063	1,102	40,00	1,575	1/2"
TKK-27	27,00	28,00	1,063	1,102	28,00	29,00	1,102	1,142	29,00	30,00	1,142	1,181	40,00	1,575	1/2"
TKK-28	28,00	29,30	1,102	1,153	29,30	30,60	1,154	1,205	30,60	32,00	1,205	1,260	50,00	1,969	1/2"
TKK-29	29,00	30,30	1,142	1,192	30,30	31,60	1,193	1,244	31,60	33,00	1,244	1,299	50,00	1,969	1/2"
TKK-30	30,00	31,30	1,181	1,232	31,30	32,60	1,232	1,283	32,60	34,00	1,283	1,339	50,00	1,969	1/2"
TKK-32	32,00	33,30	1,260	1,311	33,30	34,60	1,311	1,362	34,60	36,00	1,362	1,417	50,00	1,969	1/2"
TKK-37*1	35,00	37,00	1,378	1,456	37,00	39,00	1,457	1,535	39,00	41,00	1,535	1,614	65,00	2,559	3/4"
TKK-37	37,00	39,00	1,457	1,535	39,00	41,00	1,535	1,614	41,00	43,00	1,614	1,693	65,00	2,559	3/4"
TKK-42*2	40,00	42,00	1,575	1,653	42,00	44,00	1,654	1,732	44,00	46,00	1,732	1,811	65,00	2,559	3/4"
TKK-42	42,00	44,00	1,654	1,732	44,00	46,00	1,732	1,811	46,00	48,00	1,811	1,890	65,00	2,559	3/4"
TKK-44	44,00	46,00	1,732	1,811	46,00	48,00	1,811	1,890	48,00	50,00	1,890	1,969	65,00	2,559	3/4"
TKK-47	47,00	49,40	1,850	1,944	49,40	51,70	1,945	2,035	51,70	54,00	2,035	2,126	75,00	2,953	3/4"
TKK-49	49,00	51,40	1,929	2,023	51,40	53,70	2,024	2,114	53,70	56,00	2,114	2,205	75,00	2,953	3/4"
TKK-49*3	52,00	54,60	2,047	2,149	54,40	56,90	2,142	2,240	57,70	59,20	2,272	2,331	75,00	2,953	3/4"
TKK-54	54,00	56,60	2,126	2,228	56,60	59,30	2,228	2,335	59,30	62,00	2,335	2,441	82,00	3,228	3/4"
TKK-57	57,00	60,00	2,244	2,362	60,00	63,00	2,362	2,480	63,00	66,00	2,480	2,598	90,00	3,543	3/4"
TKK-65*4	60,00	63,00	2,362	2,480	63,00	66,00	2,480	2,598	66,00	69,00	2,598	2,717	90,00	3,543	3/4"
TKK-65	65,00	68,00	2,559	2,677	68,00	71,00	2,677	2,795	71,00	74,00	2,795	2,913	90,00	3,543	3/4"
TKK-72*5	68,00	71,40	2,677	2,811	71,40	74,70	2,811	2,941	74,70	78,00	2,941	3,071	100,00	3,937	1"
TKK-72	72,00	75,30	2,835	2,964	75,40	78,60	2,969	3,094	78,70	82,00	3,098	3,228	100,00	3,937	1"
TKK-77	77,00	80,40	3,031	3,165	80,40	83,70	3,165	3,295	83,70	87,00	3,295	3,425	100,00	3,937	1"
TKK-82	82,00	85,40	3,228	3,362	85,40	88,70	3,362	3,492	88,70	92,00	3,492	3,622	100,00	3,937	1"
TKK-86	86,00	89,40	3,386	3,519	89,40	92,70	3,520	3,650	92,70	96,00	3,650	3,780	100,00	3,937	1"
TKK-90	90,00	94,00	3,543	3,700	94,00	98,00	3,701	3,858	98,00	102,00	3,858	4,016	115,00	4,528	1"
TKK-96	96,00	100,00	3,780	3,937	100,00	104,00	3,937	4,094	104,00	108,00	4,094	4,252	115,00	4,528	1"

- *1 re. expander KS-35
- *2 re. expander KS-40
- *3 re. expander KS-52
- *4 re. expander KS-60
- *5 re. expander KS-68

ROLLS RANGE (SHEET THICKNESS) FOR KS, PZ & FTKS

ROLL LENGTH		TUBE SHEET THICKNESS		AVAILABILITY
[MM]	[INCH]	[INCH]	[MM]	
40	1,574	1/2" - 3/4"	12 - 19	On request
42	1,653	1/2" - 3/4"	12 - 19	Standard
50	1,968	5/8" - 7/8"	16 - 22	Standard
60	2,362	7/8" - 1 1/4"	22 - 32	On request
80	3,149	1 3/8" - 1 3/4"	35 - 45	On request
100	3,937	1 7/8" - 2 1/4"	48 - 58	On special request

BOTTLE ROLLS FOR KS, PZ

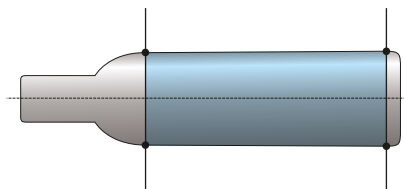

For KS and PZ expanders there are available special bottle type rolls which reduce the effective roll length. Max. for 10 mm from the front of the roll.

KS Series

The KS boiler expanders feature three expansion rolls combined with three flare rolls, offering self-feeding operation and simultaneous tube expansion and flaring. KRAIS KS family covers classic boiler tube expanding tasks, typically used for reliable tube installation as well as repair and re-rolling operations. These tools are engineered for durability and precision in demanding boiler environments. They provide the repeatable performance necessary for maintaining pressure vessel integrity and safety.

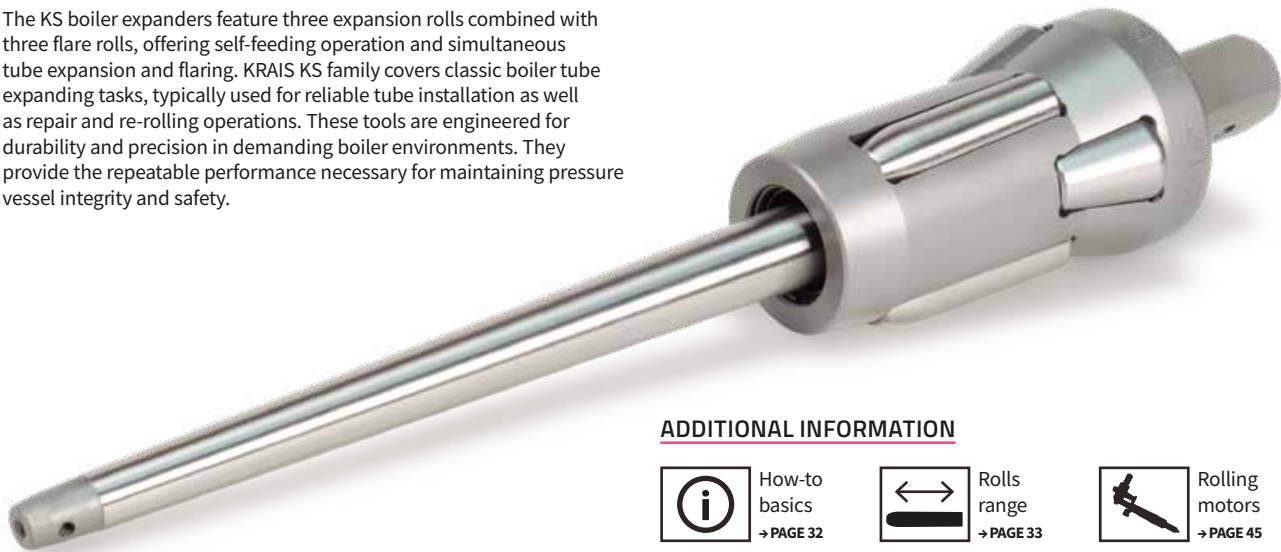

ADDITIONAL INFORMATION



How-to basics
→ PAGE 32



Rolls range
→ PAGE 33



Rolling motors
→ PAGE 45

Tube OD		Tube Gauge	Tool No.	Expansion Range				Rolls			Mandrel		Short Mandrell Set (3 pcs.)			Square	
[inch]	[mm]			[mm]		[inch]		No.	Lenght		No.	Length		No.	Length		
		[BWG]		min	max	min	max		[mm]	[inch]		[mm]	[inch]		[mm]	[inch]	[inch]
1"	25,40	9-11	KS-1942	19,0	22,0	0,75	0,87	RR12RK5/42	42	1,654	TK19	196	7,677	-	-	-	1/2
1"	25,40	13-14	KS-2042	20,0	23,0	0,79	0,91	RR12RK5/42	42	1,654	TK20	196	7,677	-	-	-	1/2
1-1/4"	31,75	7	KS-2242	22,0	25,0	0,87	0,98	RR12RK5/42	42	1,654	TK22	196	7,677	-	-	-	1/2
1-1/4"	31,75	9	KS-2342	23,0	26,0	0,91	1,02	RR13RK6/42	42	1,654	TK23	196	7,677	-	-	-	1/2
1-1/4"	31,75	10	KS-2442	24,0	27,0	0,94	1,06	RR13RK6/42	42	1,654	TK24	196	7,677	-	-	-	1/2
1-1/4"	31,75	11-13	KS-2542	25,0	28,0	0,98	1,10	RR13RK6/42	42	1,654	TK25	196	7,677	-	-	-	1/2
1-1/4"	31,75	12-14	KS-2642	26,0	29,0	1,02	1,14	RR13RK6/42	42	1,654	TK26	196	7,677	-	-	-	1/2
1-1/4"	31,75	14-15	KS-2742	27,0	30,0	1,06	1,18	RR15RK7/42	42	1,654	TK27	196	7,874	-	-	-	1/2
1-1/4"	31,75	16	KS-2842	28,0	32,0	1,10	1,26	RR16RK8/42	42	1,654	TK28	260	10,236	TKK28	175	6,890	3/4
			KS-2850	28,0	32,0	1,10	1,26	RR16RK8/50	50	1,969	TK28	260	10,236	TKK28	175	6,890	3/4
			KS-2860	28,0	32,0	1,10	1,26	RR16RK8/60	60	2,362	TK28	260	10,236	TKK28	175	6,890	3/4
			KS-2880	28,0	32,0	1,10	1,26	RR16RK8/80	80	3,150	TK28	260	10,236	TKK28	175	6,890	3/4
1-1/2"	38,10	7-10	KS-2942	29,0	33,0	1,14	1,30	RR16RK8/42	42	1,654	TK29	260	10,236	TKK29	175	6,890	3/4
			KS-2950	29,0	33,0	1,14	1,30	RR16RK8/50	50	1,969	TK29	260	10,236	TKK29	175	6,890	3/4
			KS-2960	29,0	33,0	1,14	1,30	RR16RK8/60	60	2,362	TK29	260	10,236	TKK29	175	6,890	3/4
			KS-2980	29,0	33,0	1,14	1,30	RR16RK8/80	80	3,150	TK29	260	10,236	TKK29	175	6,890	3/4
1-1/2"	38,10	10-12	KS-3042	30,0	34,0	1,18	1,34	RR16RK8/42	42	1,654	TK30	260	10,236	TKK30	175	6,890	3/4
			KS-3050	30,0	34,0	1,18	1,34	RR16RK8/50	50	1,969	TK30	260	10,236	TKK30	175	6,890	3/4
			KS-3060	30,0	34,0	1,18	1,34	RR16RK8/60	60	2,362	TK30	260	10,236	TKK30	175	6,890	3/4
			KS-3080	30,0	34,0	1,18	1,34	RR16RK8/80	80	3,150	TK30	260	10,236	TKK30	175	6,890	3/4
1-1/2"	38,10	12-14	KS-3242	32,0	36,0	1,26	1,42	RR17RK9/42	42	1,654	TK32	260	10,236	TKK32	175	6,890	3/4
			KS-3250	32,0	36,0	1,26	1,42	RR17RK9/50	50	1,969	TK32	260	10,236	TKK32	175	6,890	3/4
			KS-3260	32,0	36,0	1,26	1,42	RR17RK9/60	60	2,362	TK32	260	10,236	TKK32	175	6,890	3/4
			KS-3280	32,0	36,0	1,26	1,42	RR17RK9/80	80	3,150	TK32	260	10,236	TKK32	175	6,890	3/4
1-1/2"	38,10	13-20	KS-3342	33,0	38,0	1,30	1,50	RP33RR33/42	42	1,654	TK33	290	11,417	TKK33	181	7,126	3/4
			KS-3350	33,0	38,0	1,30	1,50	RP33RR33/50	50	1,969	TK33	290	11,417	TKK33	181	7,126	3/4
			KS-3360	33,0	38,0	1,30	1,50	RP33RR33/60	60	2,362	TK33	290	11,417	TKK33	181	7,126	3/4
			KS-3380	33,0	38,0	1,30	1,50	RP33RR33/80	80	3,150	TK33	290	11,417	TKK33	181	7,126	3/4
1-3/4"	44,45	8-9	KS-3542	35,0	41,0	1,38	1,61	RR21RK35 /42	42	1,654	TK37	310	12,205	TKK37	188	7,402	3/4
			KS-3550	35,0	41,0	1,38	1,61	RR21RK35 /50	50	1,969	TK37	310	12,205	TKK37	188	7,402	3/4
			KS-3560	35,0	41,0	1,38	1,61	RR21RK35 /60	60	2,362	TK37	310	12,205	TKK37	188	7,402	3/4
			KS-3580	35,0	41,0	1,38	1,61	RR21RK35 /80	80	3,150	TK37	310	12,205	TKK37	188	7,402	3/4
1-3/4"	44,45	10-12	KS-3742	37,0	43,0	1,46	1,69	RR22RK10/42	42	1,654	TK37	310	12,205	TKK37	188	7,402	3/4
			KS-3750	37,0	43,0	1,46	1,69	RR22RK10/50	50	1,969	TK37	310	12,205	TKK37	188	7,402	3/4
			KS-3760	37,0	43,0	1,46	1,69	RR22RK10/60	60	2,362	TK37	310	12,205	TKK37	188	7,402	3/4
			KS-3780	37,0	43,0	1,46	1,69	RR22RK10/80	80	3,150	TK37	310	12,205	TKK37	188	7,402	3/4

KS Series

Tube OD		Tube Gauge	Tool No.	Expansion Range				Rolls				Mandrel			Short Mandrell Set (3 pcs.)			Square
[inch]	[mm]			[mm]		[inch]		No.	Lenght		No.	Length		No.	Length			
		[BWG]	min	max	min	max			[mm]	[inch]			[mm]		[inch]		[mm]	[inch]
1-3/4"	44,45	12-18	KS-3942	39,0	45,0	1,54	1,77	RR40RK40/42	42	1,654	TK37	310	12,205	TKK37	188	7,402	3/4	
			KS-3950	39,0	45,0	1,54	1,77	RR40RK40/50	50	1,969	TK37	310	12,205	TKK37	188	7,402	3/4	
			KS-3960	39,0	45,0	1,54	1,77	RR40RK40/60	60	2,362	TK37	310	12,205	TKK37	188	7,402	3/4	
			KS-3980	39,0	45,0	1,54	1,77	RR40RK40/80	80	3,150	TK37	310	12,205	TKK37	188	7,402	3/4	
2"	50,80	7-9	KS-4040	40,0	46,0	1,57	1,81	RR40RK40/40	40	1,575	TK42	310	12,205	TKK42	205	8,071	3/4	
			KS-4050	40,0	46,0	1,57	1,81	RR40RK40/50	50	1,969	TK42	310	12,205	TKK42	205	8,071	3/4	
			KS-4060	40,0	46,0	1,57	1,81	RR40RK40/60	60	2,362	TK42	310	12,205	TKK42	205	8,071	3/4	
			KS-4080	40,0	46,0	1,57	1,81	RR40RK40/80	80	3,150	TK42	310	12,205	TKK42	205	8,071	3/4	
2"	50,80	10-13	KS-4240	42,0	48,0	1,65	1,89	RR23RK11/40	40	1,575	TK42	310	12,205	TKK42	205	8,071	3/4	
			KS-4250	42,0	48,0	1,65	1,89	RR23RK11/50	50	1,969	TK42	310	12,205	TKK42	205	8,071	3/4	
			KS-4260	42,0	48,0	1,65	1,89	RR23RK11/60	60	2,362	TK42	310	12,205	TKK42	205	8,071	3/4	
			KS-4280	42,0	48,0	1,65	1,89	RR23RK11/80	80	3,150	TK42	310	12,205	TKK42	205	8,071	3/4	
2"	50,80	12-14	KS-4440	44,0	50,0	1,73	1,97	RR23RK11/40	40	1,575	TK44	310	12,205	TKK44	205	8,071	3/4	
			KS-4450	44,0	50,0	1,73	1,97	RR23RK11/50	50	1,969	TK44	310	12,205	TKK44	205	8,071	3/4	
			KS-4460	44,0	50,0	1,73	1,97	RR23RK11/60	60	2,362	TK44	310	12,205	TKK44	205	8,071	3/4	
			KS-4480	44,0	50,0	1,73	1,97	RR23RK11/80	80	3,150	TK44	310	12,205	TKK44	205	8,071	3/4	
2"	50,80	15-16	KS-4740	47,0	54,0	1,85	2,13	RR24RK12/40	40	1,575	TK47	340	13,307	TKK47	218	8,583	3/4	
			KS-4750	47,0	54,0	1,85	2,13	RR24RK12/50	50	1,969	TK47	340	13,307	TKK47	218	8,583	3/4	
			KS-4760	47,0	54,0	1,85	2,13	RR24RK12/60	60	2,362	TK47	340	13,307	TKK47	218	8,583	3/4	
			KS-4780	47,0	54,0	1,85	2,13	RR24RK12/80	80	3,150	TK47	340	13,307	TKK47	218	8,583	3/4	
2-1/4"	57,15	10-13	KS-4940	49,0	56,0	1,93	2,20	RR24RK12/40	40	1,575	TK49	340	13,307	TKK49	218	8,583	3/4	
			KS-4950	49,0	56,0	1,93	2,20	RR24RK12/50	50	1,969	TK49	340	13,307	TKK49	218	8,583	3/4	
			KS-4960	49,0	56,0	1,93	2,20	RR24RK12/60	60	2,362	TK49	340	13,307	TKK49	218	8,583	3/4	
			KS-4980	49,0	56,0	1,93	2,20	RR24RK12/80	80	3,150	TK49	340	13,307	TKK49	218	8,583	3/4	
2-1/4"	57,15	14-16	KS-5240	52,0	59,0	2,05	2,32	RR25RK13/40	40	1,575	TK49	340	13,307	TKK49	218	8,583	3/4	
			KS-5250	52,0	59,0	2,05	2,32	RR25RK13/50	50	1,969	TK49	340	13,307	TKK49	218	8,583	3/4	
			KS-5260	52,0	59,0	2,05	2,32	RR25RK13/60	60	2,362	TK49	340	13,307	TKK49	218	8,583	3/4	
			KS-5280	52,0	59,0	2,05	2,32	RR25RK13/80	80	3,150	TK49	340	13,307	TKK49	218	8,583	3/4	
2-1/2"	63,50	8-13	KS-5440	54,0	62,0	2,13	2,44	RR26RK14/40	40	1,575	TK54	375	14,764	TKK54	230	9,055	3/4	
			KS-5450	54,0	62,0	2,13	2,44	RR26RK14/50	50	1,969	TK54	375	14,764	TKK54	230	9,055	3/4	
			KS-5460	54,0	62,0	2,13	2,44	RR26RK14/60	60	2,362	TK54	375	14,764	TKK54	230	9,055	3/4	
			KS-5480	54,0	62,0	2,13	2,44	RR26RK14/80	80	3,150	TK54	375	14,764	TKK54	230	9,055	3/4	
2-1/2"	63,50	12-16	KS-5740	57,0	66,0	2,24	2,60	RR27RK15/40	40	1,575	TK57	395	15,551	TKK57	235	9,252	3/4	
			KS-5750	57,0	66,0	2,24	2,60	RR27RK15/50	50	1,969	TK57	395	15,551	TKK57	235	9,252	3/4	
			KS-5760	57,0	66,0	2,24	2,60	RR27RK15/60	60	2,362	TK57	395	15,551	TKK57	235	9,252	3/4	
			KS-5780	57,0	66,0	2,24	2,60	RR27RK15/80	80	3,150	TK57	395	15,551	TKK57	235	9,252	3/4	
2-3/4"	69,85	7-11	KS-6040	60,0	69,0	2,36	2,72	RR28RK16/40	40	1,575	TK57	395	15,551	TKK57	235	9,252	3/4	
			KS-6050	60,0	69,0	2,36	2,72	RR28RK16/50	50	1,969	TK57	395	15,551	TKK57	235	9,252	3/4	
			KS-6060	60,0	69,0	2,36	2,72	RR28RK16/60	60	2,362	TK57	395	15,551	TKK57	235	9,252	3/4	
			KS-6080	60,0	69,0	2,36	2,72	RR28RK16/80	80	3,150	TK57	395	15,551	TKK57	235	9,252	3/4	
3"	76,20	7-8	KS-6540	65,0	74,0	2,56	2,91	RR29RK17/40	40	1,575	TK65	395	15,551	TKK65	235	9,252	3/4	
			KS-6550	65,0	74,0	2,56	2,91	RR29RK17/50	50	1,969	TK65	395	15,551	TKK65	235	9,252	3/4	
			KS-6560	65,0	74,0	2,56	2,91	RR29RK17/60	60	2,362	TK65	395	15,551	TKK65	235	9,252	3/4	
			KS-6580	65,0	74,0	2,56	2,91	RR29RK17/80	80	3,150	TK65	395	15,551	TKK65	235	9,252	3/4	
3"	76,20	10-14	KS-6840	68,0	77,0	2,68	3,03	RR30RK18/40	40	1,575	TK72	403	15,866	TKK72	255	10,039	1	
			KS-6850	68,0	77,0	2,68	3,03	RR30RK18/50	50	1,969	TK72	403	15,866	TKK72	255	10,039	1	
			KS-6860	68,0	77,0	2,68	3,03	RR30RK18/60	60	2,362	TK72	403	15,866	TKK72	255	10,039	1	
			KS-6880	68,0	77,0	2,68	3,03	RR30RK18/80	80	3,150	TK72	403	15,866	TKK72	255	10,039	1	
3-1/4"	82,55	7-11	KS-7240	72,0	81,0	2,83	3,19	RR31RK19/40	40	1,575	TK72	403	15,866	TKK72	255	10,039	1	
			KS-7250	72,0	81,0	2,83	3,19	RR31RK19/50	50	1,969	TK72	403	15,866	TKK72	255	10,039	1	
			KS-7260	72,0	81,0	2,83	3,19	RR31RK19/60	60	2,362	TK72	403	15,866	TKK72	255	10,039	1	
			KS-7280	72,0	81,0	2,83	3,19	RR31RK19/80	80	3,150	TK72	403	15,866	TKK72	255	10,039	1	
3-1/4"	82,55	15-16	KS-7740	77,0	87,0	3,03	3,43	RR32RK20/40	40	1,575	TK77	422	16,614	TKK77	255	10,039	1	
			KS-7750	77,0	87,0	3,03	3,43	RR32RK20/50	50	1,969	TK77	422	16,614	TKK77	255	10,039	1	
			KS-7760	77,0	87,0	3,03	3,43	RR32RK20/60	60	2,362	TK77	422	16,614	TKK77	255	10,039	1	
			KS-7780	77,0	87,0	3,03	3,43	RR32RK20/80	80	3,150	TK77	422	16,614	TKK77	255	10,039	1	

Tube OD		Tube Gauge	Tool No.	Expansion Range				Rolls			Mandrel			Short Mandrell Set (3 pcs.)			Square
[inch]	[mm]			[mm]		[inch]		No.	Lenght		No.	Length		No.	Length		
		[BWG]	min	max	min	max			[mm]	[inch]			[mm]		[inch]		[mm]
3-1/2"	88,90	10-13	KS-8240	82,0	92,0	3,23	3,62	RR33RK21/40	40	1,575	TK82	422	16,614	TKK82	255	10,039	1
			KS-8250	82,0	92,0	3,23	3,62	RR33RK21/50	50	1,969	TK82	422	16,614	TKK82	255	10,039	1
			KS-8260	82,0	92,0	3,23	3,62	RR33RK21/60	60	2,362	TK82	422	16,614	TKK82	255	10,039	1
			KS-8280	82,0	92,0	3,23	3,62	RR33RK21/80	80	3,150	TK82	422	16,614	TKK82	255	10,039	1
3-3/4"	95,25	8-12	KS-8640	86,0	96,0	3,39	3,78	RR34RK22/40	40	1,575	TK86	422	16,614	TKK86	255	10,039	1
			KS-8650	86,0	96,0	3,39	3,78	RR34RK22/50	50	1,969	TK86	422	16,614	TKK86	255	10,039	1
			KS-8660	86,0	96,0	3,39	3,78	RR34RK22/60	60	2,362	TK86	422	16,614	TKK86	255	10,039	1
			KS-8680	86,0	96,0	3,39	3,78	RR34RK22/80	80	3,150	TK86	422	16,614	TKK86	255	10,039	1
4"	101,60	9-12	KS-9040	90,0	100,0	3,54	3,94	RR34RK22/40	40	1,575	TK90	422	16,614	TKK90	275	10,827	1
			KS-9050	90,0	100,0	3,54	3,94	RR34RK22/50	50	1,969	TK90	422	16,614	TKK90	275	10,827	1
			KS-9060	90,0	100,0	3,54	3,94	RR34RK22/60	60	2,362	TK90	422	16,614	TKK90	275	10,827	1
			KS-9080	90,0	100,0	3,54	3,94	RR34RK22/80	80	3,150	TK90	422	16,614	TKK90	275	10,827	1
4"	101,60	16	KS-9640	96,0	106,0	3,78	4,17	RR35RK23/40	40	1,575	TK96	422	16,614	TKK96	275	10,827	1
			KS-9650	96,0	106,0	3,78	4,17	RR35RK23/50	50	1,969	TK96	422	16,614	TKK96	275	10,827	1
			KS-9660	96,0	106,0	3,78	4,17	RR35RK23/60	60	2,362	TK96	422	16,614	TKK96	275	10,827	1
			KS-9680	96,0	106,0	3,78	4,17	RR35RK23/80	80	3,150	TK96	422	16,614	TKK96	275	10,827	1

* 100 mm roll length made to order only if technically possible

PZ Series

The PZ expanders come equipped with three expansion rolls and a self-feeding mechanism, making them perfect for both re-rolling leaky tubes and constructing new water tube boilers, fire tube boilers, economizers, and air heaters. Upon request, these expanders are available with five rolls for more demanding applications. KRAIS K70 right-angle rolling motors are recommended for use with these expanders.



ADDITIONAL INFORMATION



How-to basics
→ PAGE 32



Rolls range
→ PAGE 33



Rolling motors
→ PAGE 45

Tube OD		Tube Gauge	Tool No.	Expansion Range				Standard Rolls			Mandrel		Short Mandrell Set (3 pcs.)			Square	
[inch]	[mm]	[BWG]		[mm]		[inch]		No.	Length		No.	Length		No.	Length		
			min	max	min	max	[mm]		[inch]	[mm]		[inch]	[mm]		[inch]	[mm]	[inch]
1"	25,40	11-12	PZ-1942	19,0	22,0	0,75	0,87	RR12/42	42	1,654	TK19	196	7,677	-	-	-	1/2
			PZ-1950	19,0	22,0	0,75	0,87	RR12/50	50	1,969	TK19	196	7,677	-	-	-	1/2
1"	25,40	13-16	PZ-2042	20,0	23,0	0,79	0,91	RR12/42	42	1,654	TK20	196	8,189	-	-	-	1/2
			PZ-2050	20,0	23,0	0,79	0,91	RR12/50	50	1,969	TK20	196	8,189	-	-	-	1/2
1-1/8"	28,58	12-14	PZ-2242	22,0	25,0	0,87	0,98	RR12/42	42	1,654	TK22	196	8,661	-	-	-	1/2
			PZ-2250	22,0	25,0	0,87	0,98	RR12/50	50	1,969	TK22	196	8,661	-	-	-	1/2
1-1/8"	28,58	14-16	PZ-2342	23,0	26,0	0,91	1,02	RR13/42	42	1,654	TK23	196	8,661	-	-	-	1/2
			PZ-2350	23,0	26,0	0,91	1,02	RR13/50	50	1,969	TK23	196	8,661	-	-	-	1/2
1-1/8"	28,58	15-17	PZ-2442	24,0	27,0	0,94	1,06	RR13/42	42	1,654	TK24	196	8,661	-	-	-	1/2
			PZ-2450	24,0	27,0	0,94	1,06	RR13/50	50	1,969	TK24	196	8,661	-	-	-	1/2
1-1/8"	28,58	16	PZ-2542	25,0	28,0	0,98	1,10	RR13/42	42	1,654	TK25	196	8,661	-	-	-	1/2
			PZ-2550	25,0	28,0	0,98	1,10	RR13/50	50	1,969	TK25	196	8,661	-	-	-	1/2
1-1/4"	31,75	12-14	PZ-2642	26,0	29,0	1,02	1,14	RR13/42	42	1,654	TK26	196	8,661	-	-	-	1/2
			PZ-2650	26,0	29,0	1,02	1,14	RR13/50	50	1,969	TK26	196	8,661	-	-	-	1/2
1-1/4"	31,75	12-17	PZ-2742	27,0	30,0	1,06	1,18	RR15/42	42	1,654	TK27	196	8,661	-	-	-	1/2
			PZ-2750	27,0	30,0	1,06	1,18	RR15/50	50	1,969	TK27	196	8,661	-	-	-	1/2
1-1/4"	31,75	16	PZ-2842	28,0	32,0	1,10	1,26	RR16/42	42	1,654	TK28	260	11,220	-	-	-	3/4
			PZ-2850	28,0	32,0	1,10	1,26	RR16/50	50	1,969	TK28	260	11,220	-	-	-	3/4
1-1/2"	38,10	7-11	PZ-2942	29,0	33,0	1,14	1,30	RR16/42	42	1,654	TK29	260	11,220	-	-	-	3/4
			PZ-2950	29,0	33,0	1,14	1,30	RR16/50	50	1,969	TK29	260	11,220	-	-	-	3/4
1-1/2"	38,10	10-12	PZ-3042	30,0	34,0	1,18	1,34	RR16/42	42	1,654	TK30	260	11,220	-	-	-	3/4
			PZ-3050	30,0	34,0	1,18	1,34	RR16/50	50	1,969	TK30	260	11,220	-	-	-	3/4
1-1/2"	38,10	13-16	PZ-3242	32,0	36,0	1,26	1,42	RR17/42	42	1,654	TK32	260	10,236	-	-	-	3/4
			PZ-3250	32,0	36,0	1,26	1,42	RR17/50	50	1,969	TK32	260	10,236	-	-	-	3/4
1-1/2"	38,10	13-20	PZ-3342	33,0	38,0	1,30	1,50	RP33/42	42	1,654	TK33	290	11,417	TKK33	181,00	7,126	3/4
			PZ-3350	33,0	38,0	1,30	1,50	RP33/50	50	1,969	TK33	290	11,417	TKK33	181,00	7,126	3/4
1-3/4"	44,45	8-9	PZ-3542	35,0	41,0	1,38	1,61	RR21/42	42	1,654	TK37	310	12,205	TKK37	188,00	7,402	3/4
			PZ-3550	35,0	41,0	1,38	1,61	RR21/50	50	1,969	TK37	310	12,205	TKK37	188,00	7,402	3/4
1-3/4"	44,45	10-16	PZ-3742	37,0	43,0	1,46	1,69	RR22/42	42	1,654	TK37	310	12,205	TKK37	188,00	7,402	3/4
			PZ-3750	37,0	43,0	1,46	1,69	RR22/50	50	1,969	TK37	310	12,205	TKK37	188,00	7,402	3/4
1-3/4"	44,45	12-18	PZ-3942	39,0	45,0	1,54	1,77	RR40/42	42	1,654	TK37	310	12,205	TKK37	188,00	7,402	3/4
			PZ-3950	39,0	45,0	1,54	1,77	RR40/50	50	1,969	TK37	310	12,205	TKK37	188,00	7,402	3/4
2"	50,80	7-10	PZ-4050	40,0	46,0	1,57	1,81	RR40/50	50	1,969	TK42	310	12,205	TKK42	205,00	8,071	3/4
			PZ-4080	40,0	46,0	1,57	1,81	RR40/80	80	3,150	TK42	310	12,205	TKK42	205,00	8,071	3/4

PZ Series

Tube OD		Tube Gauge	Tool No.	Expansion Range				Standard Rolls			Mandrel			Short Mandrel Set (3 pcs.)			Square
[inch]	[mm]			[mm]		[inch]		No.	Length		No.	Length		No.	Length		
		[BWG]	min	max	min	max			[mm]	[inch]			[mm]		[inch]		[mm]
2"	50,80	11-12	PZ-4250	42,0	48,0	1,65	1,89	RR23/50	50	1,969	TK42	310	12,205	TKK42	205,00	8,071	3/4
			PZ-4280	42,0	48,0	1,65	1,89	RR23/80	80	3,150	TK42	310	12,205	TKK42	205,00	8,071	3/4
2"	50,80	13-15	PZ-4450	44,0	50,0	1,73	1,97	RR23/50	50	1,969	TK44	310	12,205	TKK44	205,00	8,071	3/4
			PZ-4480	44,0	50,0	1,73	1,97	RR23/80	80	3,150	TK44	310	12,205	TKK44	205,00	8,071	3/4
2"	50,80	15-16	PZ-4750	47,0	54,0	1,85	2,13	RR24/50	50	1,969	TK47	340	13,307	TKK47	218,00	8,583	3/4
			PZ-4780	47,0	54,0	1,85	2,13	RR24/80	80	3,150	TK47	340	13,307	TKK47	218,00	8,583	3/4
2-1/4"	57,15	10-12	PZ-4950	49,0	56,0	1,93	2,20	RR24/50	50	1,969	TK49	340	13,307	TKK49	218,00	8,583	3/4
			PZ-4980	49,0	56,0	1,93	2,20	RR24/80	80	3,150	TK49	340	13,307	TKK49	218,00	8,583	3/4
2-1/4"	57,15	14-16	PZ-5250	52,0	59,0	2,05	2,32	RR25/50	50	1,969	TK49	340	13,307	TKK49	218,00	8,583	3/4
			PZ-5280	52,0	59,0	2,05	2,32	RR25/80	80	3,150	TK49	340	13,307	TKK49	218,00	8,583	3/4
2-1/2"	63,50	11-12	PZ-5450	54,0	62,0	2,13	2,44	RR26/50	50	1,969	TK54	375	14,764	TKK54	230,00	9,055	3/4
			PZ-5480	54,0	62,0	2,13	2,44	RR26/80	80	3,150	TK54	375	14,764	TKK54	230,00	9,055	3/4
2-1/2"	63,50	13-16	PZ-5750	57,0	66,0	2,24	2,60	RR27/50	50	1,969	TK57	395	15,551	TKK57	235,00	9,252	3/4
			PZ-5780	57,0	66,0	2,24	2,60	RR27/80	80	3,150	TK57	395	15,551	TKK57	235,00	9,252	3/4
2-3/4"	69,85	7-11	PZ-6050	60,0	69,0	2,36	2,72	RR28/50	50	1,969	TK57	395	15,551	TKK57	235,00	9,252	3/4
			PZ-6080	60,0	69,0	2,36	2,72	RR28/80	80	3,150	TK57	395	15,551	TKK57	235,00	9,252	3/4
3"	76,20	7-11	PZ-6550	65,0	74,0	2,56	2,91	RR29/50	50	1,969	TK65	395	15,551	TKK65	235,00	9,252	3/4
			PZ-6580	65,0	74,0	2,56	2,91	RR29/80	80	3,150	TK65	395	15,551	TKK65	235,00	9,252	3/4
3"	76,20	12-13	PZ-6850	68,0	77,0	2,68	3,03	RR30/50	50	1,969	TK72	403	15,866	TKK72	255,00	10,039	1
			PZ-6880	68,0	77,0	2,68	3,03	RR30/80	80	3,150	TK72	403	15,866	TKK72	255,00	10,039	1
3-1/4"	82,55	7-12	PZ-7250	72,0	81,0	2,83	3,19	RR31/50	50	1,969	TK72	403	15,866	TKK72	255,00	10,039	1
			PZ-7280	72,0	81,0	2,83	3,19	RR31/80	80	3,150	TK72	403	15,866	TKK72	255,00	10,039	1
3-1/4"	82,55	13-16	PZ-7750	77,0	87,0	3,03	3,43	RR32/50	50	1,969	TK77	422	16,614	TKK77	255,00	10,039	1
			PZ-7780	77,0	87,0	3,03	3,43	RR32/80	80	3,150	TK77	422	16,614	TKK77	255,00	10,039	1
3-1/2"	88,90	10-16	PZ-8250	82,0	92,0	3,23	3,62	RR33/50	50	1,969	TK82	422	16,614	TKK82	255,00	10,039	1
			PZ-8280	82,0	92,0	3,23	3,62	RR33/80	80	3,150	TK82	422	16,614	TKK82	255,00	10,039	1
3-3/4"	95,25	7-12	PZ-8650	86,0	96,0	3,39	3,78	RR34/50	50	1,969	TK86	422	16,614	TKK86	255,00	10,039	1
			PZ-8680	86,0	96,0	3,39	3,78	RR34/80	80	3,150	TK86	422	16,614	TKK86	255,00	10,039	1
4"	101,60	8-12	PZ-9050	90,0	100,0	3,54	3,94	RR34/50	50	1,969	TK90	422	16,614	TKK90	275,00	10,827	1
			PZ-9080	90,0	100,0	3,54	3,94	RR34/80	80	3,150	TK90	422	16,614	TKK90	275,00	10,827	1
4"	101,60	13-16	PZ-9650	96,0	106,0	3,78	4,17	RR35/50	50	1,969	TK96	422	16,614	TKK96	275,00	10,827	1
			PZ-9680	96,0	106,0	3,78	4,17	RR35/80	80	3,150	TK96	422	16,614	TKK96	275,00	10,827	1

* 100 mm roll length made to order, only if technically possible!

SHORTER EXPANSION LENGTH



If you require expanding shorter expansion length than a standard expander, we can supply the reduction collar SC (you can specify desired length in order e.g. PZ-4280/60).

FTKS-L Flare Type Series

The FTKS-L expander stands out for its self-feeding mechanism that combines three expansion rolls and three flare rolls, allowing for simultaneous tube expansion and flaring. An adjustable thrust collar ensures friction-free operation, longer tool life, and consistent flare length. This expander is highly effective for re-rolling leaky tubes and new installations in water tube boilers, fire tube boilers, economizers, and air heaters. KRAIS K70 right-angle rolling motors are recommended for use with this tool.



ADDITIONAL INFORMATION



How-to basics
→ PAGE 32



Rolls range
→ PAGE 33



Rolling motors
→ PAGE 45

Tube OD		Tube Gauge	Tool No.	Expansion Range				Standard Rolls				Mandrel			Short Mandrell Set (3 pcs.)			Square
[inch]	[mm]			[mm]		[inch]		No.	Length		No.	Length		No.	Length			
				min	max	min	max		[mm]	[inch]		[mm]	[inch]		[mm]	[inch]	[inch]	
1-1/4"	31,75	16	FTKS-2842-L	28,0	31,5	1,10	1,24	RR16RK8	42	1,654	T-300	375	14,764	PTK28	175	6,890	3/4	
			FTKS-2880-L	28,0	31,5	1,10	1,24	RR16RK8/80	80	3,150	T-300	375	14,764	PTK28	175	6,890	3/4	
1-1/2"	38,10	7-10	FTKS-2942-L	29,0	32,5	1,14	1,28	RR16RK8	42	1,654	T-300	375	14,764	PTK29	175	6,890	3/4	
			FTKS-2980-L	29,0	32,5	1,14	1,28	RR16RK8/80	80	3,150	T-300	375	14,764	PTK29	175	6,890	3/4	
1-1/2"	38,10	10-12	FTKS-3042-L	30,0	33,5	1,18	1,32	RR16RK8	42	1,654	T-300	375	14,764	PTK30	175	6,890	3/4	
			FTKS-3080-L	30,0	33,5	1,18	1,32	RR16RK8/80	80	3,150	T-300	375	14,764	PTK30	175	6,890	3/4	
1-1/2"	38,10	12-14	FTKS-3242-L	32,0	35,5	1,26	1,40	RR17RK9	42	1,654	T-320	385	15,157	PTK32	175	6,890	3/4	
			FTKS-3280-L	32,0	35,5	1,26	1,40	RR17RK9/80	80	3,150	T-320	385	15,157	PTK32	175	6,890	3/4	
1-1/2"	38,10	13-20	FTKS-3342-L	33,0	36,5	1,30	1,44	RP33RR33	42	1,654	T-320	385	15,157	PTK33	181	7,126	3/4	
			FTKS-3380-L	33,0	36,5	1,30	1,44	RP33RR33/80	80	3,150	T-320	385	15,157	PTK33	181	7,126	3/4	
1-3/4"	44,45	8-9	FTKS-3542-L	35,0	40,5	1,38	1,59	RR21RK35	42	1,654	T-370	410	16,142	PTK37	188	7,402	3/4	
			FTKS-3580-L	35,0	40,5	1,38	1,59	RR21RK35/80	80	3,150	T-370	410	16,142	PTK37	188	7,402	3/4	
1-3/4"	44,45	10-12	FTKS-3742-L	37,0	42,5	1,46	1,67	RR22RK10	42	1,654	T-370	410	16,142	PTK37	188	7,402	3/4	
			FTKS-3780-L	37,0	42,5	1,46	1,67	RR22RK10/80	80	3,150	T-370	410	16,142	PTK37	188	7,402	3/4	
1-3/4"	44,45	12-18	FTKS-3950-L	39,0	44,5	1,54	1,75	RR40RK40	50	1,969	T-370	410	16,142	PTK37	188	7,402	3/4	
			FTKS-3980-L	39,0	44,5	1,54	1,75	RR40RK40/80	80	3,150	T-370	410	16,142	PTK37	188	7,402	3/4	
2"	50,80	7-9	FTKS-4050-L	40,0	45,5	1,57	1,79	RR40RK40	50	1,969	T-420	410	16,142	PTK42	205	8,071	3/4	
			FTKS-4080-L	40,0	45,5	1,57	1,79	RR40RK40/80	80	3,150	T-420	410	16,142	PTK42	205	8,071	3/4	
2"	50,80	10-13	FTKS-4250-L	42,0	47,5	1,65	1,87	RR23RK11	50	1,969	T-420	410	16,142	PTK42	205	8,071	3/4	
			FTKS-4280-L	42,0	47,5	1,65	1,87	RR23RK11/80	80	3,150	T-420	410	16,142	PTK42	205	8,071	3/4	
2"	50,80	12-14	FTKS-4450-L	44,0	49,5	1,73	1,95	RR23RK11	50	1,969	T-440	410	16,142	PTK44	205	8,071	3/4	
			FTKS-4480-L	44,0	49,5	1,73	1,95	RR23RK11/80	80	3,150	T-440	410	16,142	PTK44	205	8,071	3/4	
2"	50,80	16	FTKS-4750-L	47,0	53,5	1,85	2,11	RR24RK12	50	1,969	T-470	435	17,126	PTK47	218	8,583	3/4	
			FTKS-4780-L	47,0	53,5	1,85	2,11	RR24RK12/80	80	3,150	T-470	435	17,126	PTK47	218	8,583	3/4	
2-1/4"	57,15	10-13	FTKS-4950-L	49,0	55,5	1,93	2,19	RR24RK12	50	1,969	T-490	435	17,126	PTK49	218	8,583	3/4	
			FTKS-4980-L	49,0	55,5	1,93	2,19	RR24RK12/80	80	3,150	T-490	435	17,126	PTK49	218	8,583	3/4	
2-1/4"	57,15	14-16	FTKS-5250-L	52,0	58,5	2,05	2,30	RR25RK13	50	1,969	T-490	435	17,126	PTK49	218	8,583	3/4	
			FTKS-5280-L	52,0	58,5	2,05	2,30	RR25RK13/80	80	3,150	T-490	435	17,126	PTK49	218	8,583	3/4	
2-1/2"	63,50	8-13	FTKS-5450-L	54,0	61,5	2,13	2,42	RR26RK14	50	1,969	T-540	470	18,504	PTK54	230	9,055	3/4	
			FTKS-5480-L	54,0	61,5	2,13	2,42	RR26RK14/80	80	3,150	T-540	470	18,504	PTK54	230	9,055	3/4	

Tube OD		Tube Gauge	Tool No.	Expansion Range				Standard Rolls			Mandrel		Short Mandrell Set (3 pcs.)			Square	
[inch]	[mm]			[mm]		[inch]		No.	Length		No.	Length		No.	Length		
		[BWG]		min	max	min	max		[mm]	[inch]		[mm]	[inch]		[mm]	[inch]	[inch]
2-1/2"	63,50	12-16	FTKS-5750-L	57,0	65,5	2,24	2,58	RR27RK15	50	1,969	T-570	500	19,685	PTK57	235	9,252	3/4
			FTKS-5780-L	57,0	65,5	2,24	2,58	RR27RK15/80	80	3,150	T-570	500	19,685	PTK57	235	9,252	3/4
2-3/4"	69,85	7-11	FTKS-6050-L	60,0	68,5	2,36	2,70	RR28RK16	50	1,969	T-570	500	19,685	PTK57	235	9,252	3/4
			FTKS-6080-L	60,0	68,5	2,36	2,70	RR28RK16/80	80	3,150	T-570	500	19,685	PTK57	235	9,252	3/4
3"	76,20	7-8	FTKS-6550-L	65,0	73,5	2,56	2,89	RR29RK17	50	1,969	T-650	500	19,685	PTK65	235	9,252	3/4
			FTKS-6580-L	65,0	73,5	2,56	2,89	RR29RK17/80	80	3,150	T-650	500	19,685	PTK65	235	9,252	3/4
3"	76,20	10-14	FTKS-6850-L	68,0	76,5	2,68	3,01	RR30RK18	50	1,969	T-720	530	20,866	PTK72	255	10,039	1
			FTKS-6880-L	68,0	76,5	2,68	3,01	RR30RK18/80	80	3,150	T-720	530	20,866	PTK72	255	10,039	1
3-1/4"	82,55	7-11	FTKS-7250-L	72,0	80,5	2,83	3,17	RR31RK19	50	1,969	T-720	530	20,866	PTK72	255	10,039	1
			FTKS-7280-L	72,0	80,5	2,83	3,17	RR31RK19/80	80	3,150	T-720	530	20,866	PTK72	255	10,039	1
3-1/4"	82,55	15-16	FTKS-7750-L	77,0	86,5	3,03	3,41	RR32RK20	50	1,969	T-770	530	20,866	PTK77	255	10,039	1
			FTKS-7780-L	77,0	86,5	3,03	3,41	RR32RK20/80	80	3,150	T-770	530	20,866	PTK77	255	10,039	1
3-1/2"	88,90	10-13	FTKS-8250-L	82,0	91,5	3,23	3,60	RR33RK21	50	1,969	T-820	530	20,866	PTK82	255	10,039	1
			FTKS-8280-L	82,0	91,5	3,23	3,60	RR33RK21/80	80	3,150	T-820	530	20,866	PTK82	255	10,039	1
3-3/4"	95,25	8-12	FTKS-8650-L	86,0	95,5	3,39	3,76	RR34RK22	50	1,969	T-860	530	20,866	PTK86	255	10,039	1
			FTKS-8680-L	86,0	95,5	3,39	3,76	RR34RK22/80	80	3,150	T-860	530	20,866	PTK86	255	10,039	1
4"	101,60	9-12	FTKS-9050-L	90,0	99,5	3,54	3,92	RR34RK22	50	1,969	T-900	530	20,866	PTK90	275	10,827	1
			FTKS-9080-L	90,0	99,5	3,54	3,92	RR34RK22/80	80	3,150	T-900	530	20,866	PTK90	275	10,827	1
4"	101,60	16	FTKS-9650-L	96,0	105,5	3,78	4,15	RR35RK23	50	1,969	T-960	530	20,866	PTK96	275	10,827	1
			FTKS-9680-L	96,0	105,5	3,78	4,15	RR35RK23/80	80	3,150	T-960	530	20,866	PTK96	275	10,827	1

P2 Series

The P2 expander is designed for deep-reach tube expansions with its three rolls and adjustable reach. It offers parallel rolling with long, effective double-radius rolls, which are self-retained in the cage. This expander is excellent for touch-up expansion, hard rolling, re-rolling leaky tubes, and new constructions in water tube boilers, fire tube boilers, economizers, and air heaters. Expanders with five rolls, longer rolls, or extended reach in 2-inch increments are available upon request. KRAIS K70 right-angle rolling motors are recommended for use with these expanders.



ADDITIONAL INFORMATION



How-to basics
→ PAGE 32



Rolls range
→ PAGE 33



Rolling motors
→ PAGE 45

MAX REACH FOR P2 EXPANDERS

COLLAR	60 MM ROLLS		80 MM ROLLS	
	[MM]	[INCH]	[MM]	[INCH]
Standard	112	4,40"	132	5,20"
Short	132	5,20"	152	6"

Tube OD		Tube Gauge	Tool No.	Expansion range				Rolls			Mandrel			Short Mandrell Set (3 pcs.)			Square
[inch]	[mm]	[bwg]		min	max	min	max	No.	Length		No.	Length		No.	Length		
								[mm]	[inch]		[mm]	[inch]		[mm]	[inch]	[inch]	
1-1/4"	31,70	16	P2-280	28,0	33,0	1,10	1,30	998	60	2,362	T-290	385,00	15,157	PTK28	175	6,890	1/2"
			P2-280/80	28,0	33,0	1,10	1,30	998/80	80	3,150	T-290	385,00	15,157	PTK28	175	6,890	1/2"
1-1/2"	38,10	7-11	P2-290	29,0	34,0	1,14	1,34	1048	60	2,362	T-290	385,00	15,157	PTK29	175	6,890	1/2"
			P2-290/80	29,0	34,0	1,14	1,34	1048/80	80	3,150	T-290	385,00	15,157	PTK29	175	6,890	1/2"
1-1/2"	38,10	10-12	P2-300	30,0	35,0	1,18	1,38	1089	60	2,362	T-290	385,00	15,157	PTK30	175	6,890	1/2"
			P2-300/80	30,0	35,0	1,18	1,38	1089/80	80	3,150	T-290	385,00	15,157	PTK30	175	6,890	1/2"
1-1/2"	38,10	13-16	P2-320	32,0	37,0	1,26	1,46	1143	60	2,362	T-320	385,00	15,157	PTK32	175	6,890	1/2"
			P2-320/80	32,0	37,0	1,26	1,46	1143/80	80	3,150	T-320	385,00	15,157	PTK32	175	6,890	1/2"
1-1/2"	38,10	13-20	P2-330	33,0	38,0	1,30	1,50	RR1143	60	2,362	T-320	385,00	15,157	PTK33	181	7,126	3/4"
			P2-330/80	33,0	38,0	1,30	1,50	RR1143/80	80	3,150	T-320	385,00	15,157	PTK33	181	7,126	3/4"
1-3/4"	44,40	8-9	P2-350	35,0	41,0	1,38	1,61	RR21A	60	2,362	T-370	410,00	16,142	PTK37	188	7,402	3/4"
			P2-350/80	35,0	41,0	1,38	1,61	RR21A/80	80	3,150	T-370	410,00	16,142	PTK37	188	7,402	3/4"
1-3/4"	44,40	10-16	P2-370	37,0	43,0	1,46	1,69	RR22A	60	2,362	T-370	410,00	16,142	PTK37	188	7,402	3/4"
			P2-370/80	37,0	43,0	1,46	1,69	RR22A/80	80	3,150	T-370	410,00	16,142	PTK37	188	7,402	3/4"
1-3/4"	44,45	12-18	P2-390	39,0	45,0	1,54	1,77	RR22A	60	2,362	T-370	410,00	16,142	PTK37	188	7,402	3/4"
			P2-390/80	39,0	45,0	1,54	1,77	RR22A/80	80	3,150	T-370	410,00	16,142	PTK37	188	7,402	3/4"
2"	50,80	7-10	P2-400	40,0	46,0	1,57	1,81	RR40A	60	2,362	T-420	410,00	16,142	PTK42	205	8,071	3/4"
			P2-400/80	40,0	46,0	1,57	1,81	RR40A/80	80	3,150	T-420	410,00	16,142	PTK42	205	8,071	3/4"
2"	50,80	11-12	P2-420	42,0	48,0	1,65	1,89	RR23A	60	2,362	T-420	410,00	16,142	PTK42	205	8,071	3/4"
			P2-420/80	42,0	48,0	1,65	1,89	RR23A/80	80	3,150	T-420	410,00	16,142	PTK42	205	8,071	3/4"
2"	50,80	13-15	P2-440	44,0	50,0	1,73	1,97	RR23A	60	2,362	T-440	410,00	16,142	PTK44	205	8,071	3/4"
			P2-440/80	44,0	50,0	1,73	1,97	RR23A/80	80	3,150	T-440	410,00	16,142	PTK44	205	8,071	3/4"
2"	50,80	16	P2-470	47,0	54,0	1,85	2,13	RR24A	60	2,362	T-470	435,00	17,126	PTK47	218	8,583	3/4"
			P2-470/80	47,0	54,0	1,85	2,13	RR24A/80	80	3,150	T-470	435,00	17,126	PTK47	218	8,583	3/4"
2-1/4"	57,10	10-12	P2-490	49,0	56,0	1,93	2,20	RR24A	60	2,362	T-490	435,00	17,126	PTK49	218	8,583	3/4"
			P2-490/80	49,0	56,0	1,93	2,20	RR24A/80	80	3,150	T-490	435,00	17,126	PTK49	218	8,583	3/4"
2-1/4"	57,10	14-16	P2-520	52,0	59,0	2,05	2,32	RR25A	60	2,362	T-490	435,00	17,126	PTK49	218	8,583	3/4"
			P2-520/80	52,0	59,0	2,05	2,32	RR25A/80	80	3,150	T-490	435,00	17,126	PTK49	218	8,583	3/4"
2-1/2"	63,50	11-12	P2-540	54,0	62,0	2,13	2,44	RR26A	60	2,362	T-540	470,00	18,504	PTK54	230	9,055	3/4"
			P2-540/80	54,0	62,0	2,13	2,44	RR26A/80	80	3,150	T-540	470,00	18,504	PTK54	230	9,055	3/4"
2-1/2"	63,50	13-16	P2-570	57,0	66,0	2,24	2,60	RR27A	60	2,362	T-570	500,00	19,685	PTK57	235	9,252	3/4"
			P2-570/80	57,0	66,0	2,24	2,60	RR27A/80	80	3,150	T-570	500,00	19,685	PTK57	235	9,252	3/4"

Tube OD		Tube Gauge	Tool No.	Expansion range				Rolls			Mandrel			Short Mandrell Set (3 pcs.)			Square
[inch]	[mm]	[bwg]		[mm]		[inch]		No.	Lenght		No.	Length		No.	Length		
				min	max	min	max		[mm]	[inch]		[mm]	[inch]		[mm]	[inch]	
2-3/4"	69,80	7-11	P2-600	60,0	69,0	2,36	2,72	RR28A	60	2,362	T-570	500,00	19,685	PTK57	235	9,252	3/4"
			P2-600/80	60,0	69,0	2,36	2,72	RR28A/80	80	3,150	T-570	500,00	19,685	PTK57	235	9,252	3/4"
3"	76,20	7-11	P2-650	65,0	74,0	2,56	2,91	RR29A	60	2,362	T-650	500,00	19,685	PTK65	235	9,252	3/4"
			P2-650/80	65,0	74,0	2,56	2,91	RR29A/80	80	3,150	T-650	500,00	19,685	PTK65	235	9,252	3/4"
3"	76,20	13-15	P2-680	68,0	77,5	2,68	3,05	RR30A	60	2,362	T-720	530,00	20,866	PTK72	255	10,039	1"
			P2-680/80	68,0	77,5	2,68	3,05	RR30A/80	80	3,150	T-720	530,00	20,866	PTK72	255	10,039	1"
3-1/4"	82,55	7-12	P2-720	72,0	81,5	2,83	3,21	RR31A	60	2,362	T-720	530,00	20,866	PTK72	255	10,039	1"
			P2-720/80	72,0	81,5	2,83	3,21	RR31A/80	80	3,150	T-720	530,00	20,866	PTK72	255	10,039	1"
3-1/4"	82,55	13-16	P2-770	77,0	87,0	3,03	3,43	RR32A	60	2,362	T-770	530,00	20,866	PTK77	255	10,039	1"
			P2-770/80	77,0	87,0	3,03	3,43	RR32A/80	80	3,150	T-770	530,00	20,866	PTK77	255	10,039	1"
3-1/2"	88,90	10-16	P2-820	82,0	92,0	3,23	3,62	RR33A	60	2,362	T-820	530,00	20,866	PTK82	255	10,039	1"
			P2-820/80	82,0	92,0	3,23	3,62	RR33A/80	80	3,150	T-820	530,00	20,866	PTK82	255	10,039	1"
3-3/4"	95,25	7-12	P2-860	86,0	96,0	3,39	3,78	RR34A	60	2,362	T-860	530,00	20,866	PTK86	255	10,039	1"
			P2-860/80	86,0	96,0	3,39	3,78	RR34A/80	80	3,150	T-860	530,00	20,866	PTK86	255	10,039	1"
4"	101,60	8-12	P2-900	90,0	100,0	3,54	3,94	RR34A	60	2,362	T-900	530,00	20,866	PTK90	275	10,827	1"
			P2-900/80	90,0	100,0	3,54	3,94	RR34A/80	80	3,150	T-900	530,00	20,866	PTK90	275	10,827	1"
4"	101,60	13-16	P2-960	96,0	106,0	3,78	4,17	RR35A	60	2,362	T-960	530,00	20,866	PTK96	275	10,827	1"
			P2-960/80	96,0	106,0	3,78	4,17	RR35A/80	80	3,150	T-960	530,00	20,866	PTK96	275	10,827	1"

Universal Combination Roller Beading

The UCRB expander is specifically designed for fabricating and maintaining fire tube boilers with tube sizes between 2" and 3" OD. This self-feeding tool not only expands tubes but also forms a uniform bead tightly against the tube sheet. For the best results, a tube projection of 3/16" (5 mm) is recommended.

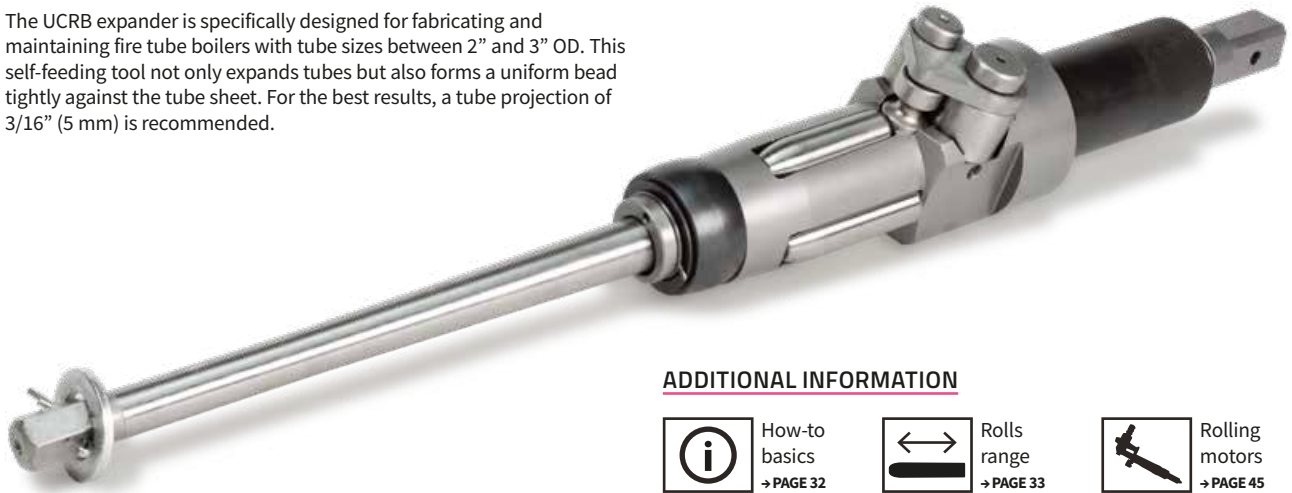

ADDITIONAL INFORMATION



How-to basics
→ PAGE 32



Rolls range
→ PAGE 33



Rolling motors
→ PAGE 45

TUBE OD		TUBE GAUGE	TOOL NO.	EXPANSION RANGE				ROLLS	BEADING ROLLS	FRONT PILOT	MANDREL	SQUARE	
[INCH]	[MM]	[BWG]		[INCH]		[MM]						[INCH]	[MM]
				MIN	MAX	MIN	MAX						
2"	50,8	10	41633-00	1,700	1,907	43,2	48,4	R-42811	BR-41631-10	P-41701-10	M-42157	3/4"	19
		11	41633-00	1,700	1,907	43,2	48,4	R-42811	BR-41631-11	P-41701-11	M-42157	3/4"	19
		12	41633-00	1,700	1,907	43,2	48,4	R-42811	BR-41631-12	P-41701-12	M-42157	3/4"	19
		13	41633-00	1,700	1,907	43,2	48,4	R-42811	BR-41631-13	P-41701-13	M-42157	3/4"	19
2-1/2"	63,5	10	41634-00	2,200	2,460	55,9	62,6	R-41673	BR-41651-10	P-41702-10	M-42158	3/4"	19
		11	41634-00	2,200	2,460	55,9	62,6	R-41673	BR-41651-11	P-41702-11	M-42158	3/4"	19
		12	41634-00	2,200	2,460	55,9	62,6	R-41673	BR-41651-12	P-41702-12	M-42158	3/4"	19
		13	41634-00	2,200	2,460	55,9	62,6	R-41673	BR-41651-13	P-41702-13	M-42158	3/4"	19
3"	76,2	10	41359-00	2,700	2,890	68,6	75,7	R-41676	BR-41666-10	P-41703-10	M-42159	1"	25,4
		11	41359-00	2,700	2,890	68,6	75,7	R-41676	BR-41666-11	P-41703-11	M-42159	1"	25,4
		12	41359-00	2,700	2,890	68,6	75,7	R-41676	BR-41666-12	P-41703-12	M-42159	1"	25,4

RECOMMENDATION

It is recommended that for heavy duty application for tubes with bigger wall thickness than given in the catalog to pre-roll and flare the tube with KS or FTKS type tube expander

1/2" (12,7 mm)
TUBE PROJECTION

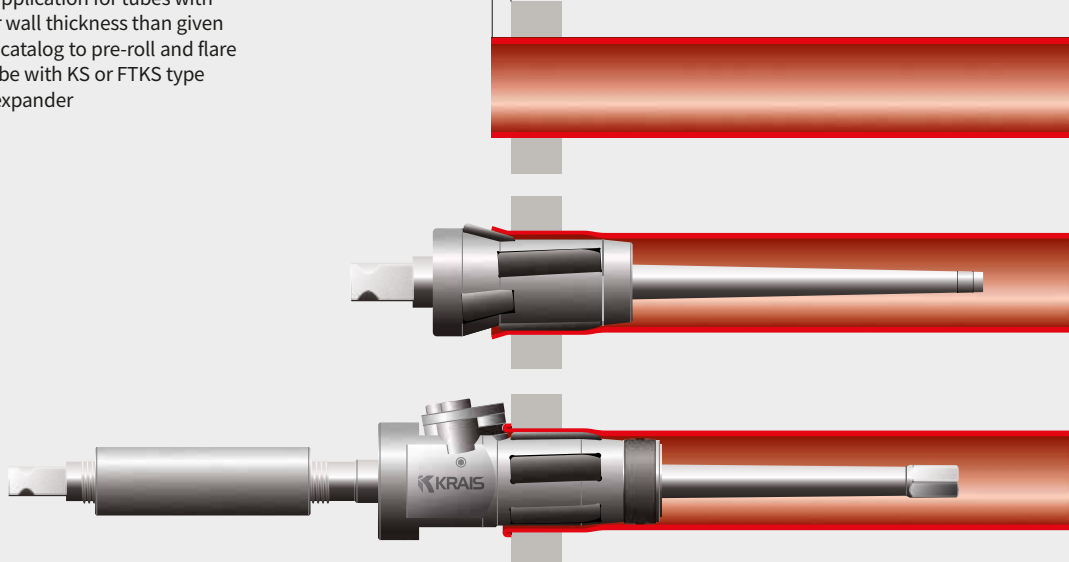

Colins Expander

The CBTE series offers non-parallel, self-feeding boiler tube expanders, suitable for tube sizes ranging from 1/2" to 4". These expanders are ideal for both new installations and repair work on thin tube sheets or leaky joints. They are recommended for tube sheets with a thickness between 1/8" and 5/8" (3 mm to 16 mm).



TUBE OD		GAUGE [BWG]	TUBE ID				TOOL NO.	EXPANSION RANGE				ROLLS NO.	MANDREL NO.	MANDREL SQUARE	
[INCH]	[MM]		MIN	MAX	MIN	MAX		MIN	MAX	MIN	MAX			[INCH]	[MM]
1/2"	12,70	16-17	0,370	0,384	9,40	9,76	CBTE-10	0,352	0,435	8,94	11,05	RS-13	MS-22	3/8"	9,52
		18-19	0,402	0,416	10,22	10,56	CBTE-11	0,382	0,465	9,70	11,81	RS-13	MS-23	3/8"	9,52
5/8"	15,88	14	0,459	0,459	11,65	11,65	CBTE-13	0,438	0,521	11,12	13,23	RS-14	MS-24	3/8"	9,52
		15-17	0,481	0,509	12,21	12,93	CBTE-15	0,462	0,566	11,73	14,37	RS-15	MS-25	3/8"	9,52
		18-19	0,527	0,541	13,39	13,73	CBTE-17	0,490	0,620	12,44	15,74	RS-15	MS-26	3/8"	9,52
3/4"	19,05	10	0,482	0,482	12,25	12,25	CBTE-15	0,462	0,566	11,73	14,37	RS-15	MS-25	3/8"	9,52
		11-12	0,510	0,532	12,95	13,51	CBTE-17	0,490	0,620	12,44	15,74	RS-15	MS-26	3/8"	9,52
		13-15	0,560	0,606	14,23	15,39	CBTE-19	0,538	0,688	13,66	17,47	RS-16	MS-26	3/8"	9,52
		16-17	0,620	0,634	15,75	16,11	CBTE-21	0,596	0,752	15,13	19,10	RS-17	MS-27	3/8"	9,52
7/8"	22,22	18-19	0,652	0,916	16,57	23,26	CBTE-22	0,620	0,776	15,75	19,71	RS-18	MS-27	3/8"	9,52
		11	0,635	0,635	16,12	16,12	CBTE-21	0,596	0,752	15,13	19,10	RS-17	MS-27	3/8"	9,52
		12	0,657	0,657	16,68	16,68	CBTE-22	0,620	0,776	15,75	19,71	RS-18	MS-27	3/8"	9,52
		13-14	0,685	0,709	17,40	18,00	CBTE-23	0,650	0,806	16,51	20,47	RS-19	MS-27	3/8"	9,52
1"	25,40	15-17	0,731	0,759	18,56	19,28	CBTE-24	0,710	0,866	18,03	21,99	RS-19	MS-28	1/2"	12,70
		9	0,704	0,704	17,88	17,88	CBTE-23	0,650	0,806	16,51	20,47	RS-19	MS-27	3/8"	9,52
		10-11	0,732	0,760	18,60	19,30	CBTE-24	0,710	0,866	18,03	21,99	RS-19	MS-28	1/2"	12,70
		12-13	0,782	0,810	19,86	20,58	CBTE-25	0,760	0,916	19,30	23,26	RS-20	MS-28	1/2"	12,70
1-1/8"	28,58	14-16	0,834	0,870	21,18	22,10	CBTE-26	0,812	0,968	20,62	24,58	RS-21	MS-28	1/2"	12,70
		17-18	0,884	0,902	22,46	22,92	CBTE-27	0,861	1,018	21,88	25,85	RS-22	MS-28	1/2"	12,70
		12	0,908	0,908	23,06	23,06	CBTE-27	0,862	1,018	21,89	25,85	RS-22	MS-28	1/2"	12,70
1-1/4"	31,75	13-17	0,937	1,008	23,80	25,60	CBTE-29	0,890	1,173	22,60	29,80	RS-24	MS-29	1/2"	12,70
		9-12	0,949	1,028	24,10	26,10	CBTE-29	0,890	1,173	22,60	29,80	RS-24	MS-29	1/2"	12,70
1-3/8"	34,93	13	1,185	1,185	30,10	30,10	CBTE-31	1,150	1,398	29,20	35,50	RS-26	MS-29	1/2"	12,70
1-1/2"	38,10	11-12	1,260	1,280	32,00	32,50	CBTE-31	1,150	1,398	29,20	35,50	RS-26	MS-29	1/2"	12,70
		13-16	1,310	1,370	33,28	34,80	CBTE-32	1,274	1,524	32,35	38,70	RS-26	MS-30	3/4"	19,05
1-5/8"	41,28	11-13	1,385	1,435	35,17	36,45	CBTE-33	1,336	1,586	33,93	40,28	RS-27	MS-30	3/4"	19,05
1-3/4"	44,45	11-13	1,510	1,560	38,35	39,63	CBTE-36	1,462	1,712	37,13	43,48	RS-28	MS-30	3/4"	19,05
1-7/8"	47,63	11-13	1,635	1,685	41,52	42,80	CBTE-40	1,600	1,850	40,64	46,99	RS-29	MS-31	3/4"	19,05
2"	50,80	11-13	1,760	1,810	44,70	45,98	CBTE-44	1,724	1,974	43,78	50,14	RS-30	MS-31	3/4"	19,05
2-1/8"	53,98	11-13	1,885	1,935	47,87	49,15	CBTE-52	1,850	2,100	46,99	53,34	RS-31	MS-31	3/4"	19,05
2-1/4"	57,15	11-13	2,008	2,058	51,00	52,28	CBTE-56	1,980	2,230	50,28	56,64	RS-31	MS-32	1"	25,40
2-1/2"	63,50	11-13	2,260	2,310	57,40	58,68	CBTE-65	2,230	2,480	56,64	63,00	RS-32	MS-32	1"	25,40
2-3/4"	69,85	11-13	2,510	2,560	63,75	65,03	CBTE-66	2,480	2,730	63,00	69,35	RS-33	MS-32	1"	25,40
3"	76,20	10-13	2,732	2,810	69,40	71,38	CBTE-68	2,690	3,023	68,33	76,78	RS-33	MS-33	1"	25,40
3-1/4"	82,55	10-13	2,984	3,062	75,80	77,78	CBTE-70	2,940	3,273	74,67	83,13	RS-34	MS-33	1"	25,40
3-1/2"	88,90	10-13	3,232	3,310	82,10	84,08	CBTE-80	3,190	3,523	81,02	89,48	RS-35	MS-33	1"	25,40
3-3/4"	95,25	9-13	3,454	3,560	87,73	90,43	CBTE-84	3,412	3,745	86,66	95,12	RS-34	MS-35	1"	25,40
4"	101,60	9-13	3,704	3,810	94,08	96,78	CBTE-90	3,661	3,995	93,00	101,47	RS-35	MS-35	1"	25,40
4-1/2"	114,30	9-13	4,204	4,310	106,78	109,48	CBTE-100	4,161	4,449	105,70	113,00	RS-36	MS-35	1"	25,40

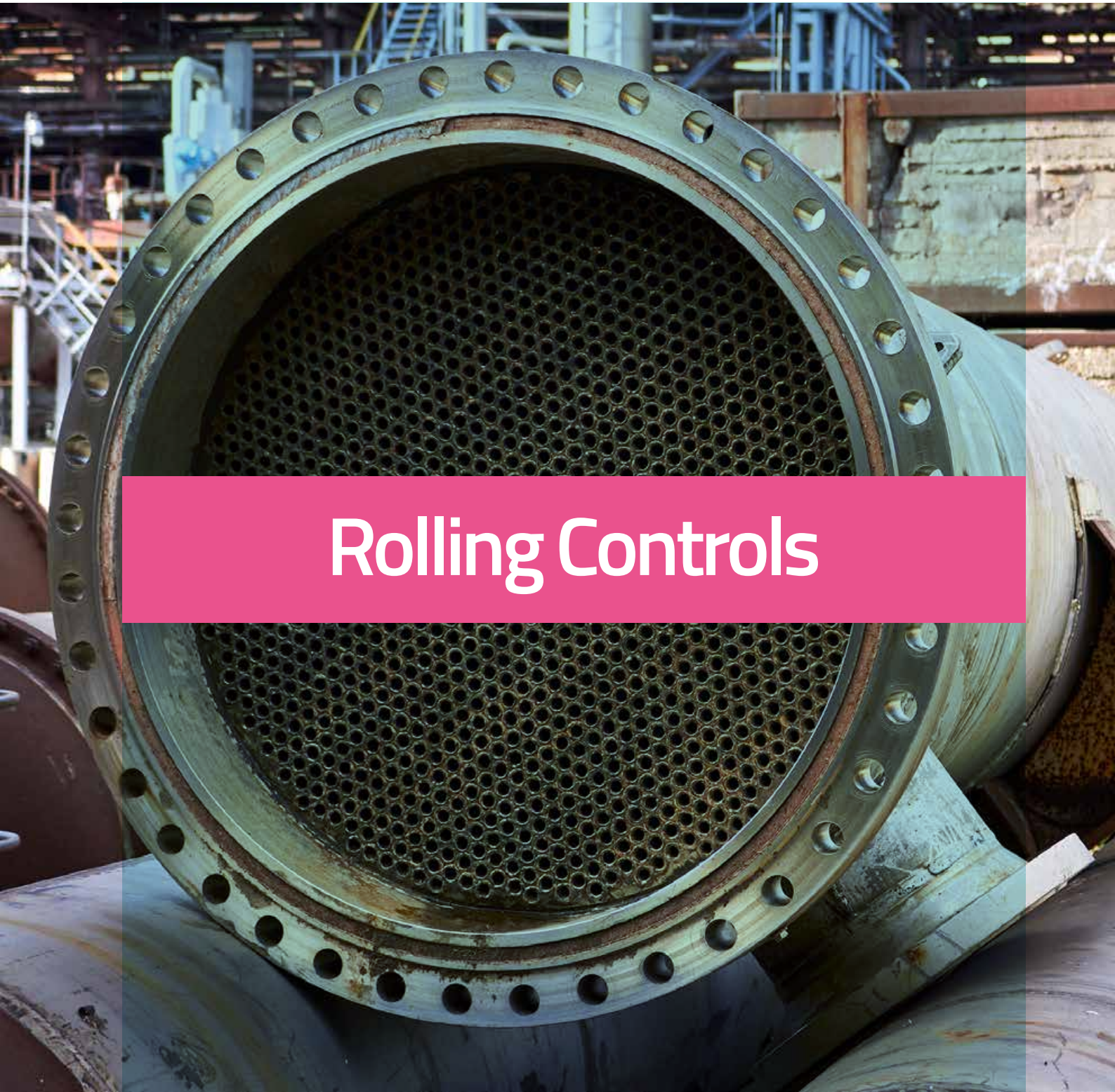

Rolling Controls

Rolling motors

K20 Series

K20 pneumatic rolling motor is designed for fast and accurate torque-controlled rolling of tubes from 1/4" – 1/2" OD (6.3 – 12.7 mm OD). This uniquely designed tool with automatic reverse expands tubes to a preset torque, at which point it automatically trips over to its reverse rotation, backing itself out of the tube ready for the next expansion. The process is fast and effortless, making it the ideal tool for production rolling applications. An in-line version is available on request. The 2026 version has a redesigned handle for a perfect fit for any hand size.



	TUBE OD		FREE SPEED	MIN TORQUE		MAX TORQUE		WEIGHT		LENGTH		AIR USE		SQUARE	CHUCKS	
	[INCH]	[MM]	[RPM]	[IN.LBS]	[NM]	[IN.LBS]	[NM]	[LBS]	[KG]	[INCH]	[MM]	[CFM]	[L/MIN]		INC.	OPT.
K20-550	1/2"	12,7	550	0,166	0,226	6,25	8,47	2,64	1,2	8,62	219	17	480	3/8"	1/4"	3/8"
K20-1800	3/8"	9,5	1800	0,166	0,226	2,25	3,05	2,42	1,1	8,07	205	17	480	3/8"	1/4"	3/8"
K20-2500	1/4"	6,3	2500	0,166	0,226	0,66	0,9	2,29	1,1	8,07	205	17	480	3/8"	1/4"	3/8"

Push&Pull K50 Series

K50 series pneumatic motors has been specifically engineered to ensure uniform tube to tube sheet expansions, thereby preventing the under and over rolling of tubes. This pneumatic tool features an aluminum body, weighing in at only 10.5 lbs (4.76 kg) with an ergonomically correct push/pull throttle. Automatically stops tube expansion at defined settings.



	TUBE OD		FREE SPEED	MIN TORQUE		MAX TORQUE		WEIGHT		LENGTH		AIR USE		SQUARE	CHUCKS	
	[INCH]	[MM]	[RPM]	[IN.LBS]	[NM]	[IN.LBS]	[NM]	[LBS]	[KG]	[INCH]	[MM]	[CFM]	[L/MIN]		STD.	OPT.
K50-1250	3/4"	19	1250	14,00	1,58	108	12,20	10,5	4,76	12 1/4"	311	60	1700	3/8"	3/8"	1/2"
K50-600	1"	25,4	485	22,00	2,49	193	21,81	10,5	4,76	12 1/4"	311	60	1700	3/8"	3/8"	1/2"
K50-400	1 1/4"	31,7	400	44,15	5,00	318	36,00	10,5	4,76	12 1/4"	311	60	1700	3/8"	3/8"	1/2"

AK50 Automatic Rolling Motor

AK50 tube rolling motor with automatic reverse. The machine automatically:

- ▶ start up when the expander is located in the tube;
- ▶ reverse the revolution to the left once determine the set up torque;
- ▶ stop when expander is withdrawn from the tube
- ▶ thanks to delay timer, machine automatically runs in forward direction after defined period from end of previous expansion ("NS" option)
- ▶ automatic tube expander lubrication ("L" option)

All the other features are the same as for standard K50 rolling motors.



	TUBE OD		FREE SPEED	MIN TORQUE		MAX TORQUE		WEIGHT		LENGTH		AIR USE		SQUARE	CHUCKS	
	[INCH]	[MM]	[RPM]	[IN.LBS]	[NM]	[IN.LBS]	[NM]	[LBS]	[KG]	[INCH]	[MM]	[CFM]	[L/MIN]		STD.	OPT.
AUTO K50-1250	3/4"	19	1250	14,00	1,58	108	12,20	10,5	4,76	12 1/4"	311	60	1700	3/8"	3/8"	1/2"
AUTO K50-600	1"	25,4	485	22,00	2,49	193	21,81	10,5	4,76	12 1/4"	311	60	1700	3/8"	3/8"	1/2"
AUTO K50-400	1 1/4"	31,7	400	44,15	5,00	318	36,00	10,5	4,76	12 1/4"	311	60	1700	3/8"	3/8"	1/2"

Rolling motors

K60 Series

K60 rolling motors control expansion by the accurate measurement of torque. They automatically stop expanding according to a predetermined setting. Torque control prevents over- and under-expansion of tubes, assures uniformly tightened tube joints, and provides maximum holding strength for individual tubes. All K60 motors include torque sensing cams designed and manufactured specifically for tube expanding applications.

- ▶ Strong, lightweight aluminum housings for easier handling and less operator fatigue
- ▶ Rugged drive combines precision control and measured torque output
- ▶ Simple dial-a-torque adjustment collar for easy set up
- ▶ Cushioned shut-off reduces torque reaction
- ▶ Quick change chucks to improve productivity



	TUBE OD		FREE SPEED	MIN TORQUE		MAX TORQUE		WEIGHT		LENGTH		AIR USE		SQUARE	CHUCKS	
	[INCH]	[MM]	[RPM]	[FT.LBS]	[NM]	[FT.LBS]	[NM]	[LBS]	[KG]	[INCH]	[MM]	[CFM]	[L/MIN]		STD.	OPT.
K60-900	1-1/2"	38,1	756	4,7	6,4	30,7	41,6	27	12,25	18	457	1980	70	1/2"	3/8, 1/2	3/4, 1
K60-400	2"	50,8	400	10,0	12,8	61,0	82,5	27	12,25	18	457	1980	70	3/4"	3/4, 1	3/8, 1/2
K60-250	2-1/2"	63,5	220	25,0	33,9	100,0	135,5	27	12,25	18	457	1980	70	3/4"	3/4, 1	3/8, 1/2

AK60NS Automatic Rolling Motor

AK60NS is a tube rolling motor with the fully automatic reverse system. The machine automatically:

- ▶ startup rotating in the forward direction;
- ▶ reverse the revolution to the left once determine the setup torque;
- ▶ thanks to adjustable delay timer, the machine automatically runs in forwarding direction after a defined period from the end of a previous expansion;
- ▶ automatic tube expander lubrication "L" is available optionally.

All the other features are the same as for standard K60 rolling motors.



	TUBE OD		FREE SPEED	MIN TORQUE		MAX TORQUE		WEIGHT		LENGTH		AIR USE		SQUARE	CHUCKS	
	[INCH]	[MM]	[RPM]	[FT.LBS]	[NM]	[FT.LBS]	[NM]	[LBS]	[KG]	[INCH]	[MM]	[CFM]	[L/MIN]		STD.	OPT.
AK60NS-1200	1"	25,4	1200	3,8	5,0	19,0	25,0	27	12,25	18	457	1980	70	1/2"	3/8, 1/2	3/4, 1
AK60NS-900	1-1/2"	38,1	756	4,7	6,4	30,7	41,6	27	12,25	18	457	1980	70	1/2"	3/8, 1/2	3/4, 1

AUTO K60 ON SITE



Auto K60 fastened on the Flexpander.

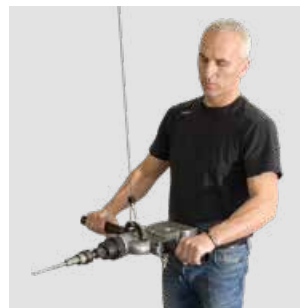

K60 fastened on the rope balancer.

Righ Angle rolling motors

K70 Right Angle Series

K70 Torque Controlled Rolling Motors have been designed for the Boiler Tube Industry. Tools have a unique head design which features a fully enclosed bearing design for long and trouble free life.

With industry input, our tools have been specifically engineered to precisely and consistently expand tubes in Steam / Mud Drums, Fire Tube and related Boilers and Equipment.

All models are equipped with a roll throttle as standard, a lever throttle is optional.



K70 OPTIONAL ACCESSORIES



Right angle gear drive



Parallel gear drive



Single universal joint

	TUBE OD		FREE SPEED	MIN TORQUE		MAX TORQUE		WEIGHT		LENGTH		HEIGHT WITHOUT SQUARE DRIVE		SIDE TO CENTER		SQUARE	CHUCK	
	[MM]	[INCH]	[RPM]	[NM]	[FT.LBS]	[NM]	[FT.LBS]	[KG]	[LBS]	[MM]	[INCH]	[MM]	[INCH]	[MM]	[INCH]		INC.	OPT.
K72-RT-90	101,6	4"	90	200	150	410	305	6,7	14,75	550	21,7	70	2,75	37	1,5	3/4"	1", 3/4"	-
K72-LT-90	101,6	4"	90	200	150	410	305	6,7	14,75	550	21,7	70	2,75	37	1,5	3/4"	1", 3/4"	-
K73-RT-190	63,5	2,5"	190	95	70	200	140	5,8	13,00	530	20,1	65	2,60	28	1,1	3/4"	3/4"	1/2"
K73-LT-190	63,5	2,5"	190	95	70	200	140	5,8	13,00	530	20,1	65	2,60	28	1,1	3/4"	3/4"	1/2"
K73-RT-280	57,1	2,25"	280	60	44	140	104	5,8	13,00	530	20,1	65	2,60	28	1,1	3/4"	3/4"	1/2"
K73-LT-280	57,1	2,25"	280	60	44	140	104	5,8	13,00	530	20,1	65	2,60	28	1,1	3/4"	3/4"	1/2"
K73-RT-375	50,8	2"	375	40	30	110	82	5,8	13,00	530	20,1	65	2,60	28	1,1	3/4"	3/4"	1/2"
K73-LT-375	50,8	2"	375	40	30	110	82	5,8	13,00	530	20,1	65	2,60	28	1,1	3/4"	3/4"	1/2"
K75-RT-30	152,0	6"	30	120	90	1230	922	7,5	16,50	620	24,0	70	2,75	37	1,5	1"	1"	1-1/4"
K75-LT-30	152,0	6"	30	120	90	1230	922	7,5	16,50	620	24,0	70	2,75	37	1,5	1"	1"	1-1/4"
K75-RT-60	127,0	5"	60	60	45	640	480	6,5	14,3	620	24,0	70	2,75	37	1,5	1"	1"	1-1/4"
K75-LT-60	127,0	5"	60	60	45	640	480	6,5	14,3	620	24,0	70	2,75	37	1,5	1"	1"	1-1/4"

LT - lever throttle; RT - roll throttle

K77 Right Angle Series

Torque controlled pneumatic rolling motor suitable for expanding tube up to 8" and refinery fittings.

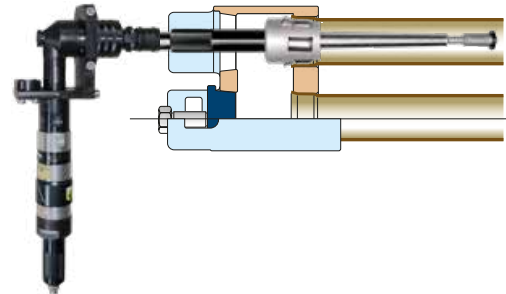

	TUBE OD		FREE SPEED	MIN TORQUE		MAX TORQUE		WEIGHT		LENGTH		HEIGHT WITHOUT SQUARE DRIVE		SIDE TO CENTER		SQUARE	CHUCK	
	[MM]	[INCH]	[RPM]	[NM]	[FT.LBS]	[NM]	[FT.LBS]	[KG]	[LBS]	[MM]	[INCH]	[MM]	[INCH]	[MM]	[INCH]		INC.	OPT.
K77-RT-25	203,2	8"	25	710	532	1455	1075	10	14,75	552	21,73	190	4,826	39	1,535	1"	1", 1-1/4"	1-1/2"
K77-LT-25	203,2	8"	25	710	532	1455	1075	10	14,75	552	21,73	190	4,826	39	1,535	1"	1", 1-1/4"	1-1/2"
K77-RT-8	203,2	8"	8	315	232	4300	3172	15	14,75	552	21,73	190	4,826	39	1,535	1"	1", 1-1/4"	1-1/2"
K77-LT-8	203,2	8"	8	315	232	4300	3172	15	14,75	552	21,73	190	4,826	39	1,535	1"	1", 1-1/4"	1-1/2"

LT - lever throttle; RT - roll throttle

FlexHolder System

The FlexHolder articulated arm supports the weight and absorbs the torque of the rolling motors and beveling machines using a pneumatic counterbalance, which allows the operator to effortlessly move the rolling motor into position.

- ▶ Positive tool holding system virtually eliminates the chance for operator error.
 - ▶ Increases expander life up to three times compared to conventional tube rolling.
 - ▶ Extends tool life by using the lubricated air from rolling motor's exhaust for cooling the rolls & mandrels, significantly reducing tooling cost.
- Standard model features 1,5 m vertical and 1,5 m horizontal reach (models with increased vertical and horizontal capacity are available upon request). Column can be easily removed from the base for the transportation purposes.

SPECIFICATION

Vertical movement	150 cm	59"
Horizontal movement	150 cm	59"
Minimum Lift Capacity	5 kg	10 Lbs
Lift Capacity	30 kg	37 Lbs
Allowable Torque	170 Nm	125 FtLbs



FLEXHolder can be supplied as a column, without trolley, which can be fixed to the floor, your own trolley or any other preferred way.



TES Mini 2

TES Mini 2 is a semi automatic torque controller for the precise expansion of ferrous, non-ferrous and alloy tubing. It is ideal for condenser/chillers, heat exchangers and boilers. It's one of most popular tools because of its accuracy, speed and ease of use.

The second generation TES Mini has been designed with direct input from our customers and utilizes the latest electronic components. As a direct result of these new technologies, gains in precision and energy efficiency have been realized from an already accurate system ($\pm 1\%$). The redesigned control panel is simpler to navigate and incorporates a built in card reader for detailed work reports.

MAIN TES MINI 2 FEATURES

- ▶ microprocessor controlled tube expansion;
- ▶ consistent torque control over 1 or 10,000 expansions;
- ▶ controls torque during long series of tube expanding;
- ▶ programmable torque shut-off value and high/low torque limits;
- ▶ reverse button for retracting expanders from the tubes;
- ▶ programmable timers for; cycle start, reverse pause, end of cycle, and a suppression timer for low torque value settings;
- ▶ CE Certified design.

Usage of our TES Mini 2 Controller, which is durable and easy to maintain, ensures that all tubes are expanded to the same torque. With the proper, easy to use set up, you can avoid over rolling which damages joint integrity and the distortion of tube sheet ligaments.

TES MINI 2 FUNCTIONS

- ▶ speed adjustment or limit (depends on motor type)
- ▶ torque adjustment
- ▶ suppression time adjustments
- ▶ pause time adjustments
- ▶ softstart delay
- ▶ report generation (up to 9999 cycles)
- ▶ works with 110 V and 230 V

DIMENSIONS



TES Mini 2

TES MINI 2 MOTORS

TES Mini in conjunction with one of our tube rolling motors will improve productivity and safety, while delivering unmatched performance and durability.

DRIVE	TUBE OD	TUBE OD		FREE SPEED	MAX RPM UNDER LOAD	MOTOR POWER	TORQUE				WEIGHT	
		MIN	MAX				[NM]		[FT-LBS]		[KG]	[LBS]
							MIN	MAX	MIN	MAX		
	HT-0	1/4	1/2	2300	1700	460 W	0,70	10,00	0,5	7,4	1,2	2,6
	MS-2	5/8	1 1/8	650 1200	430 760	1150 W	8,30 5,50	40,00 25,00	6,1 4,1	29,5 18,4	3,2	7,1
	DU-0	5/8	1	628 2100	450 1550	650 W	7,30 2,70	30,00 10,40	5,4 2,0	22,1 7,7	2,0	4,4
	DU-1	3/4	2	150 250 445 720	120 219 380 650	2000 W	12,00	250,00	8,9	184,4	8,6	19,0
	K90-E-90	2	5	90	81	1150 W	70,00	510,00	51,6	376,2	10,0	22,0
	K90-E-190	1 1/2	3	142	129	1150 W	50,00	260,00	36,9	191,8	10,0	22,0
	K90-E-280	1 1/4	2 1/2	274	250	1150 W	40,00	190,00	29,5	140,1	10,0	22,0

* Tube Capacity depends on material and technical condition of tube

TES-2000 Digital Tube Expanding System

Transform your tube expansion process with the TES 2000 Digital Tube Expanding System – a solution designed for precision, efficiency, and ease of use.

PRECISION AND CONTROL

The TES 2000 Controller is the heart of this system, offering durable performance and effortless maintenance. Its advanced digital capabilities ensure that every tube is expanded to the exact same torque, eliminating the risks of over-rolling and distortion of tube sheet ligaments. Experience unparalleled accuracy with variable speed and torque repeatability of +/- 1%.

HIGH-TECH INNOVATION

Equipped with a state-of-the-art servo drive, the TES 2000 guarantees high-quality, repeatable results. This purely digital and modular system adapts seamlessly to a wide range of tube diameters and materials, making it the ideal choice for demanding applications. Whether you're working with standard or exotic materials, the TES 2000 delivers consistent, reliable performance every time.

DESIGNED FOR EASE AND EFFICIENCY

Simplicity meets sophistication with the TES 2000. The system is designed for easy setup, allowing you to get started quickly and efficiently. Its user-friendly interface and programmable features, including adjustable speed and torque settings, programmable timers, and report generation, provide complete control over your expansion process.

TECHNICAL SPECIFICATIONS

- Tube compatibility: ½" – 1 1/4"
- Power supply: 230V, 50/60Hz
- Supported languages: english
- System is fully CE compliant and fully adheres to RoHS standards

CUTTING-EDGE FUNCTIONS

The TES 2000 is packed with features to enhance your workflow:

- ▶ Speed and torque adjustments for precise control.
- ▶ Programmable timers for cycle start, reverse pause, and end of cycle.
- ▶ Low torque suppression timer to prevent damage.
- ▶ Internal storage for log files, supporting up to 9999 cycles.



TES-2000 MOTOR

	RPM		TORQUE NM		TORQUE FT-LBS		WEIGHT	
	MIN	MAX	MIN	MAX	MIN	MAX	KG	LBS
GEAR 1:1	400	5000	1,25 Nm	8,4 Nm	0,92 Ft-Lbs	6,20 Ft-Lbs	5 kg	11,02 lbs
GEAR 1:6	70	800	8,00 Nm	46 Nm	5,90 Ft-Lbs	33,93 Ft-Lbs		



USER-FRIENDLY INTERFACE

The Text Panel (TP) series HMI provides a straightforward, monochrome text and graphical interface with physical membrane buttons. While simple in appearance, this interface offers robust control functions and easy operation, making it accessible to users of all skill levels.

TES-2000 Digital Tube Expanding System

EFFICIENCY AT ITS BEST

Designed for professionals who demand the best, the TES 2000 delivers uniform tube expansion with greater efficiency and accuracy. Its high-tech servo drive ensures that every expansion is performed to perfection, saving you time and effort.



TES units are equipped with top quality connectors.

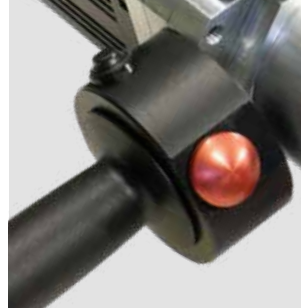

Easy-to-access button allows for convenient work control.



TELESCOPIC SHAFT



As an option, KRAIS offer an articulated telescopic shaft - convenient way to improve efficiency and option to machine most inaccessible tubes. The telescopic shaft is useful especially to roll tubes close and deep to the shell. The shaft is easy to handle, accurate and stable at all speeds.

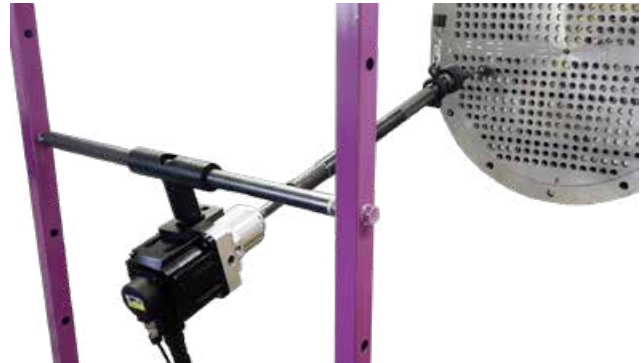

Built to work with the regular TES2000 motor and TES3000, G-1000, G-400, and G-1450 motors.

BASIC FEATURES

- Overall telescopic range:..... 940 - 1480 mm (37,0" - 58,3")
- Extensibility:..... 520 mm (20,5")
- Handle part length:..... 225 mm (8,9")
- Weight:..... 8 kg (17,6 Lbs)
- Max. torque: 120 Nm (88,5 FtLbs)

SERVO DRIVE WORKING SCHEME

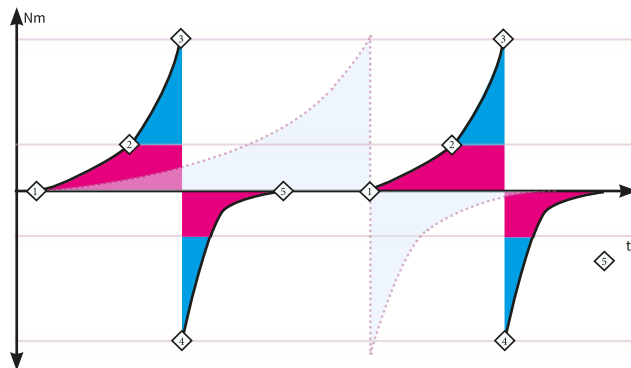

■ High speed; ■ Variable speed; ■ Constant speed
 — Servo drive rolling; Traditional rolling

FLEXHOLDER

To work with TES3000 controllers we recommend arm FlexHolder. This connection allows you to create a mobile workstation with an above average performance!



TES-3000

This Digital Tube Expanding System features a range of powerful and efficient servo motors. Variable Speed and Torque repeatability +/- 1% are a few of the advantages of this system. Created for the demanding customer, this system ensures uniform tube expansion over a wide range of tube diameters and materials, greater efficiency and accuracy combined with ease of use make this system, simple, affordable and extremely fast.

BASIC PARAMETERS

- ▶ Power supply:
- ▶ TES 3000: 400V 50/60Hz
- ▶ For tubes: ½" – 1 ½"
- ▶ Control unit weight: 14 kg
- ▶ Footswitch weight: 5 kg
- ▶ Dimensions: 800 x 200 x 900 mm

MAIN TES FEATURES

- ▶ Purely digital and modular system.
- ▶ High tech servo drive and motor assure accuracy, high quality and repeatability of the results and efficient work.
- ▶ Extremely easy and user friendly interface on 7" touch screen.
- ▶ Supported languages: English, Korean, German, Spanish, Portuguese, Chinese, Polish.
- ▶ USB Flash Drive available to dump expanding log files (48 MB of internal storage space for the log files)
- ▶ Easy software upgrade with USB flash memory
- ▶ CE compliant. In full accordance with RoHS compliance.
- ▶ Motor equipped with EnDat encoder.

APLS (OPTIONAL)

The automatic, pneumatic lubrication system is controlled by TES-3000 control box. It automatically shoots a drop of oil on the rolls before the expander is inserted into the expanded tube.



Special designed body shape for convenient of operator



USB host for easy software upgrade to latest version.



TES units are equipped with top quality connectors.

TES-3000 SPECIFICATION

Colors	65536
Resolution (W x H)	800 x 480
Back Light	LED
Processor	Cortex A8 600MHZ
Touch Panel Type	4 wires resistive type
Storage	128 MB Flash
RAM	128 MB
USB Host	USB 2.0 – software updates, dump the log files
CE	Complies with EN 55022:2006, Class A, EN 61000-3-2:2006, EN 61000-3-3:1995 + A1:2001 + A2:2005 standards
UL	E248297
Protection Structure	IP65 front panel
Storage Temperature	-20°-60°C (-4°-140°F)
Operating Temperature	0°-50°C (32°-122°F)
Operation Humidity	10-90% RH (non-condense)

SERVO DRIVE WORKING SCHEME

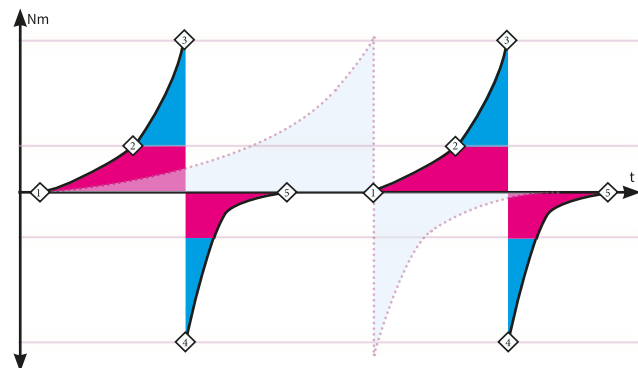

■ High speed; ■ Variable speed; ■ Constant speed
— Servo drive rolling; Traditional rolling

TES-3000

MOTORS FOR TES-3000

We offer a full range of motors, you can choose a proper one that fits your needs. Each motor is equipped with one of 5 of the gear boxes. Each with protection level IP56.

DRIVE		PHASE VOLTAGE	WEIGHT	MAX RPM	TORQUE (WITH TES-3000)			
					NM		FT.LB	
					MIN	MAX	MIN	MAX
	S3000	3/400V	5,0 kg	3000	0,2	2,5	0,10	1,80
	S6000	3/400V	5,0 kg	6000	0,2	2,5	0,10	1,80
	S5	3/400V	5,0 kg	1662	2,3	8,6	1,60	6,30
	S4	3/400V	5,0 kg	1500	2,7	9,5	1,90	7,00
	S3	3/400V	5,0 kg	1091	3,0	13,0	2,20	9,50
	S2	3/400V	5,0 kg	800	2,8	18,0	2,00	13,20
	S1	3/400V	5,0 kg	600	3,0	24,0	2,20	17,70
	S1-RA	3/400V	6,5 kg	320	2,2	45,0	1,62	33,0
	S2-RA	3/400V	6,5 kg	425	1,7	33,0	1,25	24,0
	S3-RA	3/400V	6,5 kg	580	1,1	24,0	0,81	17,0
	S4-RA	3/400V	6,2 kg	797	0,9	17,0	0,66	12,0
	S5-RA	3/400V	6,2 kg	884	0,7	16,0	0,51	11,0
	G3000	3/400V	9,5 kg	3000	0,5	18	3,68	13,27
	G2000	3/400V	9,5 kg	2000	0,8	23	5,9	16,96
	G1455	3/400V	9,0 kg	1453	2,3	70	1,6	51,6
	G1000	3/400V	9,0 kg	1000	3,4	102	2,5	75,2
	G400	3/400V	9,5 kg	400	7,5	240	5,5	177

MOTOR WHICH "FITS EVERYWHERE"

KRAIS Sx-RA is the series of compact, high customizable servo-controlled tube rolling motors.

The compact body, with a pistol grip, right-angle rolling motors are excellent for use in tight and hard to reach places with standard rolling motors. An especially places like tube sheet placed deep in the shell/partition or a condenser in desalination plant with tube sheet opposite to the wall.

Like all KRAIS servo motors – this unit assures differences less than 1% in repeatability of torque control. The convenient pistol grip can be position in 3 ways to suit the application and operator preferences. The pistol grip – for a better control – works as the hand switch with two triggers: for manual operation and emergency button. The machine is equipped with suspension for balancer.



MANY CUSTOM CONFIGURATIONS

Pistol grip at left side



Pistol grip at back



Pistol grip at right side



Pistol grip at left side with handle on bottom



Pistol grip at back with handle on bottom



Pistol grip at back side with handle on left



... plus many more, which can fit in all tough locations!

TES-3000

TELESCOPIC SHAFT



As an option, KRAIS offer an articulated telescopic shaft - convenient way to improve efficiency and option to machine most inaccessible tubes. The telescopic shaft is useful especially to roll tubes close and deep to the shell. The shaft is easy to handle, accurate and stable at all speeds.



Built to work within digital rolling system TES3000 with G-1000, G-400 and G-1450 motors.

If you need to work in the explosive environment, the telescopic shaft module is ready to work with pneumatic rolling motor AK60-900-NS.

BASIC FEATURES

Overall telescopic range:..... 940 - 1480 mm (37,0" - 58,3")
 Extensibility:..... 520 mm (20,5")
 Handle part length:..... 225 mm (8,9")
 Weight:..... 8 kg (17,6 Lbs)
 Max. torque: 120 Nm (88,5 FtLbs)

FLEXHOLDER

To work with TES3000 controllers we recommend arm FlexHolder. This connection allows you to create a mobile workstation with an above average performance!



KRAIS > Leading manufacturer of tools and machines for the tube & pipe industry

TES-3000 SOFTWARE



- ▶ Friendly interface and large touch screen allows to configure different motor types with their predefined min/max values and to set up required expanding parameters.
- ▶ Torque Wizard helps to calculate torque settings based on: %wl reduct, Feed Angle, Mandrel taper, Tube Diameter, Tube Yield (Ultimate tensile strength), Wall Thickness (Gauge, Expansion Length)
- ▶ 3 operating modes available: MANUAL: Single expansion, SEMIAUTO: Single expansion with autorevers, AUTO: Expansion with autorevers in endless loop until operator stops
- ▶ Configurable expanding timers: reverse rolling time, time between expanding cycles (to move expander from one to another tube), time to expand with maximum rpm in the initial expanding phase
- ▶ Other features: Expanding counter, Color status lamps, Metric and imperial units available, Translated to many languages.

G1000-COOLING

Additional cooling module 24Volt can be purchased to all motor without back D-handle



TES3000-APLS

Automatic Pneumatic Lubricating System. The system, dedicated and integrated for the 2022 version of TES-3000, dispenses oil drops precisely into the rolls and mandrel. It eliminates the problem of the correct amount of lubrication and reduces tool wear.



SwiftRoll Series

The Swiftroll robot is a cutting-edge solution designed for simultaneous tube expanding and facing. With three sizes available - XS, XM, and XL - Swiftroll offers versatile capabilities, while the Xm variant focuses specifically on tube expansion.

Based on 6 axis FANUC robot, a special version of TES3000 for CNC – digital controller for speed and expansion managing and KRAIS dual function, dual-g geared, 3 KW servo drive. All works under Fanuc R30iB system. SwiftRoll has an overload system in the event of a collision to prevent damages. SwiftRoll is delivered with built-in HMI software and PC laptop with custom CAM software for easy tube sheet programming. SwiftRoll is installed on the convenient steel platform.

As optional we can furnish the robot with: automatic referencing function, vision system and force sensors allow robots to detect force and torque. SwiftRoll can be built with a bigger robot that provides double capacity: bigger reach radius and lifting.



WORKING RANGE			STANDARD MOTOR PARAMETERS			
AXIS NUMBER	REACH RADIUS	LIFTING	ROLLING SPEED	ROLLING TORQUE	FACING SPEED	POWER
6	1200 mm	20 Kg	Up to 1000 Rpm	102 Nm	Up to 1000 Rpm	3 KW
	47,00"	44 Lbs		75 Ft.Lbs		

TES3000 - SEPARATE UNIT



The TES3000 for CNC can also be used as the independent rolling system. Can be used with FlexHolder, telescopic shaft or handheld. And, thanks to the wide range of motor drives, TES3000 for CNC can be used to process expansion of tubes in varies sizes and materials.

R3000 - NEW DRIVE



Newest range of motors for tube rolling and facing in one. Torque range from 0,5 Nm to 50 Nm and speed from 200 to 3000 Rpm (depends on application).

SWIFTROLL XS



SwiftRoll XS the smallest version of the SwiftRoll. Designed for small cooler manufacturers. With this version, the tube facing is not available. Available motors up to 6000 rpm.

SwiftRoll X1

CUSTOM HMI SOFTWARE



The robot is delivered with the pre-installed KRAIS HMI system dedicated exclusively to support of referencing, tube expanding, tube facing and welding tubes to tube sheet.

The system has been written to facilitate the operation of the robot and to hide functions that may be unnecessary in the working process or are too advanced at the very beginning of learning.

INCLUDED CAM SOFTWARE

Unique feature delivered as standard is full featured, customized CAM software. In a very short period of time allows creating programs for tube expanding, facing or welding to tube sheet.

Software functions allow measuring all tube sheet parameters based on sheet drawing. The precise definition of tube holes locations is determined in few clicks. Calibration, made by robot's header, joins information from drawing with the real sitting of the tube sheet. The whole process takes minutes.

One of the essential functions of software is a possibility to automatically programming the order of expanding tubes. It is very important to avoid tube sheet deformation while expanding from the top to the bottom or another way around.

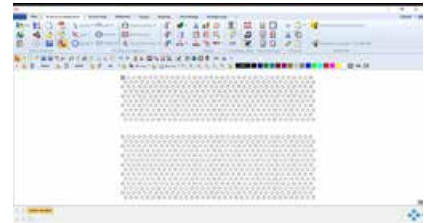

SWIFTROLL IN ACTION



Simultaneous machining of two (!) tube sheets. Both of them were prepared earlier and now they need tube facing and expanding. After an hour setup, all work is done totally automatically.



Installation Tools

Tube Hole Gauge

Tube Hole Gauges utilize a precision three-point contact, self-centring system, for measuring both Tube and Tube sheet ID. Our Reversible Dial Plate, allows the user to measure in both inch/decimal and metric units. Our standard adjustable depth is 4" or 8" (101 or 203 mm) dependent on model. We offer additional 8" (203 mm) reach extensions to increase the capacity of these tools for Fin Fan and similar units. All gages are furnished with both setting ring and carrying case.



SIZE*		ID RANGE				TOOL NUMBER		REACH		SETTING RING	MANDREL EXTENSION	BODY EXTENSION
		MIN		MAX								
[INCH]	[MM]	[INCH]	[MM]	[INCH]	[MM]	IMPERIAL	METRIC	[INCH]	[MM]			
3/8	9,53	0,290	0,350	7,37	8,89	K200-375	K200-95	4	101,6	SR-3/8	K200-95-ME	K200-95-BE
1/2	12,70	0,350	0,450	8,89	11,43	K200-500	K200-127	4	101,6	SR-1/2	K200-127-ME	K200-127-BE
5/8	15,88	0,440	0,560	11,18	14,22	K200-625	K200-158	4	101,6	SR-5/8	K200-158-ME	K200-158-BE
3/4	19,05	0,550	0,715	13,97	18,16	K200-750	K200-190	8	203,2	SR-3/4	K200-190-ME	K200-190-BE
7/8	22,23	0,675	0,840	17,15	21,34	K200-875	K200-222	8	203,2	SR-7/8	K2000-222-ME	K200-222-BE
1	25,40	0,800	0,965	20,32	24,51	K200-1000	K200-254	8	203,2	SR-1	K200-254-ME	K200-254-BE
1 1/4	31,75	0,950	1,170	24,13	29,72	K200-1250	K200-317	8	203,2	SR-1-1/4	K200-317-ME	K200-317-BE
1 3/8	34,93	1,085	1,295	27,56	32,89	K200-1375	K200-350	8	203,2	SR-1-3/8	K200-350-ME	K200-350-BE
1 1/2	38,10	1,240	1,450	31,50	36,83	K200-1500	K200-381	8	203,2	SR-1-1/2	K200-381-ME	K200-381-BE
1 3/4	44,45	1,476	1,685	37,49	42,80	K200-1750	K200-444	8	203,2	SR-1-3/4	K200-444-ME	K200-444-BE
2	50,80	1,700	1,910	43,18	48,51	K200-2000	K200-508	8	203,2	SR-2	K200-508-ME	K200-508-BE
2 1/4	57,15	1,948	2,16	49,479	54,86	K200-2250	K200-571	8	203,2	SR-1-1/4	K200-571-ME	K200-571-BE
2 1/2	63,50	2,200	2,41	55,880	61,21	K200-2500	K200-635	8	203,2	SR-2-1/2	K200-635-ME	K200-635-BE
3	76,20	2,660	2,87	67,564	72,90	K200-3000	K200-762	8	203,2	SR-3	K200-762-ME	K200-762-BE

* other sizes on request

FREE GAUGE ADJUSTMENT

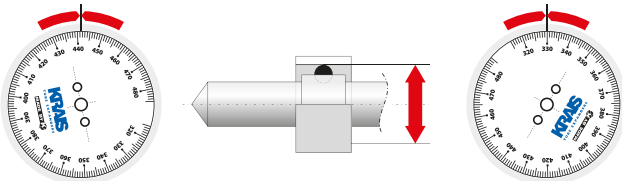

LONG VERSION (UP TO 3M)

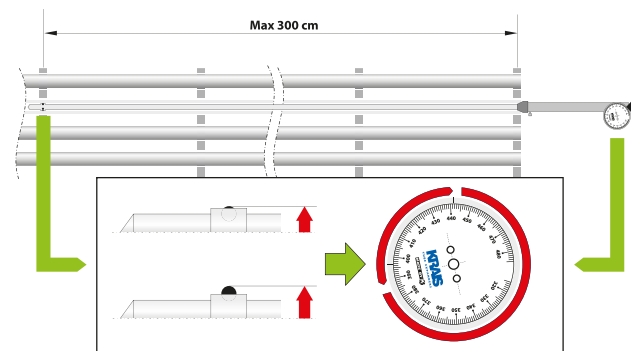

Vacuum Leak Tester KVLD-3000

The vacuum leak tester KVLD-3000 is a simple, precise method of testing tubes in boilers, condensers, and heat exchangers. It is the fastest, most accurate means of locating leaky tubes for plugging or replacement.

- ▶ Only one tool necessary for testing multiple tube sizes.
- ▶ Built-in easy to read vacuum gauge.
- ▶ Muffled exhaust for quiet operation.
- ▶ Lightweight, easy to use.

SPECIFICATIONS

- ▶ Cover wide range of tubes with one unit (tube sizes: 1/4" (6,3) to 3" (76,2 mm)).
- ▶ Requires 90 PSI (6,2 bar) compressed air.
- ▶ Air consumption: 26 C.F.M. (720 l/min).
- ▶ Carrying case measures: 16" x 12" x 4" (410 x 300 x 85 mm).
- ▶ Tool weight: 4,4 lbs (1,2 kg).
- ▶ Approximate shipping weight: 6,6 lbs (3,0 kg).

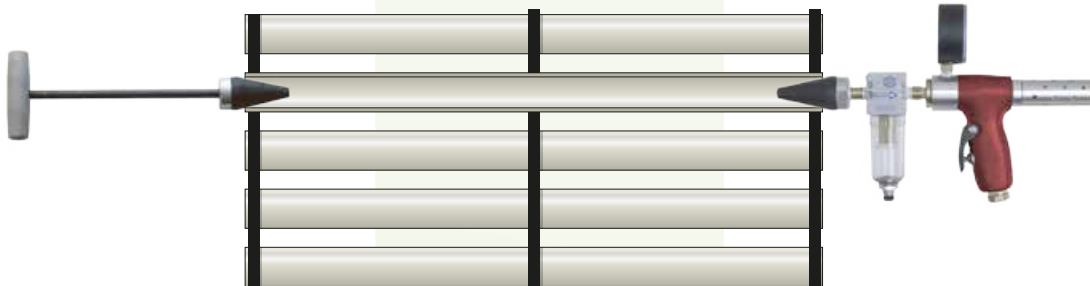

NOZZLES AVAILABLE

PART NUMBER	TUBE OD
K-1002	1/4" (6,3 mm) - 3/4" (19 mm)
K-1003	5/8" (15,9 mm) - 1 1/4" (31,7 mm)
K-1004	1 1/8" (28,6 mm) - 2" (50,8 mm)
K-1005	1 7/8" (47,6 mm) - 3" (76,2 mm)

OPERATING INSTRUCTIONS

1. Seal far end of tube to be tested with "t" handle type tube plug or optional snap type tube plug.
2. Place nozzle of tester into near end of tube.
3. Squeeze trigger of test unit until gauge reaches desired reading.
4. Release trigger and observe gauge.
5. A steady reading on gauge indicates no leaks.
6. Move to next tube and repeat.

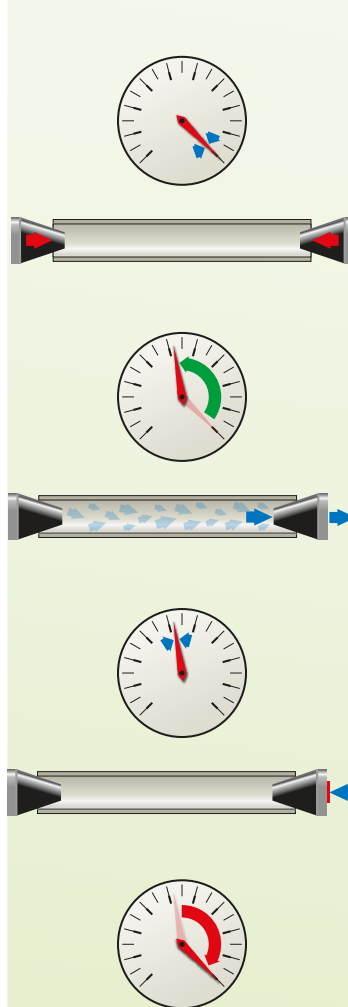

Basic installation tools

TEF – Tube End Facer



Typical application for TEF is the tube trimming of heat exchanger, condenser and chiller tubes to a uniform 1/8" (3 mm) tube projection after tube rolling. This will fit into all electric and pneumatic power tools equipped with a 1/2" Jacobs chuck. The tool is fitted with a three slot collar for precision adjustment and features a very simple mechanism for tool bit replacement. TEF is equipped with a hex shank as standard.

Work best with KDM - Krais Drilling Machine.



Tool for Serrating Tube Sheet



Portable, self-centering tool for grooving tube sheet. Unique single-piece mandrel with built-in rollers in the part that operates directly in the hole allows obtaining a perfect surface, free from burrs and flashes.

The latter was formed with the previous designs during the friction of the mandrel against the walls of the hole - now, it is eliminated through the use of rollers - the mandrel rolls over the walls of the hole. Owing to the lack of friction the life of the tool has grown very significantly. As an option, the tool can be delivered with a special channel conducted inside the mandrel. Channel serving the purpose of feeding the cooling medium directly through the tool cutter, this having an enormous impact on the life of the cutter and helping in rinsing out chips during the work.

Grooving tools can be used both on portable and stationary multiradial drills. They also find their application on CNC machine tools.

JGS grooving tools are manufactured within a broad range of sizing: from 3/8" (9.52 mm) up to 4" (101.6 mm), in both imperial and metric versions. As a standard, the tools have an adjustment system for channel cutting reach, 22.2 mm to 54.0 mm (as counted from the bottom face to the internal edge of the channel being cut).

Work best with KDM - Krais Drilling Machine.



CUTTER BITS



Example of cutter bits, available as optional.

NOTE!

For tube sheet holes bigger up to 0,25 mm than tube OD the tailor-made mandrel should be considered. Hole bigger more than 0,25 mm may create a damage of the tool mandrel or drilling machine!

TUBE OD		TOOL NO.	PILOT RANGE	SPARE BITS	
[INCH]	[MM]			NON FERROUS OR CARBON STEEL	STAINLESS
3/8"	9,50	TEF-375	16 – 20	TEF-376	TEF-376-SS
1/2"	12,7	TEF-500	16 – 20	TEF-506	TEF-506-SS
5/8"	15,8	TEF-625	14 – 20	TEF-626	TEF-626-SS
3/4"	19,0	TEF-750	12 – 20	TEF-756	TEF-756-SS
7/8"	22,2	TEF-875	14 – 18	TEF-876	TEF-876-SS
1"	25,4	TEF-1000	10 – 18	TEF-1006	TEF-1006-SS
1-1/4"	31,7	TEF-1250	10 – 18	TEF-1256	TEF-1256-SS
1-1/2"	38,1	TEF-1500	10 – 18	TEF-1506	TEF-1506-SS
2"	50,8	TEF-2000	10 – 18	TEF-2006	TEF-2006-SS
2-1/2"	63,5	TEF-2500	10 – 18	TEF-2506	TEF-2506-SS

IMPERIAL VERSION TOOLS

Tool No.	Tube OD	Tool Bits (spacing)		
	[inch]	1/8 x 1/4 x 1/8"	1/8 x 3/8 x 1/8"	1/8 x 1/8 x 1/8"
JGS-375	3/8"	ST-3703-S	ST-3703	ST-3703-SPEC
JGS-500	1/2"	ST-5003-S	ST-5003	ST-5003-SPEC
JGS-625	5/8"	ST-6203-S	ST-6203	ST-6203-SPEC
JGS-750	3/4"	ST-7503-S	ST-7503	ST-7503-SPEC
JGS-875	7/8"	ST-7503-S	ST-7503	ST-7503-SPEC
JGS-1000	1"	ST-7503-S	ST-7503	ST-7503-SPEC
JGS-1250	1-1/4"	ST-7503-S	ST-7503	ST-7503-SPEC
JGS-1500	1-1/2"	ST-7503-S	ST-7503	ST-7503-SPEC
JGS-2000	2"	ST-7503-S	ST-7503	ST-7503-SPEC
JGS-2500	2-1/2"	ST-7503-S	ST-7503	ST-7503-SPEC

METRIC VERSION TOOLS

Tool No.	Tube OD	Tool Bits (spacing)		
	[mm]	3 x 6 x 3 mm	3 x 9 x 2 mm	3 x 3 x 3 mm
JGS-375-10	10,00	GS-106	GS-109	GS-103
JGS-500-12	12,00	GS-206	GS-209	GS-203
JGS-625-16	16,00	GS-306	GS-309	GS-303
JGS-750-20	20,00	GS-406	GS-409	GS-403
JGS-875-22	22,00	GS-406	GS-409	GS-403
JGS-1000-25	25,00	GS-406	GS-409	GS-403
JGS-1250-32	32,00	GS-406	GS-409	GS-403
JGS-1500-38	38,00	GS-406	GS-409	GS-403
JGS-2000-51	51,00	GS-406	GS-409	GS-403

Other sizes and bits on request.

TOOL BIT SPACING



MWR-JGS Mini Grooving Tool

First in the world, quick, powerful, yet handheld machine for serrating tube sheet in heat exchangers, boiler drums, FinFan coolers and other tubular vessels that need grooves in the tube sheet. Tool uses one cutting bit for cut any material tubes.

This unique system safely and quickly produces grooves in under 20 second for 1" tube.

Can be used as a tool for maintenance companies as well as the production tool with our dual pneumatic locking system and pneumatic cooling and lubricating module.



CUTTING RANGE		FREE SPEED		POWER		TORQUE	
Up to 101,6 mm		100 Rpm		1,3 Hp		140 Nm	
Up to 4"						105 Ft.Lbs	
AIR USE		BODY WIDTH		BODY HEIGHT		BODY WEIGHT	
55 cfm	1,3 m3/min	2,32"	59 mm	13,1"	335 mm	17,5 Lbs	8 kg

MWR-JGS ON REGULAR TUBE SHEET



On standard heat exchangers machine locks onto two shafts on the adjacent holes. The locking plate is manufactured according to the tube hole pitch to ensure precise tool alignment.

MWR-JGS REACTION PLATES



Standard locking plate has 2 reaction shafts, located from each site of the spindle. We can also supply locking plate that has locking shaft located on one side of the spindle and can be rotated through 180 degrees to accommodate partition plates, channel heads etc.

MWR-JGS E

MWR-JGS E is the electric version of the Mini Grooving Tool. The standard machine covers the same tube sizes. The electric motor, made by Makita, has a 3 stage planetary gear box manufactured by KRAIS. It has variable speed control and produces enormous torque. It is interchangeable with our pneumatic drive and can be purchased at any time.

Free Speed 115 RPM
 Power 750 W
 Torque 368 Nm (280 Ft.Lbs)
 Feed Stroke 25 mm (1")



Full range of the grooving tools from 1/2" to 4"



The rollers over the circumference of the mandrel allow to achieve a perfect surface of the hole.

Grooving tools for MWR-JGS



TUBE SIZE	TOOL NUMBER	TOOL BIT 1/8X1/4X1/8"	TOOL BIT 3X6X3 MM	TOOL BIT SPRING	MANDREL	TURNING ROLS
1/2"	JGS-MWR-127	ST-5003-S	GS-206	ST-5011	GS-MWR-127	-
5/8"	JGS-MWR-158	ST-6203-S	GS-306	ST-6211	GS-MWR-158	-
16 mm	JGS-MWR-160	ST-6203-S	GS-306	ST-6211	GS-MWR-160	-
3/4"	JGS-MWR-190-R	ST-7503-S	GS-406	ST-7511	GS-MWR-190-R	STR-3-55
20 mm	JGS-MWR-200-R	ST-7503-S	GS-406	ST-7511	GS-MWR-200-R	STR-4-55
22 mm	JGS-MWR-220-R	ST-7503-S	GS-406	ST-7511	GS-MWR-220-R	STR-4-55
7/8"	JGS-MWR-222-R	ST-7503-S	GS-406	ST-7511	GS-MWR-222-R	STR-5-55
25 mm	JGS-MWR-250-R	ST-7503-S	GS-406	ST-7511	GS-MWR-250-R	STR-5-55
1"	JGS-MWR-254-R	ST-7503-S	GS-406	ST-7511	GS-MWR-254-R	STR-5-55
1-1/8"	JGS-MWR-285-R	ST-7503-S	GS-406	ST-7511	GS-MWR-285-R	STR-5-55
1-1/4"	JGS-MWR-317-R	ST-7503-S	GS-406	ST-7511	GS-MWR-317-R	STR-5-55
1-1/2"	JGS-MWR-381-R	ST-7503-S	GS-406	ST-7511	GS-MWR-381-R	STR-5-55
1-3/4"	JGS-MWR-444-R	ST-7503-S	GS-406	ST-7511	GS-MWR-444-R	STR-5-55
2"	JGS-MWR-508-R	ST-7503-S	GS-406	ST-7511	GS-MWR-508-R	STR-5-55
51"	JGS-MWR-510-R	ST-7503-S	GS-406	ST-7511	GS-MWR-510-R	STR-5-55
2-1/4"	JGS-MWR-751-R	ST-7503-S	GS-406	ST-7511	GS-MWR-751-R	STR-5-55
2-1/2"	JGS-MWR-635-R	ST-7503-S	GS-406	ST-7511	GS-MWR-635-R	STR-5-55
2-3/4" *	JGS-MWR-698-R	ST-7503-S	GS-406	ST-7511	GS-MWR-698-R	STR-5-55
3" *	JGS-MWR-762-R	ST-7503-S	GS-406	ST-7511	GS-MWR-762-R	STR-5-55
4" *	JGS-MWR-1002-R	ST-7503-S	GS-406	ST-7511	GS-MWR-1002-R	STR-5-55

* tool needs speed reducer

MiniDrill

MiniDrill is a unique machining platform designed to safely perform multiple machining operations on heat exchangers, boilers and similar thermal exchange equipment. Designed with operator safety in mind, this system can drill, ream, bore and even re-machine serrations in steam drums quickly and safely. With a 80 mm (3.150") travel, this tool is ideally suited for the majority of plant equipment. The system is fully torque reacted with 2 clamping arms that are independent of one another and can accommodate most pitch configurations. Once locked into the tubes, the MiniDrill is extremely stable.



AVAILABLE TOOLS WORKING WITH MINIDRILL



WALL REDUCING
Tube wall reducing head with carbide inserts.



DRILLING
Drill for machining holes in tube plugs before removing them with our special plug removal tool.



REAMMING
Safely ream tube sheets.



BORING HEAD
Boring head to machine heavy wall boiler tubes, safely and efficiently prior to collapsing through the drum.



OTHER AVAILABLE ACCESSORIES

MINIDRILL WITH FAST CLAMPING
MiniDrill with the fast pneumatic clamping system is ideal for manufacturing plants that make large amounts of work on tubes and pipes. It offers rapid tube to tube cycle time, increased productivity with little operator fatigue.



EXAMPLE TOOL APPLICATION



Reducing tube wall on a 6" thick tube sheet prior to punching.

MicroDrill

Specialized machine for precise plug removal

The MicroDrill is a compact tool for drilling, reaming, boring, and removing taper plugs—welded or non-welded—from heat exchangers. Its low-profile design allows mounting just 24 mm from the shell or partition plate, ensuring high accessibility in tight spaces. Built for operator safety and reliable performance.

KEY FEATURES

60 MM (2.4") TOOL TRAVEL

Covers most heat exchanger tube sheets; suitable for various equipment types.

STABLE AND ACCURATE

Firm clamping ensures precise, repeatable machining.

TORQUE-REACTIVE PLATFORM

Absorbs machining forces, improving safety and control.

INDEPENDENT CLAMPING SHAFTS

Two standard shafts (optional third) accommodate different tube pitch layouts.

OPERATOR SAFETY

Designed for quick, safe plug removal with minimal risk.



WORKING RANGE		LOCKING RANGE	POWER	TORQUE			
12,5– 38,0 mm	According to the drawing	0,98 Hp	18 Nm / 300 RPM (55 Nm / 100 RPM*)				
0,492 – 1,496"			13,28 Ft-lbs / 300 RPM (40,57 Ft-lbs / 100 RPM*)				
AIR USE		BODY WIDTH	BODY HEIGHT		BODY LENGTH		
17 cfm	0,48 m ³ /min	1,73"	44 mm	10,82"	275 mm	12,2"	310 mm

*with 3x Speed Reducer



RIGID LOCKING

On standard heat exchangers, MicroDrill machine secures itself in the tube sheet using a locking plate and two (optionally three) clamping shafts. The locking plate is specifically manufactured to match the tube hole pitch, ensuring perfect alignment for accurate and stable machining.



UNIVERSAL REACTION PLATE

The MicroDrill includes a locking plate and three shafts. The universal plate design allows the use of two shafts on one side for access to the last row of holes. The plate can also rotate 180 degrees to fit partition plates, channel heads, and other components.

AVAILABLE TOOLS



STWRPH

Weld removal head for tube plugs



WELDON 25

Drill bit holder for ER-25 collets



MPP-381

Manual tube plug puller up to 1-1/2" plugs



Tube Plugging

KRAIS SMART PLUGGING SYSTEM

➔ THE CHALLENGE

Traditional plugging of damaged tubes in heat exchangers and condensers requires maintaining expensive, extensive inventory. For every tube outer diameter (OD), you must stock separate plugs for every possible wall thickness (BWG). This ties up capital, consumes warehouse space, and delays reaction time during critical failures.

➔ THE NEW STANDARD

KRAIS changes the rules. We have developed a system based on precision reaming of the tube interior to a fixed, pre-defined dimension. Consequently, for a given tube diameter, you only need **one single plug size**, regardless of the tube's wall thickness (BWG).

➔ KEY BENEFITS

Inventory Reduction: instead of dozens of size variations, you stock only one plug type per tube diameter.

Instant Readiness: eliminate lead times for non-standard plug sizes during emergencies.

Cost Efficiency: reduced frozen capital and minimized risk of obsolete stock.

Reliability: precision surface preparation ensures a seal integrity that outperforms standard methods.

MINIMILL301 SPS

A compact, pneumatic machine designed for the precision reaming of tube ends. The system removes corrosion, deposits, and pitting, calibrating the Internal Diameter (ID) to perfectly match the universal KRAIS T_APPLE SPS plugs.

- ▶ **Durability:** Cutting heads manufactured from M2 high-speed steel or steel with 6% cobalt.
- ▶ **Reusability:** Tools can be resharpened multiple times, significantly lowering operational costs.
- ▶ **Performance Options:** Optional Oerlikon oxide coatings available for machining hard and exotic materials.



T_APPLE SPS PLUGS

Designed specifically for the KRAIS Smart Plugging System (SPS), this universal plug eliminates the need for gauge-specific sizing. By mating with the precision-reamed bore created by the MiniMill-301 SPS, a single plug size securely seals any wall thickness for a given tube outer diameter (OD)

- ▶ **Universal Compatibility:** Replaces gauge-specific plugs with one single item per Tube OD, drastically reducing inventory.
- ▶ **Torque-Controlled Installation:** Ensures consistent radial expansion without tube deformation.
- ▶ **Simplified Tooling:** Installs with a standard manual torque wrench; no hydraulic equipment required.
- ▶ **Engineered Reliability:** Delivers a secure seal capable of withstanding high thermal cycling and vibration.



WORKING RANGE		FEED STROKE		POWER	FREE SPEED	TORQUE	
APPLICATION RANGE	LOCKING RANGE						
12,4 – 25,4 mm	12,4 – 24,0 mm	25 mm	0,787»	1,3 HP	300 RPM	43 Nm	32 ft.lbs
0,488 – 1,000"	0,488 – 0,945"						
AIR USE		BODY WIDTH		BODY HEIGHT		BODY WEIGHT	
55 cfm	1,3 m ³ /min	2,32"	59 mm	13,1"	335 mm	15,4 Lbs	7 kg

SPS PLUGS SELECTION TABLE

Please measure your tube ID and select a proper material (XX): CS for Carbon Steel, BR for Admiralty Brass, SS for Stainless Steel, CN for Cu Nickel

TUBE OD		WALL	TUBE ID		PLUG NR	TOOL NR
[INCH]	[MM]	[BWG]	[INCH]	[MM]		
3/4"	19,05	18	0,652	16,56	SPS-1690-XX	SPST-1700
7/8"	22,22	18	0,777	19,74	SPS-2010-XX	SPST-2020
1"	25,4	18	0,902	22,91	SPS-2300-XX	SPST-2330

TOOL REAMING RANGE TABLE

Please check before order if your measured tube ID fits in tool reaming range.

TOOL NR	TUBE OD		BWG	[INCH]		[MM]		CUT LENGTH
	[INCH]	[MM]		MIN	MAX	MIN	MAX	
SPST-1700	3/4"	19,05	12-18	0,650	0,670	13,50	16-56	25 mm
SPST-2020	7/8"	22,22	12-18	0,780	0,800	16,60	19,74	25 mm
SPST-2330	1"	25,4	10-18	0,900	0,920	18,60	22,90	25 mm

AVAILABLE LOCKING JAWS

JAWS	RANGE [MM]		RANGE [INCH]		SPRING
	MIN	MAX	MIN	MAX	
201MM#36	12,40	14,50	0,488	0,571	DW-11
203 MM#36	13,90	16,00	0,547	0,630	DW-12,5
205 MM#36	15,90	18,00	0,626	0,709	DW-15,5
207 MM#36	16,90	19,00	0,665	0,748	
209 MM#36	18,90	21,00	0,744	0,827	
211 MM#36	19,90	22,00	0,783	0,866	
213 MM#36	20,90	23,00	0,823	0,906	
214 MM#36	21,90	24,00	0,862	0,944	

PROPER TORQUE



A torque wrench should be used to ensure correct plug installation.

EASY PLUG REMOVAL



A dedicated slide hammer, connected to the threaded part of the plug, allows safe extraction of the plug for tube inspection or replacement

SAFE PLUGGING PROCEDURE (STEP-BY-STEP)

1. MEASURE: use the **KRAIS Tube Hole Gauge** to precisely determine the tube condition and dimension prior to machining.
2. PRESSURE RELIEF (CRITICAL): before plugging, the tube must be pierced to relieve internal pressure. Use the **ORTCC (One Revolution Tube Cutter type C)**. This ensures operator safety and procedural compliance.
3. REAM: use the **MiniMill-301 SPS** to machine the tube interior to the required dimension.
4. PLUG: install the universal **KRAIS T_APPLE SPS** plug.

THE STARTER KIT INCLUDES:

- ▶ MiniMill-301 SPS Machine.
- ▶ One selected reaming tool (for 3/4", 7/8", or 1" tubes).

Additional tools available as options.

Universal plugs (SPS series) are sized and sold separately based on specific plant requirements.

FINFAN EXTENSION

To prepare tubes for SPS plugs in FinFan gas coolers, use the MiniMill 301 SPS with the optional 601-FINFAN-SPS-xx extension. The tool is mounted inside the tube, and an additional nut is used to stiffen and secure the assembly within the plug hole to ensure coaxial reaming.



TOOL	TUBE CAPACITY (OD)			BIT	CENTER NUT	JAWS COVER	
	[INCH]	[MM]	BWG			MIN	MAX
601-FINFAN-SPS-xx	1,000	25,40	12-16	SPS	1-1/8	207MM#36	213MM#36

AVAILABLE LENGTHS OF EXTENSION

MODEL	LENGTH	
	[MM]	[INCH]
601-FINFAN-SPS-6	152,4	6"
601-FINFAN-SPS-8	203,2	8"
601-FINFAN-SPS-10	254,0	10"
601-FINFAN-SPS-12	305,0	12"
601-FINFAN-SPS-14	355,6	14"
601-FINFAN-SPS-16	406,4	16"

Tube Plugs T_APPL HEP Series

High pressure plugs for general heat exchangers applications

The KRAIS T_APPL HEP series tube plugs are a specialized, mechanical plug engineered for use in a wide range of heat exchangers. Designed for high-pressure environments, it offers secure sealing without damaging the tube wall, even under severe thermal stress or vibration.

KEY ADVANTAGES

- ▶ Torque-controlled installation - ensures repeatable, consistent radial expansion with no tube deformation.
- ▶ Installation requires only a manual torque wrench. No high pressure pumps, no hydraulic oil leaks.
- ▶ Engineered expansion delivers a reliable mechanical seal, even under high thermal cycling and vibration.

PROPER TORQUE

EASY PLUG REMOVAL



A torque wrench should be used to ensure correct plug installation. Recommendation: T_APPL TW#100

A dedicated slide hammer, connected to the threaded part of the plug, allows safe extraction of the plug for tube inspection or replacement

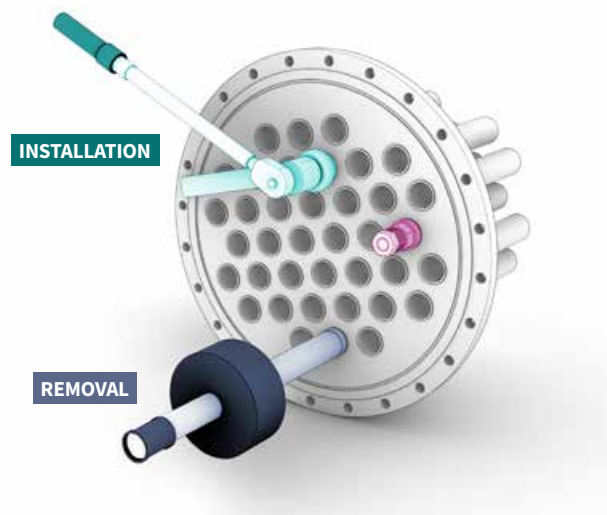

TOOL SELECTION TABLE

Please measure your tube ID and select a proper material (XX): CS for Carbon Steel, BR for Admiralty Brass, SS for Stainless Steel, CN for Cu Nickel

TUBE OD	WALL	TUBE ID		TOOL NR
[INCH]	[MM]	[BWG]	[INCH] [MM]	
5/8"	15,88	18	0,527 13,39	HEP-1351-XX
		19	0,541 13,74	HEP-1422-XX
		20	0,555 14,10	HEP-1483-XX
		21	0,561 14,25	
		22	0,569 14,45	
3/4"	19,05	12	0,532 13,51	HEP-1351-XX
		13	0,560 14,22	HEP-1422-XX
		14	0,584 14,83	HEP-1483-XX
		15	0,606 15,39	HEP-1539-XX
		16	0,620 15,75	
		17	0,634 16,10	HEP-1610-XX
		18	0,652 16,56	HEP-1656-XX
		19	0,666 16,92	HEP-1691-XX
		20	0,680 17,27	HEP-1762-XX
		21	0,686 17,42	
7/8"	22,22	12	0,657 16,69	HEP-1656-XX
		13	0,685 17,40	HEP-1762-XX
		14	0,709 18,01	HEP-1803-XX

TUBE OD	WALL	TUBE ID		TOOL NR
[INCH]	[MM]	[BWG]	[INCH] [MM]	
7/8"	22,22	15	0,731 18,57	HEP-1853-XX
		16	0,745 18,92	HEP-1892-XX
		17	0,759 19,28	
		18	0,777 19,74	HEP-1973-XX
		19	0,791 20,09	
		20	0,805 20,45	HEP-2044-XX
		21	0,811 20,60	HEP-2080-XX
		22	0,819 20,80	
1"	25,4	12	0,782 19,86	HEP-1973-XX
		13	0,810 20,57	HEP-2044-XX
		14	0,834 21,18	HEP-2184-XX
		15	0,856 21,74	HEP-2174-XX
		16	0,870 22,10	
		17	0,884 22,45	HEP-2245-XX
		18	0,902 22,91	HEP-2236-XX
		19	0,916 23,27	HEP-2326-XX
		20	0,930 23,62	
		21	0,963 24,46	HEP-2397-XX
		22	0,944 23,98	

TOOL EXPANSION RANGE TABLE

Please check before ordering if your measured ID fits within plugs range.

TOOL NR	[INCH]		[MM]	
	MIN	MAX	MIN	MAX
HEP-1351-XX	0,530	0,550	13,46	13,97
HEP-1422-XX	0,550	0,570	13,97	14,48
HEP-1483-XX	0,570	0,590	14,48	14,99
HEP-1539-XX	0,610	0,630	15,49	16,00
HEP-1610-XX	0,630	0,650	16,00	16,51
HEP-1656-XX	0,650	0,670	16,51	17,02
HEP-1691-XX	0,670	0,690	17,02	17,53
HEP-1762-XX	0,690	0,710	17,53	18,03
HEP-1803-XX	0,710	0,730	18,03	18,54
HEP-1853-XX	0,730	0,750	18,54	19,05
HEP-1892-XX	0,750	0,770	19,05	19,56
HEP-1973-XX	0,780	0,800	19,81	20,32
HEP-2044-XX	0,800	0,820	20,32	20,83
HEP-2080-XX	0,820	0,840	20,83	21,34
HEP-2184-XX	0,840	0,860	21,34	21,84
HEP-2174-XX	0,860	0,880	21,84	22,35
HEP-2245-XX	0,880	0,900	22,35	22,86
HEP-2236-XX	0,900	0,920	22,86	23,37
HEP-2326-XX	0,920	0,940	23,37	23,88
HEP-2397-XX	0,940	0,960	23,88	24,38

Tube Plugs T_APPL FFP Series

High pressure plugs for applications in fin fan air-cooled heat exchangers (ACHE)

The KRAIS T_APPL FFP series tube plugs are a specialized, mechanical plug engineered for use in air-cooled fin fan heat exchangers. Designed for high-pressure environments, it offers secure sealing without damaging the tube wall, even under severe thermal stress or vibration. Unlike general-purpose plugs, the T_APPL is designed for difficult-to-reach tube sheet locations, especially where compact water box openings and restricted visibility are common.

KEY ADVANTAGES

- ▶ Torque-controlled installation - ensures repeatable, consistent radial expansion with no tube deformation.
- ▶ Installation requires only a manual torque wrench. No high pressure pumps, no hydraulic oil leaks.
- ▶ The long-reach Push-in Spanner enables easy access in deep or narrow configurations in fin fan systems.
- ▶ Engineered expansion delivers a reliable mechanical seal, even under high thermal cycling and vibration.



PROPER TORQUE



A torque wrench should be used to ensure correct plug installation - only precise torque application can achieve reliable and leak-tight tube sealing. Recommendation: T_APPL TW#100

EASY PLUG REMOVAL



A dedicated slide hammer, connected to the threaded part of the plug, allows safe extraction of the plug for tube inspection or replacement

PUSH-IN SPANNER

A specially designed installation tool precisely positions the T_APPL plug and presses it into the tube to ensure proper sealing. This solution is tailored for fin fan heat exchangers, where access is limited, visibility is poor, and tool reach must exceed standard dimensions.

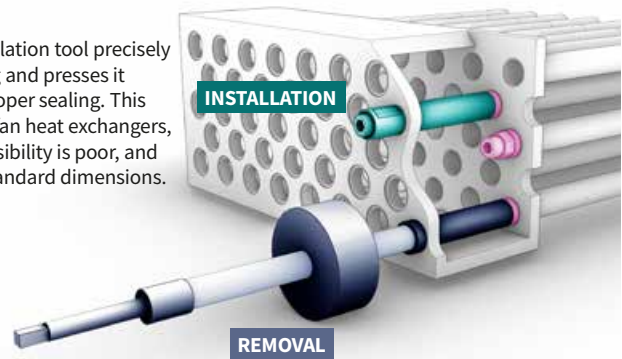

TOOL SELECTION TABLE

Please measure your tube ID and select a proper material (XX): CS for Carbon Steel, BR for Admiralty Brass, SS for Stainless Steel, CN for Cu Nickel

TUBE OD		WALL		TUBE ID		TOOL NR
[INCH]	[MM]	[BWG]	[INCH]	[MM]		
7/8"	22,22	15	0,731	18,57	FFP-1853-xx	
		16	0,745	18,92	FFP-1892-xx	
		17	0,759	19,28		
		18	0,777	19,74	FFP-1973-xx	
		19	0,791	20,09		
		20	0,805	20,45	FFP-2044-xx	
		21	0,811	20,60	FFP-2080-xx	
		22	0,819	20,80		

TUBE OD		WALL		TUBE ID		TOOL NR
[INCH]	[MM]	[BWG]	[INCH]	[MM]		
1"	25,4	10	0,732	18,59	FFP-1853-xx	
		11	0,760	19,30	FFP-1892-xx	
		12	0,782	19,86	FFP-1973-xx	
		13	0,810	20,57	FFP-2044-xx	
		14	0,834	21,18	FFP-2184-xx	
		15	0,856	21,74	FFP-2174-xx	
		16	0,870	22,10		
		17	0,884	22,45	FFP-2245-xx	
		18	0,902	22,91	FFP-2236-xx	
		19	0,916	23,27	FFP-2326-xx	
		20	0,930	23,62		

TOOL EXPANSION RANGE TABLE

Please check before order if your measured ID fits within plugs range.

TOOL NR	[INCH]		[MM]	
	MIN	MAX	MIN	MAX
FFP-1853-XX	0,730	0,750	18,54	19,05
FFP-1892-XX	0,750	0,770	19,05	19,56
FFP-1973-XX	0,780	0,800	19,81	20,32
FFP-2044-XX	0,800	0,820	20,32	20,83
FFP-2080-XX	0,820	0,840	20,83	21,34
FFP-2184-XX	0,840	0,860	21,34	21,84
FFP-2174-XX	0,860	0,880	21,84	22,35
FFP-2245-XX	0,880	0,900	22,35	22,86
FFP-2236-XX	0,900	0,920	22,86	23,37
FFP-2326-XX	0,920	0,940	23,37	23,88
FFP-2397-XX	0,940	0,960	23,88	24,38

Essential 4-step tube plugging protocol

Precision tools for guaranteed sealing performance

STEP 1: LEAK DETECTION

▶ KVLD-3000 vacuum leak tester

The KVLD-3000 delivers immediate leak identification through compressed air vacuum testing—steady gauge readings confirm tube integrity, pressure drops pinpoint failure locations requiring T_APPL intervention. Using compressed air, it creates a vacuum inside the tube—if the gauge reading holds steady, the tube is intact; a drop indicates a leak.

STEP 2: TUBE VENTILATION

▶ ORTC one revolution tube cutter

Unventilated tubes create projectile hazards during plug removal. ORTC's eccentric cutting principle delivers tube puncturing with quarter-turn rotation for ventilation, eliminating this risk. Full revolution cuts the tube completely. Standard adjustable length 1"-6" (25-155mm), extended reach available in 10" (254mm) increments. Hand or ratchet wrench operation only. ORTCC version C specifically engineered for heavy-wall carbon steel tube ventilation, available in 6" and 12" lengths.

STEP 3: SURFACE PREPARATION

▶ Coarse wire brush cleaning

Contaminated surfaces compromise plug performance. Aggressive wire brush cleaning removes deposits, corrosion, and debris – creating the clean substrate essential for reliable T_APPL sealing under operational pressure.

STEP 4: PRECISION PREPARATION

▶ MiniDrill-500-WTRT-AC (when required)

When standard cleaning proves insufficient, the MiniDrill-500-WTRT-AC delivers controlled tube wall reduction across demanding materials – carbon steel to Inconel alloys. Perfect for preparing tubes before T_APPL plugging, effectively removing rust, scale, and deposits to ensure clean, secure sealing.

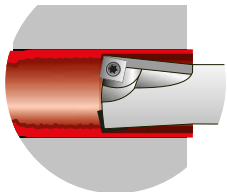
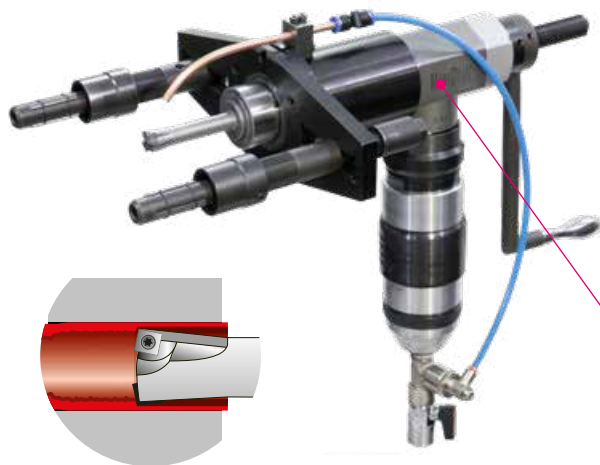
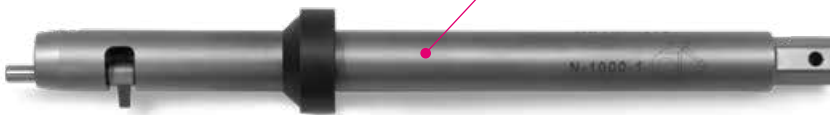

Tube plugs



KRAIS TUBE HOLE GAUGE K200

Choosing the correct plug size is essential for optimal performance, reliability, and safety of KRAIS tube plugs. Use the detailed sizing chart to determine the appropriate plug dimensions, ensuring compatibility and precise fitting within your specific tubing system and operational requirements



ORTCC - ONE REVOLUTION TUBE CUTTER VERSION C

One Revolution Tube Cutter version C is used for piercing heavy wall, carbon steel tubes for ventilation prior to plugging the leaky tubes. Delivered in two length version 6" and 12".

One piece tube plugs

TUBE OD		TUBE GAUGE	A		B		TUBE PLUG
[INCH]	[MM]		[INCH]	[MM]	[INCH]	[MM]	
3/8	9,5	15-22	0,176	4,47	0.388	9,86	TP-1-**
1/2	12,7	11-14	0,176	4,48	0.388	9,87	TP-1-**
		15-22	0,301	7,65	0,513	13,00	TP-2-**
5/8	15,8	11-14	0,301	7,66	0,513	13,01	TP-2-**
		15-22	0,426	10,82	0,638	16,20	TP-3-**
3/4	19,05	11-14	0,426	10,83	0,638	16,21	TP-3-**
		15-22	0,551	14,00	0,763	19,38	TP-4-**
7/8	22,22	11-14	0,551	14,01	0,763	19,39	TP-4-**
		15-22	0,676	17,17	0,888	22,56	TP-5-**
1	25,4	11-14	0,676	17,18	0,888	22,57	TP-5-**
		15-22	0,801	20,35	1,013	25,73	TP-6-**
1-1/8	28,6	11-14	0,801	20,36	1,013	25,74	TP-6-**
		15-22	0,926	23,52	1,138	28,9	TP-7-**
1-1/4	31,7	11-14	0,926	23,53	1,138	28,10	TP-7-**
		15-22	1,015	25,78	1,263	32,08	TP-8-**
1-3/8	34,9	11-14	1,015	25,79	1,263	32,09	TP-8-**
		15-22	1,176	29,87	1,388	35,87	TP-9-**
1-1/2	38,1	11-14	1,176	29,88	1,388	35,88	TP-9-**
		15-22	1,301	32,66	1,513	38,93	TP-10-**

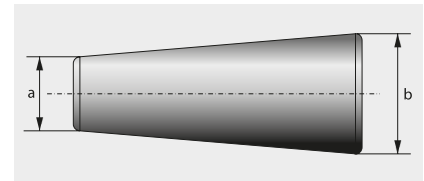

** SPECIFY MATERIAL:

- AL for Aluminium
- S for Steel
- SS for Stainless Steel
- B for Brass
- M for Monel

The image shows a close-up of industrial machinery, likely a heat exchanger or a similar process unit. It features a large metal structure with a prominent grid of bolts on its side. Several pipes are connected to the unit, some with flanges and valves. The background shows a blue sky and a body of water, suggesting an outdoor industrial setting.

FinFan Applications

MiniDrill GFF

The **MiniDrill GFF** is a dedicated machining solution specifically developed for **FinFan air coolers**, enabling fast and precise repair of plug threads and sealing surfaces directly on-site.

Engineered for **FinFan maintenance**, the system supports drilling, re-machining, and seat restoration operations with a single machine, changing only the tool, eliminating the need for disassembly. Its rigid, torque-reactive design and dual clamping arms ensure stable mounting on adjacent tube holes, allowing accurate alignment across typical FinFan tube layouts.

With an **80 mm stroke**, controlled speed, and high torque output, the MiniDrill GFF delivers reliable performance even in demanding field conditions. The result is repeatable machining accuracy, reduced downtime, and restored sealing integrity of critical FinFan connections.

A compact, robust, and purpose-built tool for efficient FinFan thread repair and maintenance operations.



WORKING RANGE		LOCKING RANGE	WORKING STROKE	FREE SPEED	POWER	TORQUE	
12,5– 51,0 mm		According to the drawing	80 mm	100 Rpm	1,3 Hp	140 Nm	
0,492 – 2,000"			3,150"			105 Ft.Lbs	
AIR USE		BODY WIDTH		BODY HEIGHT		BODY WEIGHT	
55 cfm	1,3 m3/min	2,32"	59 mm	13,1"	335 mm	17,5 Lbs	8 kg



RIGID LOCKING

On standard FinFan gas coolers machine locks onto two shafts on the adjacent holes. The locking plate is manufactured according to the tube hole pitch to ensure precise tool alignment.

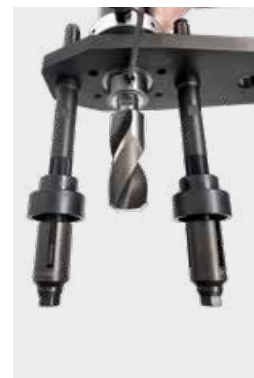

UNIVERSAL REACTION PLATE

MiniDrill FinFan is delivered with locking plate and 2 reaction shafts. Construction of the plate allows for locking machine with both shafts on one side to allow to machine the last holes in the row. Plate can be etc.

FINFAN THREAD REPAIR PROCESS

PROPER MACHINE LOCKING FOR ALL STEPS

Choose the correct locking jaws to suit the existing plug holes



PLUG SIZE		JAW SET (2 REQUIRED)	
1-1/8"	28,58 mm	12 TPI	701MM #36-1-1/8-GFF
1-1/4"	31,75 mm	12 TPI	703MM #36-1-1/4-GFF
1-3/8"	34,93 mm	12 TPI	705MM #36-1-3/8-GFF
1-1/2"	38,10 mm	12 TPI	707MM #36-1-1/2-GFF
1-5/8"	41,28 mm	12 TPI	709MM #36-1-5/8-GFF
1-3/4"	44,45 mm	12 TPI	711MM #36-1-3/4-GFF
1-7/8"	47,63 mm	12 TPI	713MM #36-1-7/8-GFF

STEP 1 // Heads for weld removal over the welded plugs (in case are welded)



PLUGS SIZE	HEAD	INSERT	SCREW
1-1/8"	28,58 mm 12 TPI	TFWR-GFF-350	CS-5D MHS-4
1-1/4"	31,75 mm 12 TPI	TFWR-GFF-380	CS-5D MHS-4
1-3/8"	34,93 mm 12 TPI	TFWR-GFF-410	CS-5D MHS-4
1-1/2"	38,10 mm 12 TPI	TFWR-GFF-440	CS-5D MHS-4
1-5/8"	41,28 mm 12 TPI	TFWR-GFF-470	CS-5D MHS-4
1-3/4"	44,45 mm 12 TPI	TFWR-GFF-500	CS-5D MHS-4
1-7/8"	47,63 mm 12 TPI	TFWR-GFF-540	CS-5D MHS-4

STEP 2 // Select the appropriate size drill head to match the desired new thread size



DRILL HEAD SIZE	DRILL HEAD	INSERT	SCREW
1-1/8 to 1-1/4"	28,58 to 31,75 mm	MD-29,6-DRILL-L-130	CS-0.4 MHS-4
1-1/4 to 1-3/8"	31,74 to 34,93 mm	MD-32,9-DRILL-L-130	CS-0.4 MHS-4
1-3/8 to 1-1/2"	34,93 to 38,10 mm	MD-36,1-DRILL-L-130	CS-0.4 MHS-4
1-1/2 to 1-5/8"	38,10 to 41,28 mm	MD-39,3-DRILL-L-130	CS-0.4 MHS-4
1-5/8 to 1-3/4"	41,28 to 44,45 mm	MD-42,5-DRILL-L-130	CS-0.4 MHS-4
1-3/4 to 1-7/8"	44,45 to 47,63 mm	MD-45,5-DRILL-L-130	CS-0.4 MHS-4

STEP 3 // Select the chamfering head to chamfer the hole before tapping (heads need a Weldon flange: MD-FLANGE-STWRMH)



RANGE	HEAD	INSERT	SCREW
0,787 to 1,653"	20,00 to 42,00 mm	STWRMH-317	WRI MHS-4
1,417 to 2,244"	36,00 to 57,00 mm	STWRMH-444	CDI MHS-4

STEP 4 // Select tapping head to suit the required thred size



PLUGS THREAD SIZE	TAP HEAD	RATCHED FEED ARM	
1-1/8"	28,58 mm 12 TPI	MDFFPT-1-1/8_12	MD-RS-H28
1-1/4"	31,75 mm 12 TPI	MDFFPT-1-1/4_12	MD-RS-H28
1-3/8"	34,93 mm 12 TPI	MDFFPT-1-3/8_12	MD-RS-H28
1-1/2"	38,10 mm 12 TPI	MDFFPT-1-1/2_12	MD-RS-H28
1-5/8"	41,28 mm 12 TPI	MDFFPT-1-5/8_12	MD-RS-H28
1-3/4"	44,45 mm 12 TPI	MDFFPT-1-3/4_12	MD-RS-H28
1-7/8"	47,63 mm 12 TPI	MDFFPT-1-7/8_12	MD-RS-H28

STEP 5

Produce new gasket seat using MiniMill-300GFF. Choose heads and jaws on next page.



MiniMill 300GFF

Ideal for gasket seat machining of any size of fin fan cooler. A standard machine is equipped with a cutter head and a special locking system to fit your application. The machine locks directly into the plug thread.

STANDARD SET UP

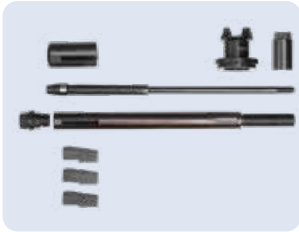

GASKET FINFAN SET

Supplied with 20 mm shaft, one set of jaws to suit plug thread diameter, pilot and gasket seat milling head. Plug size details must be provided by customer with order.



Custom machined jaws. Showing locked and up-locked position.



STANDARD WORKING RANGE		FEED STROKE	FREE SPEED	POWER	TORQUE		
APPLICATION RANGE (ID-OD)	LOCKING RANGE (ID)						
12 TPI	Suit to thread of the plug	20 mm	300 Rpm	1,3 Hp	43 Nm		
1,125 - 2,125"		0,787"			32 Ft.Lbs		
AIR USE		BODY WIDTH		BODY HEIGHT		BODY WEIGHT	
55 cfm	1,3 m ³ /min	2,32"	59 mm	13,1"	335 mm	13,2Lbs	6 kg

EXAMPLE TOOL APPLICATION



FinFan cooler before a maintenance



Plug hole before re machining the gasket seat



Safely re-machine gasket surfaces in seconds.



All types of water box materials can be machined with the carbide inserts of the MiniMill 300 GFF.

MiniMill 300GFF

GASKET SEAT FACING HEADS AND JAWS NUMBERS

HEAD TYPE	PLUG SIZE			SEAL NEST DIAMETER				INSERT	NO. OF INSERTS	JAWS SET NUMBER	PLUG SIZE		TPI	PILOT
	[INCH]	[MM]	TPI	MIN [INCH]	MAX [INCH]	MIN [MM]	MAX [MM]				[INCH]	[MM]		
FFGSMH-1125	1,125	28,58	12	0,940	1,496	24,00	38,00	CI 5x5	4	701MM #36-1-1/8-GFF	1,125	28,575	12	PGFF-1125
FFGSMH-1250	1,250	31,75	12	1,063	1,614	27,00	41,00	CI 5x5	4	703MM #36-1-1/4-GFF	1,250	31,750	12	PGFF-1250
FFGSMH-1350	1,375	34,93	12	1,220	1,772	31,00	45,00	CI 5x5	4	705MM #36-1-3/8-GFF	1,375	34,925	12	PGFF-1350
FFGSMH-1500	1,500	38,10	12	1,339	1,890	34,00	48,00	CI 5x5	4	707MM #36-1-1/2-GFF	1,500	38,100	12	PGFF-1500
FFGSMH-1625	1,625	41,27	12	1,457	2,008	37,00	51,00	CI 5x5	4	709MM #36-1-5/8-GFF	1,625	41,275	12	PGFF-1625
FFGSMH-1750	1,750	44,45	12	1,590	2,140	40,40	54,40	CI 5x5	4	711MM #36-1-3/4-GFF	1,750	44,450	12	PGFF-1750
FFGSMH-1875	1,875	47,62	12	1,720	2,270	43,60	57,60	CI 5x5	4	713MM #36-1-7/8-GFF	1,875	47,625	12	PGFF-1875

Other sizes on request. If plug holes are damaged beyond repair, our MiniDrill 55 can be used to upsize them to the next size. Example - 1-1/8" to 1-3/8".

Seal nest diameter diagram

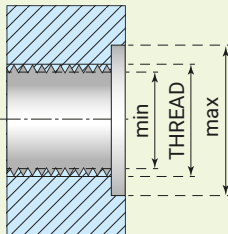

OTHER OPTIONAL ACCESSORIES



FAST CLAMPING SYSTEM

System offers rapid tube to tube cycle time, increased productivity (up to 4x) with little operator fatigue. Ideal for large amount of end preps.

MiniMill 300FF

The MiniMill 300FF is a pneumatic tube facing machine engineered for professional maintenance and repair of fin fan gas coolers and air-cooled heat exchangers. Compact, robust, and built for demanding industrial environments, it delivers consistent results across the entire tube sheet with a cycle time of approx. 1 min per tube.



All FinFan attachments feature an extended-reach shaft design, allowing the cutting head to access tube ends recessed deep within the tube sheet. The distance between the plug thread engagement point and the cutting zone is fully accommodated, enabling reliable machining without contact with the surrounding structure.



APPLICATION RANGE (ID-OD)		LOCKING RANGE	FEED STROKE	POWER	FREE SPEED	TORQUE	
12,5– 51,0 mm		According to the drawing	20 mm	1,3 Hp	300 Rpm	43 Nm / 32 Ft.Lbs	
0,492 – 2,000"			0,787"		100 Rpm	120 Nm / 88,5 Ft.Lbs	
AIR USE		BODY WIDTH		BODY HEIGHT		BODY WEIGHT	
55 cfm	1,3 m ³ /min	2,32"	59 mm	13,1"	335 mm	13,2Lbs	6 kg

OPTIONAL ACCESSORIES



SPEED REDUCER

Easy to use gearbox for 3x speed reduction. Increases the torque, enabling the machine to generate a thick chip whilst reducing the cutting time.



RATCHET FEED

Feed system allowing to work in narrow and tight locations, eg. in water walls.



LEVER FEED

Quick and easy feed system. Used in many basic applications.

EXAMPLE TOOL APPLICATION



The machine is designed for work on gas coolers: an elongated special head and a nut fixing the tool in the socket.



The bit edge covers the entire weld to be removed



Removal of the weld ends with a visible groove between the tube and the tube sheet.



MiniMill 300FF

FINFAN ATTACHMENT FOR FACING TUBES (DEFAULT)

Attachment for facing tube ends in fin fan gas coolers. Features an adjustable-length locking shaft and a support bushing that threads into the plug, ensuring precise, repeatable positioning from tube to tube. Cycle time: approx. 1 min per tube. Recommended machine speed: 300 RPM.



TOOL	TUBE CAPACITY (OD)			BIT	CENTER NUT	JAWS COVER	
	[INCH]	[MM]	BWG			MIN	MAX
597-FINFAN-CSS-12	0,750	19,05	12-18	CSZ	7/8	307MM#36	313MM#36
600-FINFAN-CSS-12	0,875	22,23	12-18	CSZ	1	316MM#36	319MM#36
601-FINFAN-CSS-12	1,000	25,40	12-23	CSS	1-1/8	207MM#36	213MM#36
603-FINFAN-CSS-12	1,125	28,58	12-23	CSS	1-1/4	211MM#36	217MM#36
605-FINFAN-CSS-12	1,250	31,75	11-23	CSS	1-3/8	103MM#36	107MM#36
607-FINFAN-CSS-12	1,500	38,10	11-23	CS	1-5/8	107MM#36	111MM#36
609-FINFAN-CSS-12	1,750	44,45	9-23	CS	1-7/8	111MM#36	115MM#36
611-FINFAN-CSS-12	2,000	50,80	9-23	CS	2-1/8	115MM#36	119MM#36

FINFAN SEAL WELD REMOVAL ATTACHMENT

Attachment for seal weld removal in air-cooled heat exchangers. The adjustable-length locking shaft and support bushing thread into the plug for secure, consistent engagement. Cycle time: approx. 1 min per tube. Recommended machine speed: 100 RPM.



TOOL	TUBE CAPACITY (OD)			BIT	CENTER NUT	JAWS COVER	
	[INCH]	[MM]	BWG			MIN	MAX
597-FINFAN-SWR-12	0,750	19,05	12-18	CSZ	7/8	307MM#36	313MM#36
600-FINFAN-SWR-12	0,875	22,23	12-18	CSZ	1	316MM#36	319MM#36
601-FINFAN-SWR-12	1,000	25,40	12-23	CSS	1-1/8	207MM#36	213MM#36
603-FINFAN-SWR-12	1,125	28,58	12-23	CSS	1-1/4	211MM#36	217MM#36
605-FINFAN-SWR-12	1,250	31,75	11-23	CS	1-3/8	103MM#36	107MM#36
607-FINFAN-SWR-12	1,500	38,10	11-23	CS	1-5/8	107MM#36	111MM#36
609-FINFAN-SWR-12	1,750	44,45	9-23	CS	1-7/8	111MM#36	115MM#36
611-FINFAN-SWR-12	2,000	50,80	9-23	CS	2-1/8	115MM#36	119MM#36

FINFAN CHAMFERING ATTACHMENT

Attachment for chamfering tube sheet holes in fin fan units prior to welding. Features an adjustable-length locking shaft and a support bushing that threads into the plug. Cycle time: approx. 1 min per tube. Recommended machine speed: 300 RPM.



TOOL	TUBE CAPACITY (OD)			BIT	CENTER NUT	JAWS COVER	
	[INCH]	[MM]	BWG			MIN	MAX
601-FINFAN-CMF-12	1,000	25,40	12-23	CI-6x6	1-1/8	207MM#36	213MM#36
605-FINFAN-CMF-12	1,250	31,75	11-23	CI-6x6	1-3/8	103MM#36	107MM#36
607-FINFAN-CMF-12	1,500	38,10	11-23	CI-6x6	1-5/8	107MM#36	111MM#36

FINFAN JPREP ATTACHMENT

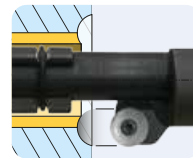

Attachment for simultaneous facing of tube ends and tube sheet surfaces in fin fan units. The specially shaped head carries a large round cutting insert, enabling full coverage of the weld area in a single pass. Recommended machine speed: 100 RPM.



TOOL	TUBE CAPACITY (OD)			INSERT	CENTER NUT	JAWS COVER	
	[INCH]	[MM]	BWG			MIN	MAX
601-FF-JPREP-12"	1,000	25,40	12-23	O10-Co	1-1/8	207MM#36	213MM#36
603-FF-JPREP-12"	1,125	28,58	12-23	O10-Co	1-1/4	211MM#36	217MM#36
605-FF-JPREP-12"	1,250	31,75	11-23	O10-Co	1-3/8	215MM#36	219MM#36
607-FF-JPREP-12"	1,500	38,10	11-23	O10-Co	1-5/8	107MM#36	111MM#36
609-FF-JPREP-12"	1,750	44,45	9-23	O10-Co	1-7/8	111MM#36	115MM#36
611-FF-JPREP-12"	2,000	50,80	9-23	O10-Co	2-1/8	115MM#36	119MM#36

LENGTHS AVAILABLE ON REQUEST

MODEL	LENGTH	
	[MM]	[INCH]
xxx-FINFAN-6	152,4	6"
xxx-FINFAN-8	203,2	8"
xxx-FINFAN-10	254,0	10"
xxx-FINFAN-12	305,0	12"
xxx-FINFAN-14	355,6	14"
xxx-FINFAN-16	406,4	16"

FinMill

KRAIS FinMill is a air powered tool designed for removing fin from the outside diameter of a tube. The tool is based on the same quality drive and housing as our other PrepMill series tools. Thanks to heavy duty locking system The FinMill fin tube removal tool clamps reliably in the tube and offers chatter-free work at any position.

STANDARD SET UP



DOUBLE SIDE HEAD
Special shaped head, allows to remove left- and right-handed fins.



SHAFT25
Self-align, heavy duty locking system. Shafts and jaws are longer and wider to ensure maximum clamping force.

OPTIONAL



STAR WHEEL
The most precise feed system. Used in many basic and demanding applications.



Reversible motor allow to work and remove left and right hand fins.

STANDARD WORKING RANGE		FEED STROKE	FREE SPEED	POWER	TORQUE		
APPLICATION RANGE (ID-OD)	LOCKING RANGE (ID)						
31,75 - 63,50 mm	25 - 122 mm	100 mm	100 Rpm	2,2 Hp	370 Nm		
1-1/4" - 2-1/2"	0,984 - 4,803"	4"			277 Ft.Lbs		
AIR USE		BODY WIDTH		BODY HEIGHT		BODY WEIGHT	
75 cfm	2,2 m ³ /min	2,59"	66 mm	14,5"	370 mm	19 Lbs	9 kg

HEAD NUMBERS

RANGE		HEAD
[INCH]	[MM]	
1-1/4	31,75	FMRH-317
1-1/2	38,10	FMRH-381
1-3/4	44,45	FMRH-444
2	50,80	FMRH-508
2-1/4	57,15	FMRH-571
2-1/2	63,50	FMRH-635

LOCKING RANGES WITH SHAFT25

RANGE [MM]		RANGE [INCH]		JAWS	SPRING	
MIN	MAX	MIN	MAX		NR	QTY.
25	30	0,984	1,181	NS-1	SP-24	1
30	35	1,181	1,378	NS-2	SP-24	1
35	40	1,378	1,575	NS-3	SP-25	2
40	45	1,575	1,772	NS-4	SP-25	2
45	50	1,772	1,969	NS-5	SP-25	2
50	55	1,969	2,165	NS-6	SP-25	2
55	60	2,165	2,362	NS-7	SP-25	2
60	65	2,362	2,559	NS-8	SP-25	2

EXAMPLE TOOL APPLICATION



Removes 4.0" (101 mm) depth of fin from the tube OD in less than 2 minutes



FINMILL E

Electric version of tool - covers the same pipe sizes and comes with the same cutting head. Electric motor made by Makita with 3 stage planetary gear box made by KRAIS has variable speed control and produce solid torque. Drive is interchangeable with pneumatic drive and can be purchased separately at any time.

Free Speed..... 115 RPM
 Power..... 750 W
 Torque..... 366 NM (280 Ft.Lbs)
 Feed Stroke 20 mm (0,787")
 FinMill E works only with right hand fins.



Tube Beveling Machines

Ranges for ID/OD mount bevelers

HOW TO READ IT

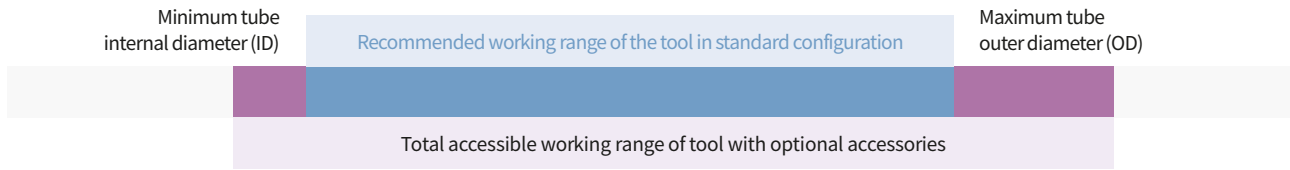

MILL SERIE WORKING RANGES (UNIVERSAL TOOLS)

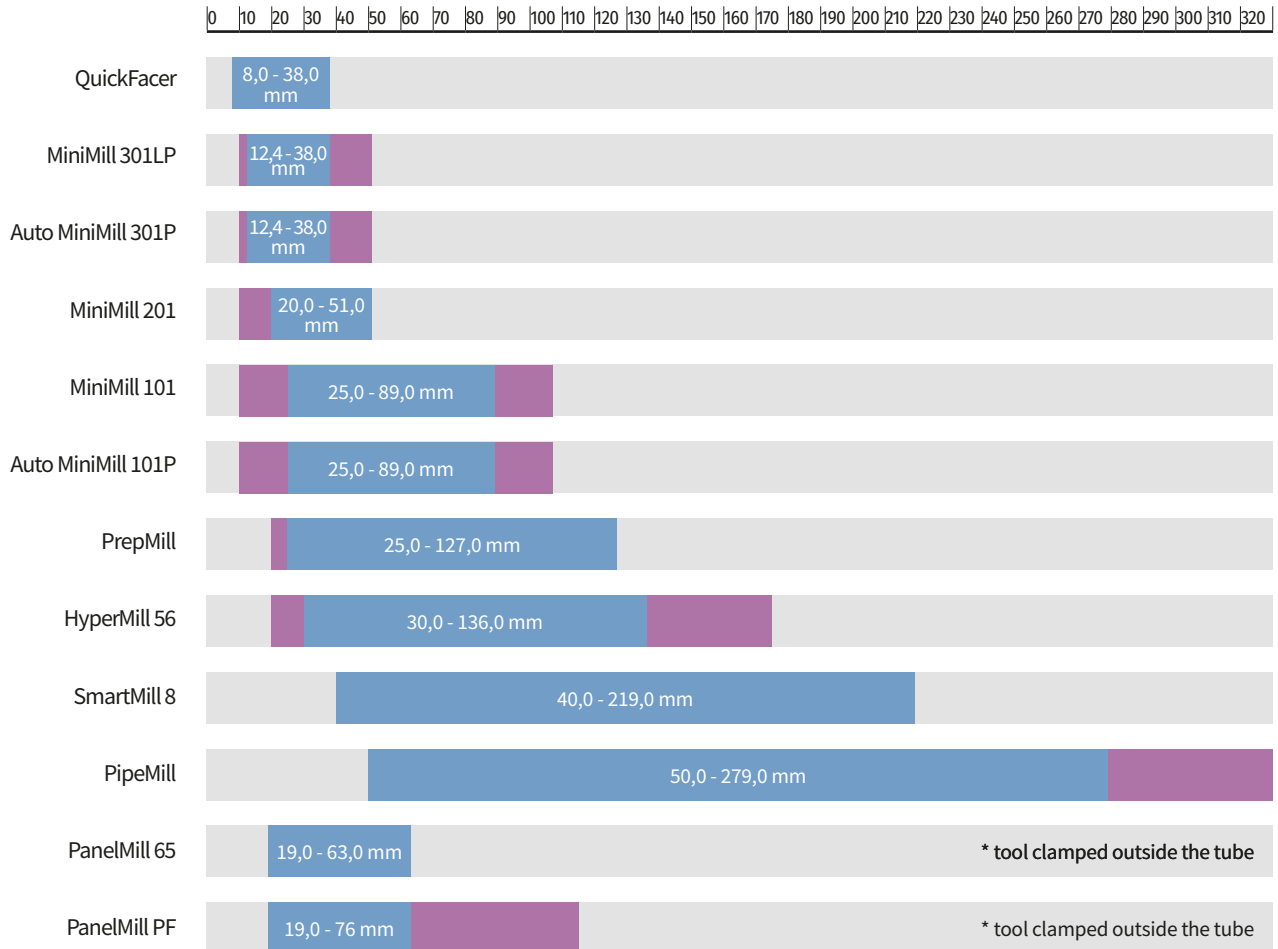

LATHE SERIE WORKING RANGES (UNIVERSAL TOOLS)

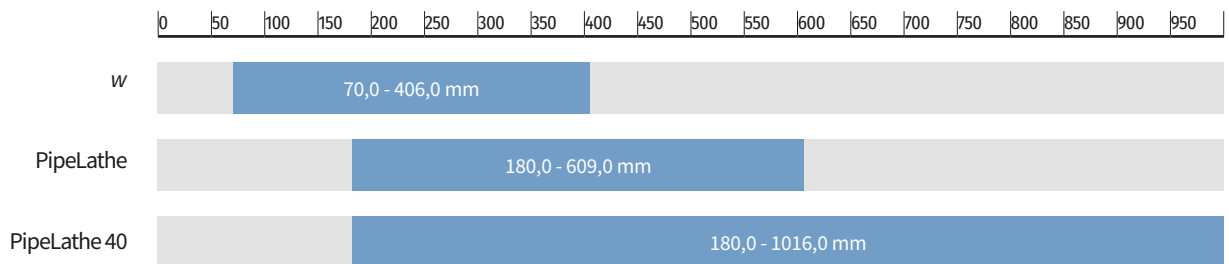

ID beveling machines proper lock

FOR: MINIMILL 101, MINIMILL 201, MINIMILL 301LP AND AUTO MINIMILL WITH MINISHAFT.

In order to obtain the best possible centring of the MiniMill into the faced, bevel or weld removal tube, we recommend to select the shaft with diameter closest possible to the inner diameter of tube.

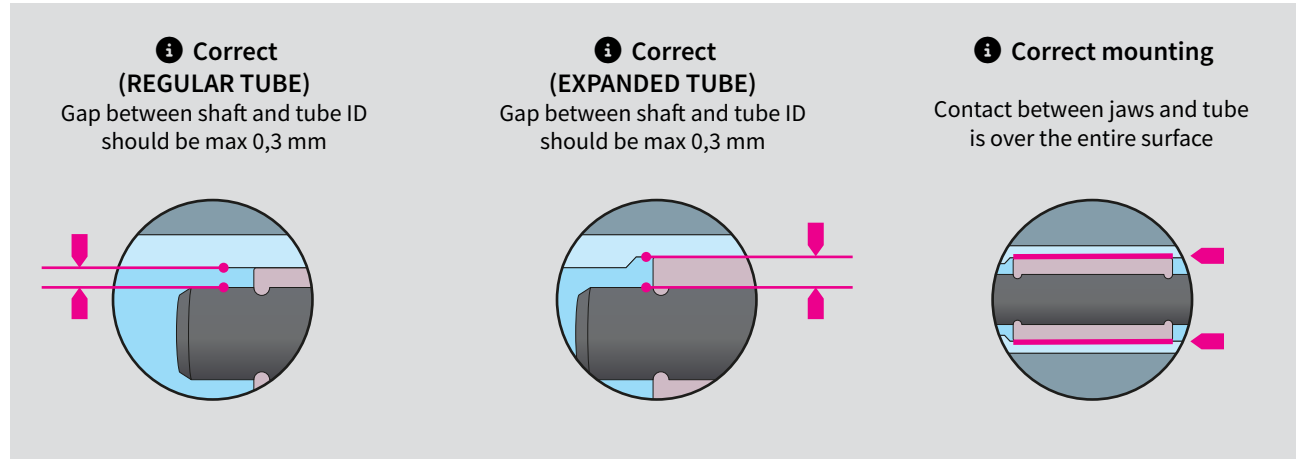

✘ WRONG JAWS SETUP

✔ CORRECT JAWS SETUP

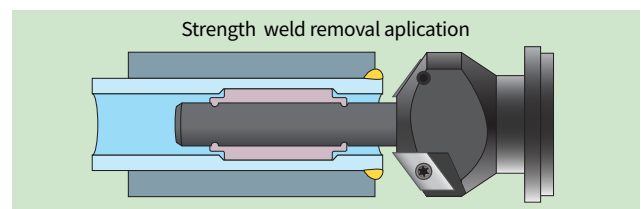
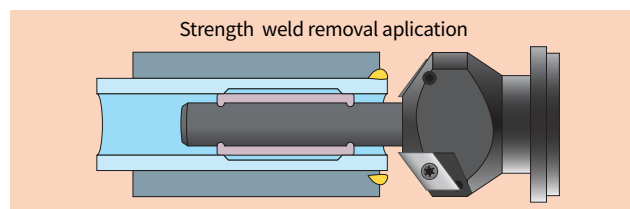
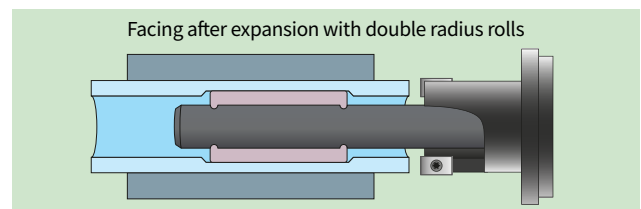
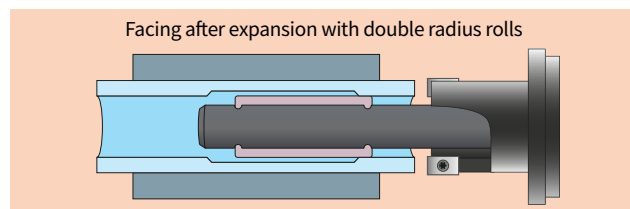
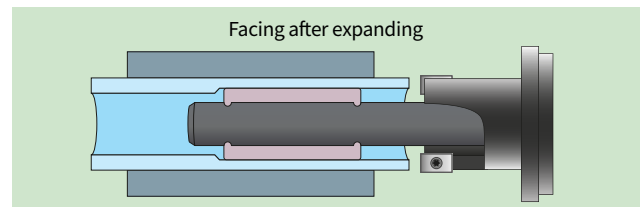
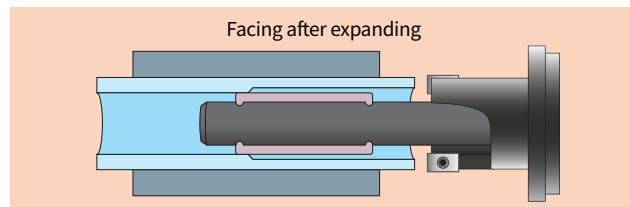
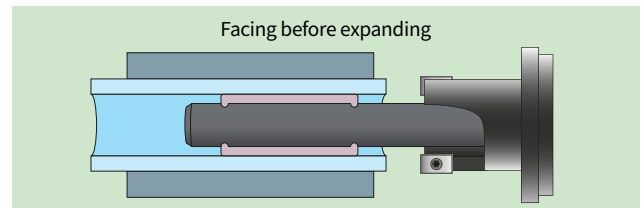
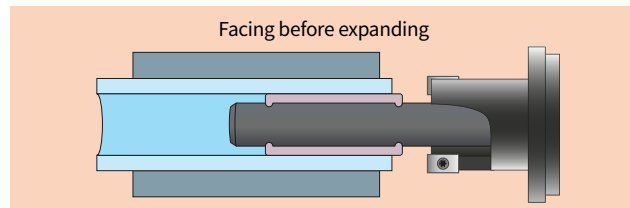

Locking jaws selection for Minimill & HyperMill

Selecting the appropriate clamping system is critical for ensuring machining precision and operator safety. KRAIS provides specialized shaft configurations designed to match specific tube diameters and torque requirements.

Each machine is delivered with a selected clamping set only, which is specified on the machines pages in the catalog. Below we present the full available range of jaws for each clamping system to facilitate jaw selection for specific customer needs.

MICROSHAFT AND MINISHAFT SYSTEMS

These systems utilize interchangeable guide shafts designed for high-precision applications in small-diameter tubing. They provide a stable pilot for the bevelling head, ensuring concentricity during the machining process.

MICROSHAFT SYSTEM

Engineered for extremely restricted access and small-bore applications. This system uses a set of interchangeable shafts to cover an internal diameter (ID) range from 9,0 mm to 15,0 mm. It is the primary choice for thin-walled heat exchanger tubes where precise alignment is mandatory.

MINISHAFT SYSTEM

A versatile centering system for standard small-to-medium tube sizes. It utilizes reinforced interchangeable shafts to cover an ID range of 12,4 mm to 48,0 mm. The system maintains a low profile while providing sufficient rigidity for consistent weld prep geometry.

JAWS FOR MICROSHAFT



MICROSHAFT can be used with:
MiniMill 101, MiniMill 201,
MiniMill 301

	RANGE [MM]		RANGE [INCH]		JAWS	SHAFT	PIN	CAGE SIZE		SPRING
	MIN	MAX	MIN	MAX				[INCH]	[MM]	
STANDARD	9,00	10,00	0,354	0,394	301MM#36	800MM#151	MS-158-51	0,354	9,00	DW-7,5
	10,00	11,00	0,394	0,433	301MM#36	801MM#151		0,394	10,00	DW-8,5
	11,00	12,00	0,433	0,472	303MM#36					
	12,00	13,00	0,472	0,512	305MM#36	MS-158				
	13,00	14,00	0,512	0,551	307MM#36	805MM#151		0,453	11,50	DW-10
14,00	15,00	0,551	0,591	309MM#36						

JAWS FOR MINISHAFT



MINISHAFT can be used with:
MiniMill 101, MiniMill 201,
MiniMill 301

	RANGE [MM]		RANGE [INCH]		JAWS	SHAFT	CAGE SIZE		SPRING				
	MIN	MAX	MIN	MAX			[INCH]	[MM]					
STANDARD	12,40	14,50	0,488	0,571	201MM#36	901MM#151	0,488	12,40	DW-11				
	13,90	16,00	0,547	0,630	203MM#36	905MM#151	0,547	13,90	DW-12,5				
	15,90	18,00	0,626	0,709	205MM#36	909MM#151	0,665	16,90	DW-15,5				
	16,90	19,00	0,665	0,748	207MM#36								
	18,90	21,00	0,744	0,827	209MM#36								
	19,90	22,00	0,783	0,866	211MM#36								
	20,90	23,00	0,823	0,906	213MM#36								
	21,90	24,00	0,862	0,945	214MM#36								
	23,60	25,60	0,929	1,008	215MM#36								
	25,20	27,20	0,992	1,071	217MM#36					915 MM#151	0,787	20,00	0-15
	26,80	28,80	1,055	1,134	219MM#36								
	28,40	30,40	1,118	1,197	221MM#36								0-17
	30,00	32,00	1,181	1,260	223MM#36								
	31,60	33,60	1,244	1,323	225MM#36	0-20							
	33,20	35,20	1,307	1,386	227MM#36								
	34,80	36,80	1,370	1,449	229MM#36								
	36,40	38,40	1,433	1,512	231MM#36	0-22							
	38,00	40,00	1,496	1,575	233MM#36								
	39,60	41,60	1,559	1,638	235MM#36								
	41,20	43,20	1,622	1,701	237MM#36	0-25							
42,80	44,80	1,685	1,764	239MM#36									
44,40	46,40	1,748	1,827	241MM#36									
46,00	48,00	1,811	1,890	243MM#36									

HEAVY DUTY SELF-ALIGNING SHAFT SYSTEMS

The heavy duty series is engineered for high-torque pipe bevelling and applications requiring maximum material removal rates.

SELF-ALIGNING GEOMETRY

The integrated locking system automatically centers the tool within the pipe axis. This eliminates manual adjustment errors and ensures a perfectly square face or uniform bevel angle.

ENHANCED CLAMPING SURFACE

These shafts feature elongated and widened jaws that significantly increase the contact area against the pipe ID. This design maximizes friction and clamping force, preventing tool slippage or vibration during aggressive machining cycles.

STRUCTURAL RIGIDITY

Constructed from hardened engineering-grade alloys, the shaft xx series is designed to withstand the radial and axial forces encountered when working on heavy-wall pipes or hard alloys.

JAWS FOR SHAFT20



SHAFT20 can be used with: MiniMill 101, MiniMill 201, MiniMill 301, PrepMill, HyperMill 56

RANGE [MM]		RANGE [INCH]		JAWS	EXT.	SPRING	
MIN	MAX	MIN	MAX			NO.	QTY.
20,0	24,0	0,787	0,945	NS-0	-	SP-19	1
24,0	28,0	0,945	1,102	NS-1	-	SP-19	1
28,0	33,0	1,102	1,299	NS-2	-	SP-19	1
33,0	38,0	1,299	1,496	NS-3	-	SP-20	2
38,0	43,0	1,496	1,693	NS-4	-	SP-20	2
43,0	48,0	1,693	1,890	NS-5	-	SP-20	2
48,0	53,0	1,890	2,087	NS-6	-	SP-20	2
53,0	58,0	2,087	2,283	NS-7	-	SP-20	2
58,0	63,0	2,283	2,480	NS-8	-	SP-20	2
60,0	65,0	2,362	2,559	NS-5	NS-10	SP-20	2
65,0	70,0	2,559	2,756	NS-6	NS-10	SP-20	2
70,0	75,0	2,756	2,953	NS-7	NS-10	SP-20	2
75,0	80,0	2,953	3,150	NS-8	NS-10	SP-20	2

STANDARD

JAWS FOR SHAFT25



SHAFT25 can be used with: MiniMill 101, PrepMill, HyperMill 56

RANGE [MM]		RANGE [INCH]		JAWS	EXT.	SPRING	
MIN	MAX	MIN	MAX			NO.	QTY.
25,0	30,0	0,984	1,181	NS-1	-	SP-24	1
30,0	35,0	1,181	1,378	NS-2	-	SP-24	1
35,0	40,0	1,378	1,575	NS-3	-	SP-25	2
40,0	45,0	1,575	1,772	NS-4	-	SP-25	2
45,0	50,0	1,772	1,969	NS-5	-	SP-25	2
50,0	55,0	1,969	2,165	NS-6	-	SP-25	2
55,0	60,0	2,165	2,362	NS-7	-	SP-25	2
60,0	65,0	2,362	2,559	NS-8	-	SP-25	2
62,0	67,0	2,441	2,638	NS-5	NS-10	SP-25	2
67,0	72,0	2,638	2,835	NS-6	NS-10	SP-25	2
72,0	77,0	2,835	3,031	NS-7	NS-10	SP-25	2
77,0	82,0	3,031	3,228	NS-8	NS-10	SP-25	2
82,0	87,0	3,228	3,425	NS-5	NS-20	SP-25	2
87,0	92,0	3,425	3,622	NS-6	NS-20	SP-25	2
92,0	97,0	3,622	3,819	NS-7	NS-20	SP-25	2
97,0	102,0	3,819	4,016	NS-8	NS-20	SP-25	2
102,0	107,0	4,016	4,213	NS-5	NS-30	SP-25	2
107,0	112,0	4,213	4,409	NS-6	NS-30	SP-25	2
112,0	117,0	4,409	4,606	NS-7	NS-30	SP-25	2
117,0	122,0	4,606	4,803	NS-8	NS-30	SP-25	2

STANDARD

JAWS FOR SHAFT30



SHAFT30 can be used with: HyperMill 56

RANGE [MM]		RANGE [INCH]		JAWS	EXT.	SPRING	
MIN	MAX	MIN	MAX			NO.	QTY.
30,0	34,0	1,181	1,339	NS-1		SP-29	1
34,0	39,0	1,339	1,535	NS-2		SP-29	1
39,0	44,0	1,535	1,732	NS-3		SP-30	2
44,0	49,0	1,732	1,929	NS-4		SP-30	2
49,0	54,0	1,929	2,126	NS-5		SP-30	2
54,0	59,0	2,126	2,323	NS-6		SP-30	2
59,0	64,0	2,323	2,520	NS-7		SP-30	2
64,0	69,0	2,520	2,717	NS-8		SP-30	2
66,0	71,0	2,598	2,795	NS-5	NS-10	SP-30	2
71,0	76,0	2,795	2,992	NS-6	NS-10	SP-30	2
76,0	81,0	2,992	3,189	NS-7	NS-10	SP-30	2
81,0	86,0	3,189	3,386	NS-8	NS-10	SP-30	2
86,0	91,0	3,386	3,583	NS-5	NS-20	SP-30	2
91,0	96,0	3,583	3,780	NS-6	NS-20	SP-30	2
96,0	101,0	3,780	3,976	NS-7	NS-20	SP-30	2
101,0	106,0	3,976	4,173	NS-8	NS-20	SP-30	2
106,0	111,0	4,173	4,370	NS-5	NS-30	SP-30	2
111,0	116,0	4,370	4,567	NS-6	NS-30	SP-30	2
116,0	121,0	4,567	4,764	NS-7	NS-30	SP-30	2
121,0	126,0	4,764	4,961	NS-8	NS-30	SP-30	2
126,0	131,0	4,961	5,157	NS-5	NS-40	SP-30	2
131,0	136,0	5,157	5,354	NS-6	NS-40	SP-30	2
136,0	141,0	5,354	5,551	NS-7	NS-40	SP-30	2
141,0	146,0	5,551	5,748	NS-8	NS-40	SP-30	2
146,0	151,0	5,748	5,945	NS-5	NS-50	SP-30	2
151,0	156,0	5,945	6,142	NS-6	NS-50	SP-30	2
156,0	161,0	6,142	6,339	NS-7	NS-50	SP-30	2
161,0	166,0	6,339	6,535	NS-8	NS-50	SP-30	2

STANDARD

QuickFacer

MICRO FACING MACHINE

QuickFacer is a compact, high-performance tube facing tool designed for precision weld end preparation and weld removal. This portable micro lathe is suitable for a wide range of tube materials, including stainless steel and high-chromium alloys.

The QuickFacer machine allows for machining tubes from 8,00 up to 38,00 mm OD (0.314"–1.496"), with a locking range of 7,5 to 36,00 mm (0.295"–1.417") and a feed stroke of 15 mm (0.590"). As a standard Quickfacer is equipped with a 50 mm cutting head.

STANDARD SET UP



MICROSHAFT QF

A system with interchangeable guide shafts. Set covers 10,0 to 13,0 mm ID tubes, with option to extend the range.

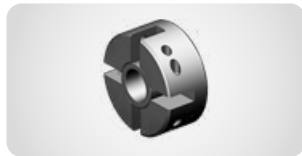

50 MM (2")

The smallest cutter head, designed to fasten the wide range of cutting inserts.



IMPORTANT!
Read how to properly lock on page 85

WORKING RANGE (ID-OD)	LOCKING RANGE (ID)	FEED STROKE	POWER	FREE SPEED	TORQUE
8,00 – 38,0 mm	7,50 – 36,00 mm	15,00 mm	0,7 kW	300 RPM	18 Nm
0,314 – 1,496"	0,307 – 1,417"	0,590"	0,98 Hp	(100 RPM with SpeedReducer)	13,3 Ft.lbs
AIR USE		DIMENSIONS		BODY WEIGHT	
17 cfm	0,48 m ³ /min	1,73 x 10,82 x 12,20"	44 x 275 x 310 mm	7,7 Lbs	3,5 kg

OPTIONAL SHAFT



MINISHAFT QF

Tool set with interchangeable guide shafts. Covers 12,4 to 24,0 mm ID tubes, with option to extend the range.

OPTIONAL HEADS



OBMH

Head designed for outside beveling tubes for wide range of tube sizes.

→ TABLE PAGE 116



STWRMH

Easy to align, sized per tube diameter, head dedicated for strength weld removal.

→ TABLE PAGE 115



TFMH

Tube facing milling head for tubes made of any type of material.

→ TABLE PAGE 115



TFMH127

Tube facing milling head for smallest tubes made of any type of material. Utilizes 6% cobalt special inserts.

BIT	MIN TUBE ID		MAX TUBE OD	
	[INCH]	[MM]	[INCH]	[MM]
CSS 107	0,303	7,70	0,433	11,00
CSS 117	0,327	8,30	0,551	14,00
CSS 127	0,366	9,30	0,591	15,00

QuickFacer

QUICKFACER CLAMPING JAWS SELECTION TABLE

TUBE ID				JAWS	EXPANSION PIN	SHAFT			SPRING
[MM]		[INCH]				SHAFT NR	SHAFT OD		
MIN	MAX	MIN	MAX				[MM]	[INCH]	
7,50	8,00	0,295	0,315	296MM#36	MS#158-40-QF	870QF#151	7,50	0,295	DW-6,5
8,00	8,50	0,315	0,335	297MM#36	MS#158-40-QF	878QF#151	8,00	0,315	DW-7,5
8,50	9,00	0,335	0,354	298MM#36	MS#158-40-QF	878QF#151	8,00	0,315	DW-7,5
9,00	9,50	0,354	0,374	298AMM#36	MS#158-40-QF	878QF#151	8,00	0,315	DW-7,5
9,00	10,00	0,354	0,394	299MM#36	MS#158-51-QF	878QF#151	8,00	0,315	DW-7,5
9,50	10,00	0,374	0,394	298BMM#36	MS#158-40-QF	878QF#151	8,00	0,315	DW-7,5
9,50	10,50	0,374	0,413	300MM#36	MS#158-51-QF	800QF#151	9,00	0,354	DW-7,5
10,00	11,00	0,394	0,433	301MM#36	MS#158-QF	801QF#151	10,00	0,394	DW-7,5
11,00	12,00	0,433	0,472	303MM#36	MS#158-QF	801QF#151	10,00	0,394	DW-8,5
12,00	13,00	0,472	0,512	305MM#36	MS#158-QF	805QF#151	11,50	0,453	DW-10
13,00	14,00	0,512	0,551	307MM#36	MS#158-QF	805QF#151	11,50	0,453	DW-10
14,00	15,00	0,551	0,591	309MM#36	MS#158-QF	805QF#151	11,50	0,453	DW-10
12,40	14,50	0,488	0,571	201MM#36	MM#158-QF	901QF#151	12,40	0,488	DW-11
13,90	16,00	0,547	0,630	203MM#36	MM#158-QF	905QF#151	13,90	0,547	DW-12,5
15,90	18,00	0,626	0,709	205MM#36	MM#158-QF	909QF#151	16,90	0,665	DW-15,5
16,90	19,00	0,665	0,748	207MM#36	MM#158-QF	909QF#151	16,90	0,665	DW-15,5
18,90	21,00	0,744	0,827	209MM#36	MM#158-QF	909QF#151	16,90	0,665	DW-15,5
19,90	22,00	0,783	0,866	211MM#36	MM#158-QF	909QF#151	16,90	0,665	DW-15,5
20,90	23,00	0,823	0,906	213MM#36	MM#158-QF	909QF#151	16,90	0,665	DW-15,5
21,90	24,00	0,862	0,944	214MM#36	MM#158-QF	909QF#151	16,90	0,665	DW-15,5
UP TO 38,00 MM (1,496 INCH)				ON REQUEST	MM#158-QF	915QF#151	20,00	0,787	DW-15,5

OTHER OPTIONAL ACCESSORIES



SPEED REDUCER

Easy to use gearbox for 3x speed reduction. Increases the torque, enabling the machine to generate a thick chip whilst reducing the cutting time.



LEVER FEED

Quick and easy feed system. Used in many basic applications.



FAST CLAMPING SYSTEM

System offers rapid tube to tube cycle time, increased productivity (up to 4x) with little operator fatigue. Ideal for large amount of end preps.

MiniMill 101

The MiniMill 101 is a rugged, fast, portable weld end preparation lathe designed for various tubes and pipes, including stainless steel and other high chromium materials. The machine is offered in two options:

- **MiniMill 101SM**, for general use, can be used for pipe sizes of 20 - 74 mm i.d. (0.787" - 2.913") and comes with an 88 mm cutting head.
- **MiniMill 101SMSS** version is specialized for machining tubes in heat exchanger applications.



IMPORTANT!
Read how to properly lock on page 58

Heavy duty locking system

STANDARD SET UP



SHAFT25
Self-align, heavy duty locking system. Shafts and jaws are longer and wider to ensure maximum clamping force.



88 MM (3,46")
The popular, medium cutter head, designed to fasten the wide range of cutting inserts.

MINIMILL 101SM				MINIMILL 101SMSS			
WORKING RANGE		TOTAL WORKING RANGE		WORKING RANGE		TOTAL WORKING RANGE SS	
APPLICATION	LOCKING	APPLICATION	LOCKING	APPLICATION	LOCKING	APPLICATION	LOCKING
25 - 89 mm	25 - 77 mm	10 - 107 mm	10 - 102 mm	12,4 - 38,0 mm	12,4 - 24,0 mm	10 - 51 mm	10 - 48 mm
0,984 - 3,504"	0,984 - 3,031"	0,394 - 4,213"	0,394 - 4,016"	0,488 - 1,496"	0,488 - 0,945"	0,394 - 2,008"	0,394 - 1,890"
FEED STROKE		POWER		FREE SPEED		TORQUE	
20 mm	0,787"	1,3 hp		100 rpm		140 Nm	105 Ft.lbs
AIR USE		BODY WIDTH		BODY HEIGHT		BODY WEIGHT	
55 cfm	1,3 m ³ /min	2,32"	59 mm	13,1"	335 mm	11,4 Lbs	5,2 kg

STANDARD MINIMILL 101 LOCKING RANGES

SHAFT	JAWS	EXT.	RANGE [MM]		RANGE [INCH]		SPRING		
			MIN	MAX	MIN	MAX	NO.	QTY.	
SHAFT25	NS-1	-	25	30	0,984	1,181	SP-24	1	
	NS-2	-	30	35	1,181	1,378	SP-24	1	
	NS-3	-	35	40	1,378	1,575	SP-25	2	
	NS-4	-	40	45	1,575	1,772	SP-25	2	
	NS-5	-	45	50	1,772	1,969	SP-25	2	
	NS-6	-	50	55	1,969	2,165	SP-25	2	
	NS-7	-	55	60	2,165	2,362	SP-25	2	
	NS-8	-	60	65	2,362	2,559	SP-25	2	
	NS-5	NS-10		62	67	2,441	2,638	SP-25	2
	NS-6	NS-10		67	72	2,638	2,835	SP-25	2
NS-7	NS-10		72	77	2,835	3,031	SP-25	2	

OPTIONAL JAWS

We deliver machines with selected shaft and set of jaws (below). For more locking options please refer to page 86

OPTIONAL SHAFTS



MICROSHAFT
A system with interchangeable guide shafts. A complete set covers 10,0 to 15,0 mm ID tubes.



MINISHAFT
A system with interchangeable guide shafts. A complete set covers 12,4 to 48,0 mm ID tubes.

MiniMill 101

OPTIONAL HEADS



60 MM (2,36")
The smallest cutter head, designed to fasten the wide range of cutting inserts.



106 MM (4,16")
The popular, large cutter head, designed to fasten the wide range of cutting inserts.



OBMH
Head for bevelling tubes without membranes in the boiler water walls.
→ TABLE PAGE 116



SWROTC
Seal weld removal head over tube circumference prior to re-welding the damaged joint without removing the tube.
→ TABLE PAGE 117



STWRMH
Head dedicated for strength weld removal. Heads are easy to align and sized per tube diameter.
→ TABLE PAGE 115



TFMH
Tube facing milling head for tubes made of any type of material. Utilizes 6% cobalt inserts.
→ TABLE PAGE 115

OTHER OPTIONAL ACCESSORIES



RATCHET FEED
Feed system allowing to work in narrow and tight locations, eg. in water walls.



FAST CLAMPING SYSTEM
System offers rapid tube to tube cycle time, increased productivity (up to 4x) with little operator fatigue. Ideal for large amount of end preps.



SPEED REDUCER
Easy to use gearbox for 3x speed reduction. Increases the torque, enabling the machine to generate a thick chip whilst reducing the cutting time.

MINIMILL 101E

MiniMill 101E is electric version of MiniMill 101. A standard machine cover the same pipe sizes and comes with the same cutting head. The electric motor made by Makita with 3 stage planetary gear box made by KRAIS has variable speed control and produce enormous torque. Is interchangeable with pneumatic drive and can be purchased separately at any time.

Model..... ED-230-MM
Free Speed..... 115 RPM
Power..... 750 W
Torque..... 366 NM (280 Ft.Lbs)
Feed Stroke 20 mm (0,787")



AUTOMINIMILL 101P

Auto MiniMill 101P is a fully automatic machine, controlled by a built-in, fully pneumatic control box, with adjustable feed rate and actuated by a hand button (foot switch optional). Ideal for repetitive work cycles on condensers and heat exchangers, as well as for bevelling and facing boiler tubes.

MiniMill 201

The MiniMill 201 is a rugged, fast, portable weld end preparation lathe for various tubes including stainless steel and other high chromium alloys. A standard machine comes complete with a 60 mm head, a locking system and includes all jaw sets to cover sizes of 20 to 44 mm (0.787" to 1.732")

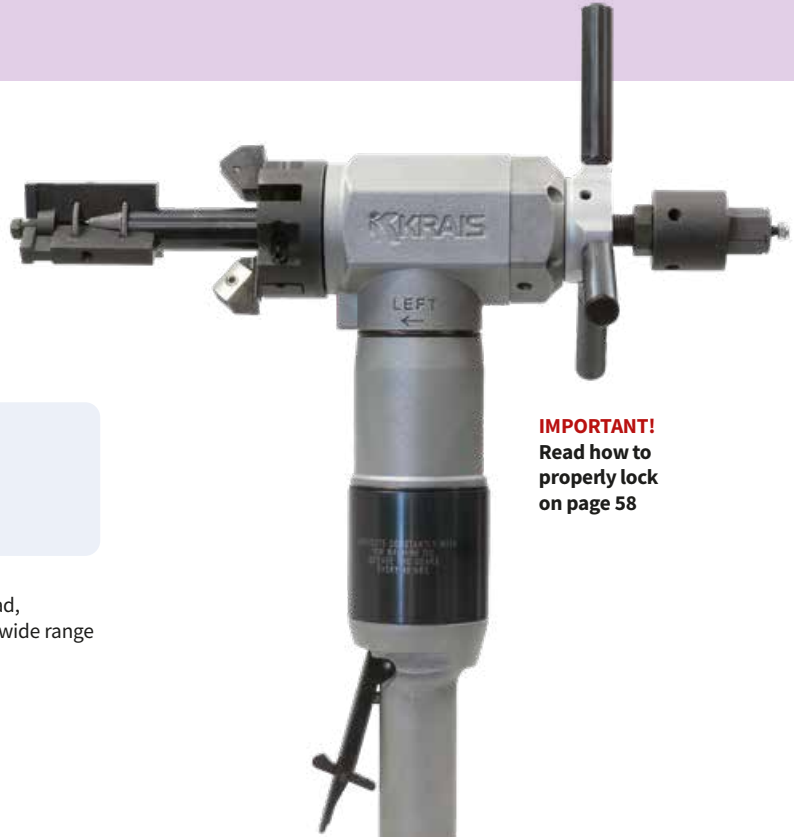

IMPORTANT!
Read how to properly lock on page 58

STANDARD SET UP



SHAFT20

Redesigned heavy duty locking system. Shafts and jaws are longer and wider to ensure maximum clamping force. The jaws are self-align.



60 MM (2,36")

The smallest cutter head, designed to fasten the wide range of cutting inserts.

STANDARD WORKING RANGE				TOTAL WORKING RANGE			
APPLICATION RANGE		LOCKING RANGE		APPLICATION RANGE		LOCKING RANGE	
20 – 51 mm		20 – 48 mm		10 – 51 mm		10 – 48 mm	
0,787 – 2,008"		0,787 – 1,890"		0,394 – 2,008"		0,394 – 1,890"	
FEED STROKE		POWER		FREE SPEED		TORQUE	
20 mm	0,787"	1,3 hp		200 rpm		72 Nm	53 Ft.lbs
55 cfm	1,3 m³/min	2,32"	59 mm	13,1"	335 mm	11,4 Lbs	5,2 kg

STANDARD MINIMILL 201 LOCKING RANGES

SHAFT	JAWS	EXT.	RANGE [MM]		RANGE [INCH]		SPRING	
			MIN	MAX	MIN	MAX	NO.	QTY.
SHAFT20	NS-0	-	20	24	0,787	0,945	SP-19	1
	NS-1	-	24	28	0,945	1,102	SP-19	1
	NS-2	-	28	33	1,102	1,299	SP-19	1
	NS-3	-	33	38	1,299	1,496	SP-20	2
	NS-4	-	38	43	1,496	1,693	SP-20	2
	NS-5	-	43	48	1,693	1,890	SP-20	2

OPTIONAL JAWS

We deliver machines with selected shaft and set of jaws (below). For more locking options please refer to page 86

OPTIONAL SHAFTS



MICROSHAFT

A system with interchangeable guide shafts. A complete set covers 9,0 to 15,0 mm inside diameter.



MINISHAFT

A system with interchangeable guide shafts. A complete set covers 12,4 to 48 mm inside diameter.

MiniMill 201

OPTIONAL HEADS



88 MM (3,46'')
The popular, medium cutter head, designed to fasten the wide range of cutting inserts.



OBMH
Outside beveling of both tubes and pipes. Sized per tube or pipe diameter and angle of required weld bevel.
→ TABLE PAGE 116



SWROTC
Seal weld removal head over tube circumference prior to re-welding the damaged joint without removing the tube.
TABLE PAGE 117



STWRMH
Custom designed head dedicated for strength weld removal. Heads are sized per tube diameter.
→ TABLE PAGE 115

OTHER OPTIONAL ACCESSORIES



RATCHET FEED
Feed system allowing to work in narrow and tight locations, eg. in water walls.



LEVER FEED
Quick and easy feed system. Used in many basic applications.



SPEED REDUCER
Easy to use gearbox for 3x speed reduction. Increases the torque, enabling the machine to generate a thick chip whilst reducing the cutting time.



FAST CLAMPING SYSTEM
System offers rapid tube to tube cycle time, increased productivity (up to 4x) with little operator fatigue. Ideal for large amount of end preps.

EXAMPLE TOOL APPLICATION



Standard locking system with handle feed makes quick work of trimming back tubes.



Completed strength weld removal.



Facing, bevelling tubes quickly and safely.

MiniMill 301LP

The fastest and strongest facing machine on the market. Engineered for safety and ease of use, featuring a pneumatic locking system with a double piston cylinder. Compact milling head with double cutting edge inserts with 6% cobalt. For all types of material including: ferrous, non-ferrous, stainless and exotic alloys steel, duplex, inconel and titanium.



IMPORTANT!
Read how to properly lock on page 58

STANDARD SET UP

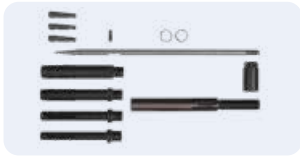

MINISHAFT

A system with interchangeable guide shafts. A complete set covers 12,4 to 48,0 mm ID tubes.



60 MM (2,36")

The smallest cutter head, designed to fasten the wide range of cutting inserts.

STANDARD WORKING RANGE				TOTAL WORKING RANGE			
APPLICATION RANGE		LOCKING RANGE		APPLICATION RANGE		LOCKING RANGE	
12,4 – 38,0 mm		12,4 – 24,0 mm		10 – 51 mm		10 – 48 mm	
0,488 – 1,496"		0,488 – 0,945"		0,394 – 2,008"		0,394 – 1,890"	
FEED STROKE		POWER		FREE SPEED		TORQUE	
20 mm	0,787"	1,3 hp		300 rpm		43 Nm	32 Ft.lbs
55 cfm	1,3 m ³ /min	2,32"	59 mm	13,1"	335 mm	15,4 Lbs	7 kg

STANDARD MINIMILL 301LP LOCKING RANGES

SHAFT	SIZE		JAWS	RANGE [MM]		RANGE [INCH]		SPRING
	[INCH]	[MM]		MIN	MAX	MIN	MAX	
901MM#151	12,40	0,488	201MM#36	12,40	14,50	0,488	0,571	DW-11
905MM#151	13,90	0,547	203 MM#36	13,90	16,00	0,547	0,630	DW-12,5
909MM#151	16,90	0,661	205 MM#36	15,90	18,00	0,626	0,709	DW-15,5
			207 MM#36	16,90	19,00	0,665	0,748	
			209 MM#36	18,90	21,00	0,744	0,827	
			211 MM#36	19,90	22,00	0,783	0,866	
			213 MM#36	20,90	23,00	0,823	0,906	
			214 MM#36	21,90	24,00	0,862	0,945	

OPTIONAL JAWS

We deliver machines with selected shaft and set of jaws (below). For more locking options please refer to page 86

OPTIONAL LOCKING SETS



MICROSHAFT

A system with interchangeable guide shafts. A complete set covers 9,0 to 15,0 mm inside diameter.



SHAFT20

Self-align, heavy duty locking system. Shafts and jaws are longer and wider to ensure maximum clamping force.

MiniMill 301LP

OPTIONAL HEADS



TFMH
Tube facing milling head for tubes made of any type of material. Utilizes 6% cobalt inserts.

→ TABLE PAGE 115



STWRMH
Head for strength weld removal. Easy to align and sized per tube diameter. Must be used with 3X Speed Reducer.

→ TABLE PAGE 115



SPEED REDUCER
Easy to use gearbox for 3x speed reduction. Increases the torque, enabling the machine to generate a thick chip whilst reducing the cutting time.



STAR WHEEL
The most precise feed system. Used in many basic and demanding applications.

EXAMPLE TOOL APPLICATION



The fast locking and the handle feed make this system very efficient for heat exchanger manufacturers.



A real application: shortening a bundle. MiniMill can deal with this task quickly and efficiently.



Double sided inserts and fixed diameter heads ensure unsurpassed efficiency and quality. Mechanical stops ensure identical tube projection.



AUTOMINIMILL 301

Auto MiniMill 301 is a fully automatic machine, controlled by a built-in, fully pneumatic control box, with adjustable feed rate and actuated by a hand button (foot switch optional). Ideal for repetitive work cycles on condensers and heat exchangers, as well as for bevelling and facing boiler tubes.

PrepMill

The PrepMill series pneumatic tube facing, bevelling and weld removal machine. The PrepMill is a rugged, fast, portable weld end preparation lathe for various tubes including stainless steel and other high chromium alloys. Machine is constructed on two opposite set up taper roller bearings that makes the machine extremely stable and very rigid and compact. A standard machine is equipped to cover 25 to 122 mm ID (1" to 4,8") with a 116 mm cutter head.

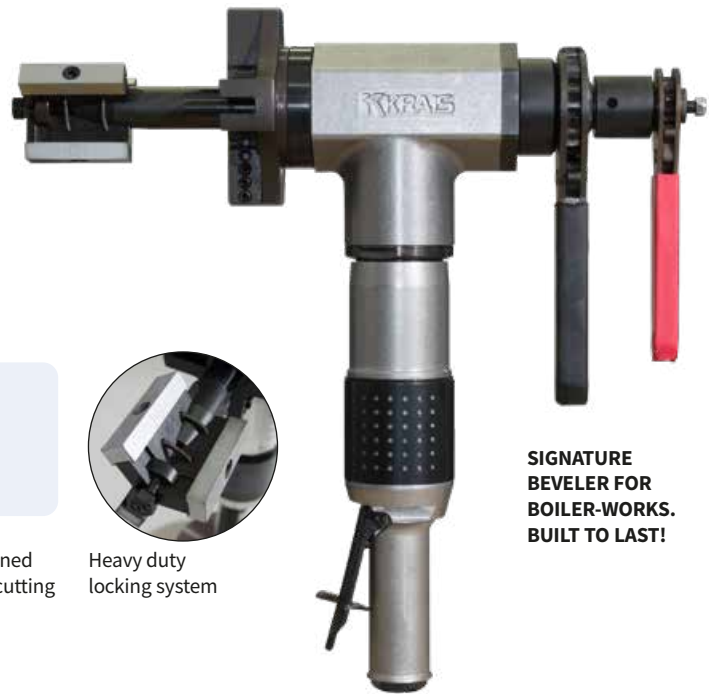

SIGNATURE BEVELER FOR BOILER-WORKS. BUILT TO LAST!

STANDARD SET UP



SHAFT25
Self-align, heavy duty locking system. Shafts and jaws are longer and wider to ensure maximum clamping force.

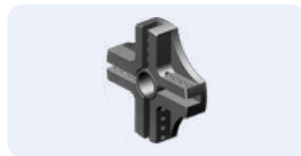

116 MM (4,56")
The large cutter head, designed to fasten the wide range of cutting inserts.



Heavy duty locking system

STANDARD WORKING RANGE		TOTAL WORKING RANGE					
APPLICATION RANGE	LOCKING RANGE	APPLICATION RANGE	LOCKING RANGE				
25 – 127 mm	25 – 122 mm	20 – 127 mm	20 – 122 mm				
1 – 5"	1,0 – 4,8"	0,787 – 5"	0,787 – 4,8"				
FEED STROKE		POWER	FREE SPEED	TORQUE			
25 mm	1"	1,3 hp	120 rpm	140 Nm	105 Ft.lbs		
55 cfm	1,3 m ³ /min	2,59"	66 mm	14,5"	370 mm	20,5 Lbs	9,5 kg

PREPMILL-E

PrepMill-E is electric version of PrepMill. A standard machine can cover the same pipe sizes and comes with the same cutting head. The electric motor made by Makita with 3 stage planetary gear box made by KRAIS has variable speed control and produce enormous torque. Is interchangeable with pneumatic drive and can be purchased separately at any time.

Model..... ED-230-PM
Free Speed..... 115 RPM
Power..... 750 W
Torque..... 368 Nm (280 Ft.Lbs)
Feed Stroke 25 mm (1")



EXAMPLE TOOL APPLICATION



PrepMill with its 66 mm (2-5/8) width body perfectly fit into limited access areas such as Water wall panels. Easy to clamp and feed with our heavy duty ratchet or star wheel feed.

PrepMill

OPTIONAL HEADS



66 MM (2,59")
The smallest cutter head, designed to fasten the wide range of cutting inserts.



88 MM (3,46")
The popular, medium cutter head, designed to fasten the wide range of cutting inserts.



OBPM
Head for outside bevelling of tubes and pipes. Available in wide range of diameters and beveling angles.
→ TABLE PAGE 118



PRRMBH
Head for membrane and overlay removal. Efficiently remove material between boiler tubes.
→ TABLE PAGE 118



STWRPM
Head dedicated for strength weld removal. Heads are easy to align and sized per tube diameter.
→ TABLE PAGE 119



TFPM
Tube facing milling head for tubes made of any type of material. Utilizes 6% cobalt inserts.
→ TABLE PAGE 119

OTHER OPTIONAL ACCESSORIES



HEAD FLANGE
Adapter to use all MiniMill's special cutter heads (from size 1-1/2" and up).



SPEED REDUCER
Easy to use gearbox for 3x speed reduction. Increases the torque, enabling the machine to generate a thick chip whilst reducing the cutting time.



FAST CLAMPING SYSTEM
System offers rapid tube to tube cycle time, increased productivity (up to 4x) with little operator fatigue. Ideal for large amount of end preps.

STANDARD PREPMILL LOCKING RANGES

SHAFT	JAWS	EXT.	RANGE [MM]		RANGE [INCH]		SPRING		
			MIN	MAX	MIN	MAX	NO.	QTY.	
SHAFT25	NS-1	-	25,0	30,0	0,984	1,181	SP-24	1	
	NS-2	-	30,0	35,0	1,181	1,378	SP-24	1	
	NS-3	-	35,0	40,0	1,378	1,575	SP-25	2	
	NS-4	-	40,0	45,0	1,575	1,772	SP-25	2	
	NS-5	-	45,0	50,0	1,772	1,969	SP-25	2	
	NS-6	-	50,0	55,0	1,969	2,165	SP-25	2	
	NS-7	-	55,0	60,0	2,165	2,362	SP-25	2	
	NS-8	-	60,0	65,0	2,362	2,559	SP-25	2	
	NS-5	NS-10		62,0	67,0	2,441	2,638	SP-25	2
	NS-6	NS-10		67,0	72,0	2,638	2,835	SP-25	2
	NS-7	NS-10		72,0	77,0	2,835	3,031	SP-25	2
	NS-8	NS-10		77,0	82,0	3,031	3,228	SP-25	2
	NS-5	NS-20		82,0	87,0	3,228	3,425	SP-25	2
	NS-6	NS-20		87,0	92,0	3,425	3,622	SP-25	2
	NS-7	NS-20		92,0	97,0	3,622	3,819	SP-25	2
	NS-8	NS-20		97,0	102,0	3,819	4,016	SP-25	2
	NS-5	NS-30		102,0	107,0	4,016	4,213	SP-25	2
	NS-6	NS-30		107,0	112,0	4,213	4,409	SP-25	2
NS-7	NS-30		112,0	117,0	4,409	4,606	SP-25	2	
NS-8	NS-30		117,0	122,0	4,606	4,803	SP-25	2	

OPT. SHAFT



STAR WHEEL
The most precise feed system. Used in many basic and demanding applications.



SHAFT20
Self-align, heavy duty locking system. Shafts and jaws are longer and wider to ensure maximum clamping force.

OPTIONAL JAWS

We deliver machines with selected shaft and set of jaws (below). For more locking options please refer to page 86

EXAMPLE TOOL APPLICATION



HyperMill 56

Powerful pneumatic tube facing, bevelling and weld removal machine. The HyperMill 56 is a rugged, fast, portable weld end preparation lathe for various tubes and pipes, including stainless steel and other high chromium materials. A standard machine is equipped with a solid locking system to cover most common tube sizes.



STANDARD SET UP



SHAFT30

Self-align, heavy duty locking system. Shafts and jaws are longer and wider to ensure maximum clamping force.



135 MM (5,3'')

The large cutter head, very sturdy and rigid, designed to fasten the wide range of cutting inserts.



Heavy duty locking system

STANDARD WORKING RANGE				TOTAL WORKING RANGE			
APPLICATION RANGE		LOCKING RANGE		APPLICATION RANGE		LOCKING RANGE	
30 – 136 mm		30 – 136 mm		20 – 175 mm		20 – 166 mm	
1,181 – 5,354"		0,181 – 4,354"		0,787 – 6,890"		0,787 – 6,535"	
FEED STROKE		POWER		FREE SPEED		TORQUE	
40 mm	1,6"	1,3 hp		55 rpm		280 Nm	210 Ft.lbs
55 cfm	1,3 m ³ /min	3,22"	82 mm	15"	385 mm	19 Lbs	9 kg

STANDARD HYPERMILL 56 LOCKING RANGES

SHAFT	JAWS	EXT.	RANGE [MM]		RANGE [INCH]		SPRING		
			MIN	MAX	MIN	MAX	NO.	QTY.	
SHAFT30	NS-1		30,0	34,0	1,181	1,339	SP-29	1	
	NS-2		34,0	39,0	1,339	1,535	SP-29	1	
	NS-3		39,0	44,0	1,535	1,732	SP-30	2	
	NS-4		44,0	49,0	1,732	1,929	SP-30	2	
	NS-5		49,0	54,0	1,929	2,126	SP-30	2	
	NS-6		54,0	59,0	2,126	2,323	SP-30	2	
	NS-7		59,0	64,0	2,323	2,520	SP-30	2	
	NS-8		64,0	69,0	2,520	2,717	SP-30	2	
	NS-5	NS-10		66,0	71,0	2,598	2,795	SP-30	2
	NS-6	NS-10		71,0	76,0	2,795	2,992	SP-30	2
	NS-7	NS-10		76,0	81,0	2,992	3,189	SP-30	2
	NS-8	NS-10		81,0	86,0	3,189	3,386	SP-30	2
	NS-5	NS-20		86,0	91,0	3,386	3,583	SP-30	2
	NS-6	NS-20		91,0	96,0	3,583	3,780	SP-30	2
	NS-7	NS-20		96,0	101,0	3,780	3,976	SP-30	2
	NS-8	NS-20		101,0	106,0	3,976	4,173	SP-30	2
	NS-5	NS-30		106,0	111,0	4,173	4,370	SP-30	2
	NS-6	NS-30		111,0	116,0	4,370	4,567	SP-30	2
	NS-7	NS-30		116,0	121,0	4,567	4,764	SP-30	2
	NS-8	NS-30		121,0	126,0	4,764	4,961	SP-30	2

OPTIONAL JAWS

We deliver machines with selected shaft and set of jaws (below). For more locking options please refer to page 86

OPTIONAL SHAFTS



SHAFT20

Self-align, heavy duty locking system. Shafts and jaws are longer and wider to ensure maximum clamping force.



SHAFT25

Self-align, heavy duty locking system. Shafts and jaws are longer and wider to ensure maximum clamping force.

HyperMill 56

OPTIONAL HEADS



116 MM (4,56")
The large cutter head, designed to fasten the wide range of cutting inserts.



175 MM (6,89")
Cutter head special for the largest machines, designed to fasten the wide range of cutting inserts.



HMRBMH
Head for membrane and overlay removal. Efficiently remove material between boiler tubes.

HYPERMILL LP

The HyperMill LP features a built-in pneumatic locking system with a dual-piston cylinder, enabling fast and secure tube clamping. Designed for high-volume end preps, it increases productivity by up to four times while reducing operator fatigue, making it ideal for efficient, large-scale operations.

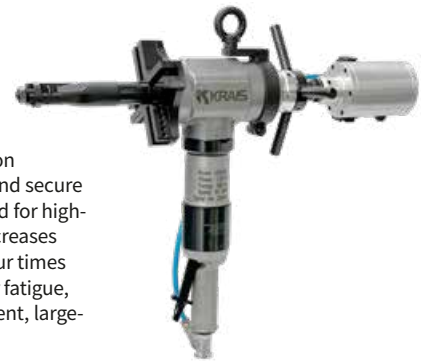

OTHER OPTIONAL ACCESSORIES



HEAD FLANGE
Adapter to use all MiniMill's special cutter heads (from size 1-1/2" and up).



SPEED REDUCER
Easy to use gearbox for 3x speed reduction. Increases the torque, enabling the machine to generate a thick chip whilst reducing the cutting time.



RATCHET FEED
Feed system allowing to work in narrow and tight locations, eg. in water walls.

AVAILABLE HOLDERS

Facing



F-45-90-HM
BIT:
2CDI

Inside beveling and boring



IB-45-37-HM
IB-45-10-HM
BIT:
2CDI

Outside beveling



OB-45-45-HM
OB-45-37-HM
OB-45-30-HM
OB-45-10-HM
BIT:
2CDI

HYPERMILL 56E

HyperMill 56E is electric version of HyperMill 56. The machine can cover the same pipe sizes and comes with the same cutting head. The electric motor made by Makita with 3 stage planetary gear box made by KRAIS has variable speed control and produce enormous torque. Is interchangeable with pneumatic drive and can be purchased separately at any time.

Model ED-230-HM
Free Speed..... 58 RPM
Power..... 750 W
Torque..... 720 Nm (530 Ft.Lbs)
Feed Stroke 40 mm (1,6")



BATTERY OPTION

The machine is also available with a portable electric drive 18 Volt 5.2 Ah 93.6 Wh Li-Lon battery. The machine can operate up to half hour on one battery. It is possible to have many charged batteries. Comfortable and easy to use in any place where compressed air and electricity is not available or even impossible to use as for example oil refinery.



PipeMill-8

PipeMill-8 is a high-performance pneumatic tube facing, beveling, and weld removal machine engineered for demanding industrial applications. Designed for speed, durability, and precision, PipeMill-8 delivers reliable weld end preparation on a wide range of pipe materials, including stainless steel and other exotic alloys.

Its robust construction and powerful pneumatic drive ensure consistent cutting performance, while the internal locking system provides fast and secure setup on pipes with inside diameters from 50.8 to 172 mm (2.000" to 6.800"). Equipped with a 250 mm cutting head, PipeMill-8 offers excellent machining accuracy, making it an ideal solution for workshop and on-site operations where efficiency and quality are critical.

STANDARD SET UP



250 MM (9,8")

Cutter head special for the largest machines. Very rigid. Designed to fasten the wide range of cutting inserts.



STANDARD WORKING RANGE				OPTIONAL WORKING RANGE			
APPLICATION RANGE		LOCKING RANGE		APPLICATION RANGE		LOCKING RANGE	
50 – 279 mm		50 – 319 mm		50 – 319 mm		50 – 319 mm	
1,968 – 10,984"		1,968 – 12,559"		1,968 – 12,559"		1,968 – 12,559"	
FEED STROKE		POWER		FREE SPEED		TORQUE	
50 mm	1,968"	1,3 hp		Depends on gear			
AIR USE		BODY WIDTH		BODY HEIGHT		BODY WEIGHT	
70 cfm	2,2 m ³ /min	5,7"	145 mm	21,5"	550 mm	52,9 Lbs	24 kg

LOCKING RANGES WITH STANDARD JAWS

JAWS: SM-42

RANGE [MM]		RANGE [INCH]		EXTENSIONS		
MIN	MAX	MIN	MAX	A	B	C
50,0	65,0	1,969	2,559			
65,0	80,0	2,559	3,150	ML-42-A-75		
80,0	95,0	3,150	3,740	ML-42-A-150		
95,0	110,0	3,740	4,331	ML-42-A-225		
110,0	125,0	4,331	4,921	ML-42-A-300		
125,0	140,0	4,921	5,512	ML-42-A-375		
140,0	155,0	5,512	6,102			SML-42-C
155,0	170,0	6,102	6,693	ML-42-A-75		SML-42-C
170,0	184,5	6,693	7,264	ML-42-A-150		SML-42-C
184,5	199,0	7,264	7,835	ML-42-A-225		SML-42-C
199,0	214,0	7,835	8,425	ML-42-A-300		SML-42-C
214,0	229,0	8,425	9,016	ML-42-A-375		SML-42-C
229,0	244,5	9,016	9,626		ML-42-B	SML-42-C
244,5	259,5	9,626	10,217	ML-42-A-75	ML-42-B	SML-42-C
259,5	274,0	10,217	10,787	ML-42-A-150	ML-42-B	SML-42-C
274,0	289,0	10,787	11,378	ML-42-A-225	ML-42-B	SML-42-C
289,0	304,0	11,378	11,969	ML-42-A-300	ML-42-B	SML-42-C
304,0	319,0	11,969	12,559	ML-42-A-375	ML-42-B	SML-42-C

AVAILABLE GEARBOX CONFIGURATIONS

This tool comes with one chosen gearbox as a standard. Torque/speed depends on gear configuration:





GEARBOX 15	15 RPM	2544 Nm	1908 Ft.Lbs
GEARBOX 20	20 RPM	1883 Nm	1415 Ft.Lbs
GEARBOX 28	28 RPM	1290 Nm	969 Ft.Lbs
GEARBOX 37	37 RPM	971 Nm	730 Ft.Lbs

EXAMPLE TOOL APPLICATION



PipeMill-8

AVAILABLE HOLDERS

Facing	Inside bevelling and boring	Outside bevelling	J-Prep	Compound bevelling
				
F-45-90 BIT: 2CDI	IB-45-37 IB-45-10 BIT: 2CDI	OB-45-45 OB-45-37 OB-45-30 OB-45-10 BIT: 2CDI	JP-45-45 JP-45-37 JP-45-30 BIT: 2CDJ-5	CB-1037 (OTHERS ON REQUEST) BIT: CB-45

PIPEMILL-8-H – HYDRAULIC VERSION

PipeMill-8-H is the hydraulic version of the PipeMill machine, covering the same pipe size range and using the same cutting head as other PipeMill-8 versions. The hydraulic motor provides high, constant torque for efficient and precise cutting, with performance dependent on oil pressure and flow from an external power unit. PipeMill-8-H is interchangeable with electric and pneumatic drives, allowing conversion in approximately 5 minutes. Its robust yet lightweight design makes it suitable for both field and industrial applications.



- Motor constant free speed 375 RPM
- Oil pressure required..... 160 bar
- Oil flow max 75 l/min
- Motor power..... 16,2 Hp
- Machine feed stroke 40 mm (1,6")
- Cutter head max free speed..... 75 RPM
- Max constant torque on cutter blade..... 2200 Nm (1625 Ft.Lbs)
- Total machine weight..... 41 kg

OPTIONAL HEAD



290 MM (11,4")
Biggest head for Mini & HyperMill tools.
Very rigid. Designed to fasten the wide range of cutting inserts.

PIPEMILL-8-E – ELECTRIC VERSION

PipeMill-8-E is electric version of PipeMill-8. The machine can cover the same pipe sizes and comes with the same cutting head. The electric motor with 4 speed mechanical gear box has also variable speed control and produce enormous torque on the cutter blade. Is interchangeable with pneumatic drive and can be purchased separately at any time. Take 5 min to replace from pneumatic to electric.

- DUDE-2000-4-SPEED
- Motor free speed..... 120-210-380-650 RPM
- Motor power..... 2000 W
- Motor torque (on the 1st gear)..... 240 Nm (180 Ft.Lbs)
- Machine feed stroke 40 mm (1,6")
- Cutter head speed 10-17-30-50 rpm
- Max torque on cutter blade (on the 1st gear) 3096 Nm (2290 Ft.Lbs)

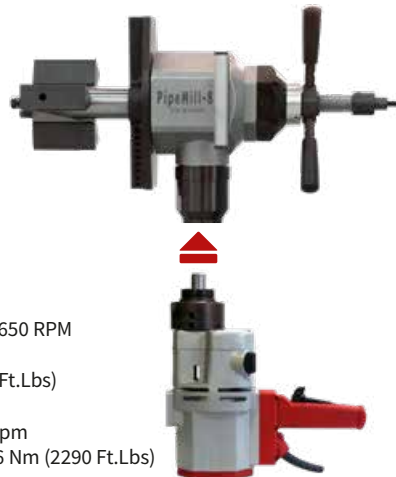

SmartMill-8

Most powerful machine within this size range on the market today. Utilizes a powerful 2.2 kW (3 HP) pneumatic motor that is entirely engineered and manufactured by KRAIS. SmartMill-8 has a unique construction that has been specifically designed for the largest end prep systems.

- ▶ Self-centering 40 mm (1,57") one piece locking shaft.
- ▶ Only one mandrel and 6 Jaw sets needed to cover machines entire range.
- ▶ Wide clamps produce superior clamping force for chatter free end preps.
- ▶ Fully portable for on-site and Fab-shop work.

SmartMill-8 is available for sale or rent.



STANDARD WORKING RANGE		FEED STROKE	FREE SPEED	POWER	TORQUE		
APPLICATION RANGE	LOCKING RANGE						
40 - 219 mm	40 - 203,5 mm	50 mm	39 Rpm	3,0 hp	930 Nm		
1,574 - 8,622"	1,574 - 8,012"	2"			697 Ft.Lbs		
AIR USE		AIR PRESSURE		BODY DIMENSIONS		BODY WEIGHT	
75 cfm	2,2 m ³ /min	90 PSI	6,2 Bar	22 x 9,25 x 7,48"	560 x 235 x 190 mm	46 Lbs	21 kg

ADVANTAGES OF SMARTMILL-8



UNIQUE SHAFT DESIGN
40 mm (1,57") shaft, assures rigidity when machining heavy wall pipe. Only 6 set of jaws needed to cover the full locking range.



POWERFUL MOTOR UNIT
SmartMill-8 is powered by powerful and efficient drives dedicated for our Lathe series beveling machines.



LIGHTWEIGHT AND PORTABLE
The innovative design made it possible to produce lightweight and portable machine. Small weight of SmartMill-8 allows for fatigue-free operation in all conditions.



HEAVY DUTY HANDLE
Machine is equipped with a solid and convenient aluminium handle.

OPTIONAL SHAFT



30 MM SHAFT
Optional shaft to enable the machine to be used for smaller tubes. The shaft is supplied with complete jaws set to cover up to 2" ID.





OPTIONAL RIGHTANGLE CONFIGURATION



The SmartMill 8 drive can be easily converted into right angle version. It can be achieved thanks to special Rightangle Head, mounted in few minutes between regular drive and machine. The option can be helpful where is not enough space for the in-line version.

SmartMill-8

AVAILABLE HOLDERS

Facing	Inside bevelling and boring	Outside bevelling	J-Prep	Compound bevelling
				
F-45-90 BIT: 2CDI	IB-45-37 IB-45-10 BIT: 2CDI	OB-45-45 OB-45-37 OB-45-30 OB-45-10 BIT: 2CDI	JP-45-45 JP-45-37 JP-45-30 BIT: 2CDJ-5	CB-1037 (OTHERS ON REQUEST) BIT: CB-45

OPTIONAL SERVO DRIVE



EV-2000 SYNC

The machine can be driven by modern, high-tech KRAIS AC servo motor for controlled axis motion. They ensure highly accurate and smooth machine motion. The motor has a rated output of 3 kW, rated speed of 2000 r/min, and rated torque of 14.3 Nm.

OPTIONAL ELECTRIC MOTOR UNIT



SmartMill-8E is electric version of SmartMill-8. The machine can cover the same pipe sizes and comes with the same cutting head. The electric motor with 4 speed mechanical gear box has also variable speed control and produce enormous torque on the cutter blade. Is interchangeable with pneumatic drive and can be purchased separately at any time. Take 5 min to replace from pneumatic to electric.

DUDE-2000-4-SPEED

Motor free speed: 120-210-380-650 RPM
 Motor power: 2000 Watt
 Motor torque (on the 1st gear): 240 Nm (180 Ft.Lbs)
 Machine feed stroke: 50 mm (2")
 Cutter head speed: 8-14-25-43 rpm
 Max torque on cutter blade (on the 1st gear): 3600 Nm (2664 Ft.Lbs)

LOCKING WITH STANDARD JAWS

RANGE [MM]		RANGE [INCH]		SEGMENTS	
MIN	MAX	MIN	MAX	FIRST	NEXT
40,0	55,0	1,575	2,165	SM-42-0	none
55,0	69,5	2,165	2,736	SM-42-1	none
69,5	84,0	2,736	3,307	SM-42-1	ML-42-A-75
84,0	98,5	3,307	3,878		ML-42-A-150
98,5	113,5	3,878	4,469		ML-42-A-225
113,5	128,5	4,469	5,059		ML-42-A-300
128,5	143,5	5,059	5,650		ML-42-A-300
					ML-42-A-75
143,5	158,5	5,650	6,240		ML-42-A-300
					ML-42-A-150
158,5	173,5	6,240	6,831		ML-42-A-300
					ML-42-A-225
173,5	188,5	6,831	7,421	ML-42-A-300	
				ML-42-A-225	
188,5	203,5	7,421	8,012	ML-42-A-300	
				ML-42-A-225	
				ML-42-A-150	

SMARTMILL-8 PERFORMANCE



The SmartMill-8 is the most powerful machine in its class currently available on the market.



SMARTMILL-8H – HYDRAULIC VERSION

SmartMill-8H is the hydraulic version of the machine, sharing the same pipe range and cutting head as other 8-series models. Its hydraulic motor delivers high, constant torque for precision cutting, powered by an external unit. The drive is interchangeable with electric or pneumatic versions in just 5 minutes. Its robust yet lightweight design makes it ideal for both field and industrial use.

Motor constant free speed 375 RPM
 Oil pressure required 160 bar
 Oil flow max 75 l/min
 Motor power 16,2 Hp
 Machine feed stroke 40 mm (1,6")
 Cutter head max free speed 75 RPM
 Max constant torque on cutter blade 2200 Nm (1625 Ft.Lbs)
 Total machine weight 41 kg

PanelMill 65

The PanelMill attaches to the tube outside diameter by means of custom or specific clamp type jaws that provide strong clamping action that minimizes chatter and vibration.

Rugged construction allows the tool's cutting blade to end prep quickly. Several cutter heads are available for tubes with up to 2-1/2" O.D. Both the clamp and cutter heads are extremely durable and easy to change.

The ratchet feed arm enables the operator to comfortably feed the tool during bevelling or facing. The PanelMill is suitable for small bore heavy wall tubes with a high percentage of chrome, stainless steel, and other exotic alloys. Standard and custom made blades are offered in a wide variety of angles and sizes.

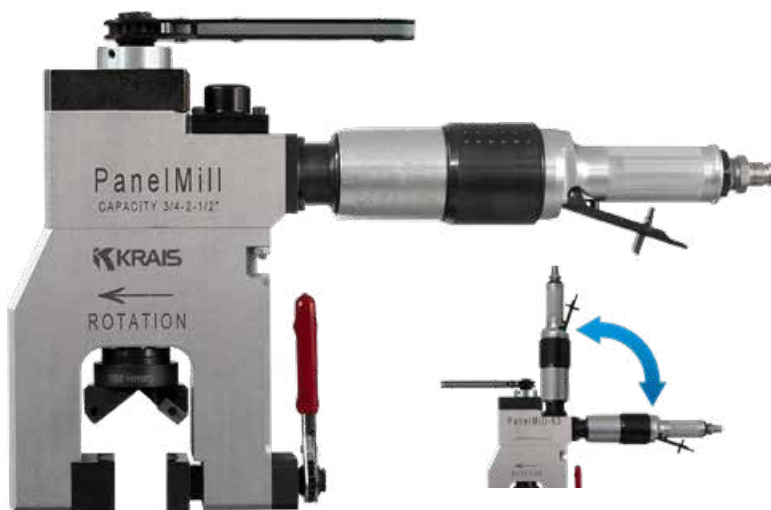

	WORKING RANGE [MM]		WORKING RANGE [INCH]		CLEARANCE		CLADDING REMOVAL		MEMBRANE UP TO		FEED STROKE		FREE SPEED	TORQUE	
	MIN	MAX	MIN	MAX	[MM]	[INCH]	[MM]	[INCH]	[MM]	[INCH]	[MM]	[INCH]	[RPM]	[NM]	[FT.LBS]
65EXT	19,0	63,5	0,75"	2,50"	70,0	2,75"	44,4	1,75"	51,0	2,0"	25,5	1"	100*	140	105
65EXT-M*	19,0	63,5	0,75"	2,50"	84,0	3,3"	63,5	2,50"	63,5	2,5"	25,4	1"	100*	140	105
101	50,0	101,0	2"	4"	122,0	4,8"	88,9	3,50"	122,0	4,8"	25,4	1"	100**	140	105

*65EXT-M working range +63,5 mm membrane; **65EXT and EXT-M optional free speeds are 35, 200 and 300 RPM; ***101 optional free speed: 40 RPM

	AIR USE		BODY WIDTH		BODY HEIGHT		WEIGHT	
	[CFM]	[M ³ /MIN]	[MM]	[INCH]	[MM]	[INCH]	[KG]	[LBS]
65EXT	55	1,3	50	1,96"	300	11,81"	10	22
65EXT-M	55	1,3	50	1,96"	320	12,60"	11	24
101	55	1,3	50	1,96"	350	13,78"	18	40

STANDARD JAWS

JAWS NO.	TUBE OD	
	[MM]	[INCH]
308 PM#2	25,40	1,000
314 PM#2	31,70	1,248
322 PM#2	38,10	1,500
330 PM#2	50,80	2,000
334 PM#2	57,10	2,248

OPTIONAL JAWS

JAWS NO.	TUBE OD	
	[MM]	[INCH]
300 PM#2	19,05	0,750
301 PM#2	20,00	0,787
304 PM#2	22,20	0,874
309 PM#2	25,00	0,984
312 PM#2	28,80	1,134
313 PM#2	30,00	1,181
318 PM#2	34,90	1,374
326 PM#2	44,40	1,748
331 PM#2	51,00	2,008
338 PM#2	60,30	2,374

PANELMILL-E

PanelMill E is electric version of PanelMill. A standard machine cover the same pipe sizes and comes with the same cutting head. The electric motor made by Makita with 3 stage planetary gear box made by KRAIS has variable speed control and produce enormous torque. Is interchangeable with pneumatic drive and can be purchased separately at any time.

Model ED-230-PME
 Free Speed.....115 RPM
 Power.....750 W
 Torque.....366 NM (280 Ft.Lbs)
 Feed Stroke20 mm (0,787")



PanelMill 65

UNIVERSAL CUTTER HEADS



50 MM (1,97'')
Head supplied with PanelMill 63. Designed to fasten wide range of cutting inserts.



63 MM (2,48'')
Head supplied with PanelMill 100. Designed to fasten wide range of cutting inserts.



BIT & HOLDERS
Universal cutter heads can hold a wide range of holders, with a bunch types of bits.

→ TABLE PAGE 44

MACHINING IN EVERY POSITION



OUTSIDE BEVELLING HEAD



BIT: HSS 6% COBALT
DEGREE: 37,5°

Outside beveling head for machining tubes without membranes in a boiler water wall.

HEAD NR	TUBE CAPACITY			RANGE [INCH]		RANGE [MM]		INSERT	NO. OF INSERTS
	[INCH]	[MM]	BWG	MIN	MAX	MIN	MAX		
OBPMH-254	1,000	25,40	11-23	0,315	1,339	8,00	34,00	WRIL	2
OBPMH-285	1,125	28,58	11-23	0,307	1,331	7,80	33,80	WRIL	2
OBPMH-317	1,250	31,75	8-23	0,433	1,457	11,00	37,00	WRIL	2
OBPMH-381	1,500	38,10	6-23	0,681	1,705	17,30	43,30	WRIL	2
OBPMH-444	1,750	44,45	6-23	0,929	1,953	23,60	49,60	WRIL	2
OBPMH-508	2,000	50,80	6-23	1,181	2,205	30,00	56,00	WRIL	2
OBPMH-571	2,250	57,15	6-23	1,433	2,457	36,40	62,40	WRIL	2
OBPMH-603	2,375	60,33	6-23	1,535	2,559	39,00	65,00	WRIL	2
OBPMH-635	2,500	63,50	6-23	1,654	2,677	42,00	68,00	WRIL	2

MEMBRANE REMOVAL HEAD



BIT: CARBIDE

Specially designed head for membrane removal and overlay head (cladding removal)

HEAD NR	TUBE CAPACITY		RANGE [INCH]		RANGE [MM]		INSERT	NO. OF INSERTS
	[INCH]	[MM]	MIN	MAX	MIN	MAX		
PMRBMH-254	1,000	25,40	1,000	1,630	25,40	41,40	PO8	4
PMRBMH-288	1,125	28,58	1,134	1,764	28,80	44,80	PO8	5
PMRBMH-317	1,250	31,75	1,248	1,878	31,70	47,70	PO8	5
PMRBMH-381	1,500	38,10	1,500	2,130	38,10	54,10	PO8	6
PMRBMH-444	1,750	44,45	1,748	2,378	44,40	60,40	PO8	6
PMRBMH-508	2,000	50,80	2,000	2,630	50,80	66,80	PO8	7
PMRBMH-571	2,250	57,15	2,252	2,882	57,20	73,20	PO8	7
PMRBMH-603	2,375	60,33	2,374	3,004	60,30	76,30	PO8	7
PMRBMH-635	2,500	63,50	2,500	3,130	63,50	79,50	PO8	7
PMRBMH-762	3,000	76,20	3,000	3,630	76,20	92,20	PO8	8
PMRBMH-889	3,500	88,90	3,500	4,130	88,90	104,90	PO8	8
PMRBMH-101	4,000	101,60	4,000	4,630	101,60	117,60	PO8	9

PanelDrill

The KRAIS PanelDrill is a modular machine for the boiler waterwalls manufactures.

This is the first outside mounting tool with unique up to 80 mm feed stroke and 50 mm thick drive spindle.

Thanks to long feed stroke, rigid construction, powerful drives options and strong clamping PanelDrill is much more comfortable than other solutions. Minimized chatter and vibration results in smooth machining and operator convenience. The PanelDrill is suitable for small bore, heavy wall tubes with a high percentage of chrome, stainless steel and other exotic alloys.

The machine is offered with a choice of one from 3 available clamping jaws: 2,5", 3" or 4" OD, other sizes are just on request.



The crank arm enables the operator to smooth and fast feeding the tool during beveling or facing.

AVAILABLE CLAMPS



2,5" CLAMPS

Basic clamps allows for machining tubes with MiniDrill up to 2,5" with 2" feed range.



3" CLAMP

The mid 3" clamps increases MiniDrill capacity up to 76 mm (3") with 2" feed range.



4" CLAMP

The biggest, 4" clamps increases MiniDrill capacity up to 101 mm (4") with 2" feed range.

	WORKING RANGE [MM]		WORKING RANGE [INCH]		CLEARANCE		CLADDING REMOVAL		MEMBRANE UP TO		FEED STROKE		FREE SPEED	TORQUE	
	MIN	MAX	MIN	MAX	[MM]	[INCH]	[MM]	[INCH]	[MM]	[INCH]	[MM]	[INCH]	[RPM]	[NM]	[FT.LBS]
PanelDrill 2,5" clamps	19,0	63,5	0,75"	2,50"	70,0	2,75"	44,4	1,75"	51,0	2,0"	50	2"	100*	140	105
PanelDrill 3,0" clamps	19,0	76,0	0,75"	3,00"	84,0	3,3"	63,5	2,50"	63,5	2,5"	50	2"	100*	140	105
PanelDrill 4,0" clamps	50,0	101,0	2,00"	4,00"	122,0	4,8"	88,9	3,50"	122,0	4,8"	50	2"	100**	140	105

*PanelDrill with 2,5" and 3" clamps optional free speeds are 35, 200 and 300 RPM; **PanelDrill with 4" clamps optional free speed: 35 RPM with Speedreducer

	AIR USE		BODY WIDTH		BODY HEIGHT		WEIGHT	
	[CFM]	[M ³ /MIN]	[MM]	[INCH]	[MM]	[INCH]	[KG]	[LBS]
PanelDrill 2,5" clamps	55	1,3	50	1,96"	300	11,81"	10	22
PanelDrill 3,0" clamps	55	1,3	50	1,96"	320	12,60"	11	24
PanelDrill 4,0" clamps	55	1,3	50	1,96"	350	13,78"	18	40

PanelDrill

UNIVERSAL CUTTER HEADS AND HOLDERS



50 MM
Standard cutter head, delivered with 2,5" clamps, covers full range from 19 to 63,5 mm tubes.



63 MM (2,48")
Head supplied with 3" clamps. Designed to fasten wide range of cutting inserts.



101 MM (3,97")
Head supplied with biggest 4" clamps. Designed to fasten wide range of cutting inserts.



BIT & HOLDERS
Wide range of holders, with a standard and custom made blades are offered in a wide variety of angles and sizes.

OPTIONAL LONG FEED SYSTEM



Special version of clamps and spindle with longer feed stroke. Depending on the application, there is a possibility to build machine with stroke even up to 80 mm. Please consult with factory if you have an application that needs even longer feed.

All cutter heads are based on Weldon type gripper.

→ TABLE PAGE 44

OTHER



SPEED REDUCER
Easy to use gearbox for 3x speed reduction. Increases the torque, enabling the machine to generate a thick chip whilst reducing the cutting time.

PANELDRILL PERFORMANCE



PanelDrill during 2" carbon steel membrane removal.

PANELDRILL-E

PanelDrill E is electric version of PanelDrill. A standard machine cover the same pipe sizes and comes with the same cutting head. The electric motor made by Makita with 3 stage planetary gear box made by KRAIS has variable speed control and produce enormous torque. Is interchangeable with pneumatic drive and can be purchased separately at any time.

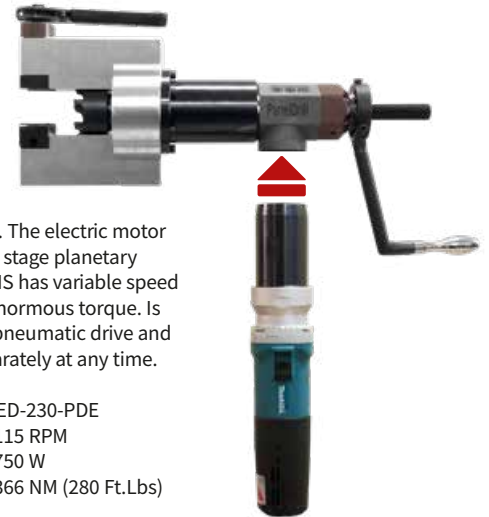

Model ED-230-PDE
Free Speed.....115 RPM
Power.....750 W
Torque.....366 NM (280 Ft.Lbs)

CLAMPING JAWS FOR PANELDRILL

JAWS	TUBE OD	
	[MM]	[INCH]
300 PM#2	19,05	0,750
301 PM#2	20,00	0,787
304 PM#2	22,20	0,874
308 PM#2	25,40	1,000
309 PM#2	25,00	0,984
312 PM#2	28,80	1,134
313 PM#2	30,00	1,181
314 PM#2	31,70	1,248
318 PM#2	34,90	1,374
322 PM#2	38,10	1,500
326 PM#2	44,40	1,748
330 PM#2	50,80	2,000
331 PM#2	51,00	2,008
334 PM#2	57,10	2,248
338 PM#2	60,30	2,374
342 PM#2	63,50	2,500
346 PM#2	76,20	3,000
350 PM#2	88,90	3,500
400 PM#2	101,60	4,000

PanelMill PF

KRAIS PanelMill PF is the first machine where the bevelling cycle time is not dependent on an operator efficiency but on the machine mechanism. Both, the feed mechanism and the spindle rotation mechanism are driven from one source. A fixed rate of spindle advancement is achieved for each rotation of the spindle so every stroke cycle is predictable.

The standard machine has 35 mm feed stroke (longer ones are available as option).

PanelMill PF – positive feed bevelling machine, is highly recommended for tube end facing, bevelling, and membrane milling in water wall panels. As well as for the tube end preparation in the boiler and heat exchanger industry and FAB shops.

STANDARD SET UP



CUTTER HEAD 66 MM

Cutter head thanks to special way of fixing with spindle can cover full range from 0 to 76 mm

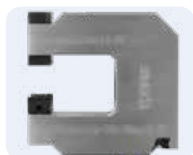

3" CLAMPS

Standard machine clamps allows for machining tubes up to 3" with 35 mm positive feed range.



35 MM SPINDLE

Heavy duty 35 mm (1-3/8") diameter spindle. The best stability and rigidity available on the market within this machine sizes!



The first one in the world! OD clamp pipe bevelling machine with Positive Feed.

STANDARD WORKING RANGE			OPTIONAL WORKING RANGE		
APPLICATION	FEED STROKE	FEED PER REV.	APPLICATION	FEED STROKE	FEED PER REV.
19,05 - 76,20 mm	35 mm	0,1 mm	51 - 114 mm	35 mm	0,1 mm
0,75 - 3,00"	1,377"	0,003"	2,00 - 4,50"	1,377"	0,003"
POWER	FREE SPEED	TORQUE	POWER	FREE SPEED	TORQUE
2,2 hp	125 Rpm	300 Nm	2,2 Hp	100 Rpm	360 Nm

STANDARD JAWS

JAWS NO.	TUBE OD	
	[MM]	[INCH]
308 PM#2	25,40	1,000
314 PM#2	31,70	1,248
322 PM#2	38,10	1,500
330 PM#2	50,80	2,000
342 PM#2	63,50	2,500
346 PM#2	76,20	3,000

OPTIONAL JAWS

JAWS NO.	TUBE OD	
	[MM]	[INCH]
300 PM#2	19,05	0,750
301 PM#2	20,00	0,787
304 PM#2	22,20	0,874
309 PM#2	25,00	0,984
312 PM#2	28,80	1,134
313 PM#2	30,00	1,181
318 PM#2	34,90	1,374
326 PM#2	44,40	1,748
331 PM#2	51,00	2,008
334 PM#2	57,10	2,248
338 PM#2	60,30	2,374

TWO VARIANTS



PanelMill-PF is available in two versions: right angle and in-line. You can choose the version, which suits better for your needs. Both models have exactly the same parameters.

PanelMill PF

UNIVERSAL CUTTER HEADS



PMH-PF-66
66 MM (2,598")
 Head supplied with PanelMill 3". Designed to fasten wide range of cutting inserts.



PMH-PF-99
99 MM (3,897")
 Head supplied with PanelMill 4,5". Designed to fasten wide range of cutting inserts.



BIT & HOLDERS
 Universal cutter heads can hold a wide range of holders, with a bunch types of bits.

OUTSIDE BEVELLING HEAD



Angle: 37,5°; for tubes without membranes, with HSS 6% cobalt bits.

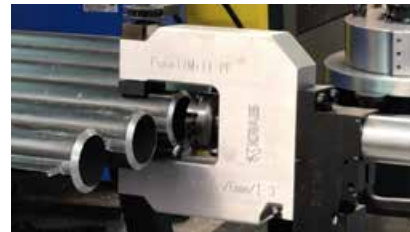

HEAD NR	TUBE CAPACITY			RANGE [INCH]		RANGE [MM]		INSERT	NO. OF INS.
	[INCH]	[MM]	BWG	MIN	MAX	MIN	MAX		
OBPMH-PF-285	1,125	28,58	11-23	0,890	1,240	22,60	31,50	WRIL	2
OBPMH-PF-317	1,250	31,75	8-23	0,917	1,732	23,30	44,00	WRIL	2
OBPMH-PF-381	1,500	38,10	6-23	0,984	1,850	25,00	47,00	WRIL	2
OBPMH-PF-444	1,750	44,45	6-23	1,024	1,890	26,00	48,00	WRIL	2
OBPMH-PF-508	2,000	50,80	6-23	1,181	2,047	30,00	52,00	WRIL	2
OBPMH-PF-571	2,250	57,15	6-23	1,417	2,283	36,00	58,00	WRIL	2
OBPMH-PF-603	2,375	60,33	6-23	1,535	2,402	39,00	61,00	WRIL	2
OBPMH-PF-635	2,500	63,50	6-23	1,654	2,559	42,00	65,00	WRIL	2
OBPMH-PF-889	3,500	88,90	6-23	2,677	3,543	68,00	90,00	WRIL	2

OPTIONAL PARTS

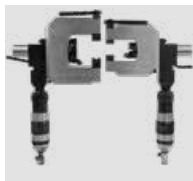

4,5" CLAMP
 The bigger 4,5" clamp to increase PanelMill PF capacity up to 114 mm (4,5"). With this clamp the machine covers tube range from 51 to 114 mm (2-4,5").



LONG FEED STROKE
 Special version of clamps and sindle with longer feed stroke. Depending on the application, there is a possibility to build machine with stroke even up to 4". Please consult with factory if you have an application that needs even longer feed.



BENCH MOUNT PLATE (BMP)
 Thanks to bench mount plate, it is possible to attach PanelMill to the table/worktop. A table base allows you to convert PanelMill-PF to a table machine for bevelling pipes, stubs or elbows. This is only available for 4,5" clamp only.

CLADDING REMOVAL HEAD



Head with carbide bits.



HEAD NR	TUBE CAPACITY		INSERT	NO. OF INSERTS
	[INCH]	[MM]		
CRH-PF-508	2,000	50,80	CI 9x9	3
CRH-PF-571	2,250	57,15	CI 9x9	3
CRH-PF-603	2,375	60,33	CI 9x9	3
CRH-PF-635	2,500	63,50	CI 9x9	3
CRH-PF-762	3,000	76,20	CI 9x9	3

PANELMILL PF-E

PanelMill PF can be driven by electric motor. Thus equipped machine covers the same working range but gets much more mobility. We offer two drives with different free speed. Both of them are run by Makita motor and use planetary gear Box's made by KRAIS. It has variable speed control and produce enormous torque. Electric drives are interchangeable with pneumatic one and can be purchased separately at any time.



PanelMill Size	3"	4,5"
Type:	ED600	ED240
Free speed:	220 Rpm	110 Rpm
Power:	750W	1500 W
Torque:	360 Nm	420 Nm
Gearbox:	2-stage	3-stage

MEMBRANE REMOVAL AND OVERLAY HEAD



Head with carbide bits.



HEAD NR	TUBE CAPACITY		INSERT	NO. OF INSERTS
	[INCH]	[MM]		
PRRBMH-PF-508	2,000	50,80	PO8	7
PRRBMH-PF-571	2,250	57,15	PO8	7
PRRBMH-PF-603	2,375	60,33	PO8	7
PRRBMH-PF-635	2,500	63,50	PO8	7
PRRBMH-PF-762	3,000	76,20	PO8	9

Cutters and inserts

REGULAR CUTTERS

FOR USE WITHOUT HOLDERS
BIT: HSS and HSS Cobalt

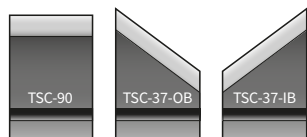

Cutters for MiniMill series

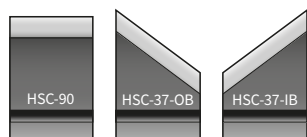

Cutters for HyperMill series

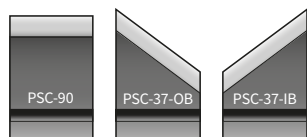

Cutters for PipeMill series

INSERTS

Inserts options:
HSS-Co 5% cobalt
HSS-Co-AN 5% cobalt + ANOVA coating
HSS-M2
HSS-M2-TiN HSS+TiN coating



CI	A	B
mm	5	5

MAT: Carbide
Screw: MHS-2



CI7	A	B
mm	7	7

MAT: Carbide
Screw: MHS-2,7



CS	A	B
mm	9,5	9,5

MAT: HSS 6% Cobalt
Screw: MHS-4



CSZ	A	B
mm	5,8	9,5

MAT: HSS 6% Cobalt
Screw: MHS-2,5



CSS-CB	A	B
mm	6,3	9,5

MAT: HSS 6% Carbide
Screw: MHS-2,5



CSS	A	B
mm	6,3	9,5

MAT: HSS 6% Cobalt
Screw: MHS-2,5



PO8	R
mm	8

MAT: Carbide
Screw: MHS-2,7

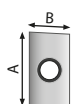

CDI	A	B
mm	18	9,5

MAT: HSS 6% Cobalt
Screw: MHS-4

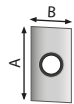

CDI-CB	A	B
mm	18	9,5

MAT: HSS 6% Carbide
Screw: MHS-4

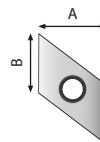

WRIL	A	B
mm	13,5	9,5

MAT: HSS 6% Cobalt
Screw: MHS-4

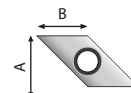

WRK	A	B
mm	10	9,5

MAT: HSS 6% Cobalt
Screw: MHS-4

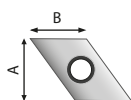

WRI	A	B
mm	13,5	9,5

MAT: HSS 6% Cobalt
Screw: MHS-4

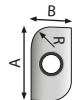

CDJ-2.5*	A	B	R
mm	18	9,5	2,5
CDJ-5	18	9,5	4,7
CDJ-8*	18	9,5	8,0

MAT: HSS 6% Cobalt
Screw: MHS-4
* order only

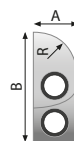

CSWR	A	B	R
mm	6,5	16,5	6

MAT: HSS 6% Cobalt
Screw: MHS-2,5



2CDI	A	B
mm	45	12,7

MAT: HSS 6% Cobalt
Screw: MHS-5

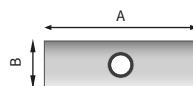

CDK	A	B
mm	25	9,5

MAT: HSS 6% Cobalt
Screw: MHS-5

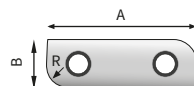

2CDJ-5	A	B	R
mm	45	12,7	4,7

MAT: HSS 6% Cobalt
Screw: MHS-5

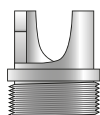

MAT: HSS 6% Cobalt

	MIN	MAX
CSS-100	8,00	12,00
CSS-117	8,60	13,50
CSS-127	9,60	14,50
CSS-145	10,6	16,5

Holders for regular cutter heads

OUTSIDE BEVELING HOLDERS

Standard: 37,5°; other angles only on request

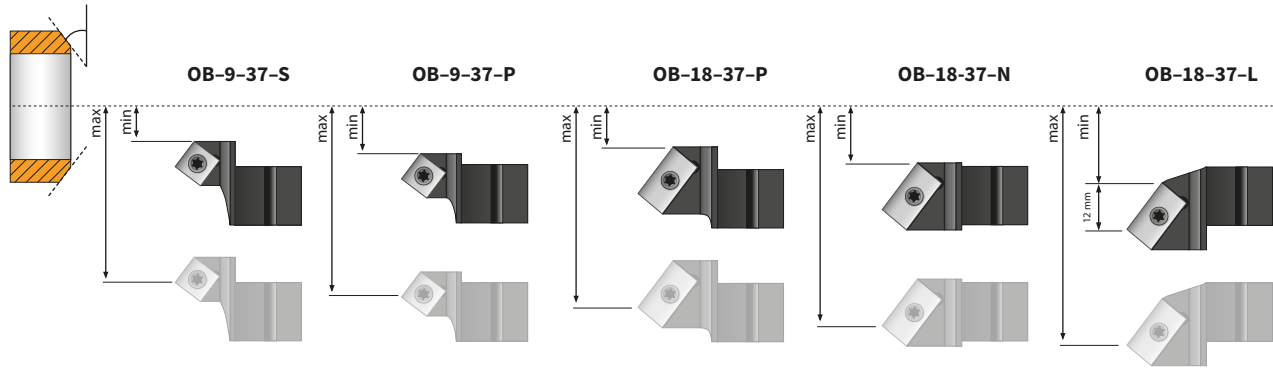

HOLDER NO.	BIT	HEAD	RANGE [MM]		RANGE [INCH]		DEGREE*
			MIN	MAX	MIN	MAX	
OB-9-37-S	CS	60	16,00	26,00	0,630	1,024	20; 30; 37,5 ; 45
		88	16,00	51,00	0,630	2,008	20; 30; 37,5 ; 45
OB-9-37-P	CS	60	24,00	34,00	0,945	1,339	20; 30; 37,5 ; 45
		88	24,00	58,00	0,945	2,283	20; 30; 37,5 ; 45
		106	28,00	72,00	1,102	2,835	20; 30; 37,5 ; 45
OB-18-37-P	CDI	60	24,00	47,00	0,945	1,850	20; 30; 37,5 ; 45
		88	24,00	71,00	0,945	2,795	20; 30; 37,5 ; 45
		106	28,00	85,00	1,102	3,346	20; 30; 37,5 ; 45
		114	31,00	88,00	1,220	3,465	20; 30; 37,5 ; 45
		135	31,00	109,00	1,220	4,291	20; 30; 37,5 ; 45
OB-18-37-L	CDI	175	31,00	149,00	1,220	5,866	20; 30; 37,5 ; 45

HOLDER NO.	BIT	HEAD	RANGE [MM]		RANGE [INCH]		DEGREE*
			MIN	MAX	MIN	MAX	
OB-18-37-N	CDI	60	34,00	56,00	1,339	2,205	20; 30; 37,5 ; 45
		88	34,00	80,00	1,339	3,150	20; 30; 37,5 ; 45
		106	38,00	94,00	1,496	3,701	20; 30; 37,5 ; 45
		114	43,00	101,00	1,693	3,976	20; 30; 37,5 ; 45
		135	43,00	122,00	1,693	4,803	20; 30; 37,5 ; 45
		175	43,00	162,00	1,693	6,378	20; 30; 37,5 ; 45
OB-18-37-L	CDI	60	40,00	63,00	1,575	2,480	20; 30; 37,5 ; 45
		88	40,00	87,00	1,575	3,425	20; 30; 37,5 ; 45
		106	44,00	101,00	1,732	3,976	20; 30; 37,5 ; 45
		114	47,00	104,00	1,850	4,094	20; 30; 37,5 ; 45
		135	47,00	125,00	1,850	4,921	20; 30; 37,5 ; 45
		175	47,00	165,00	1,850	6,496	20; 30; 37,5 ; 45

Holders for regular cutter heads

INSIDE BEVELING HOLDERS

Standard: 37,5°; other angles only on request

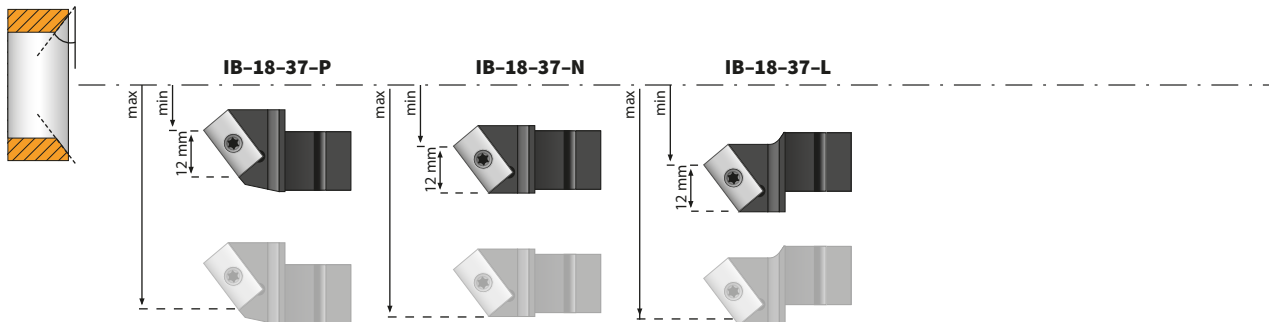

HOLDER NO.	BIT	HEAD	RANGE [MM]		RANGE [INCH]		DEGREE*
			MIN	MAX	MIN	MAX	
IB-18-37-P	CDI	60	35,50	58,00	1,398	2,283	20; 30; 37,5 ; 45
		88	35,50	82,50	1,398	3,248	20; 30; 37,5 ; 45
		106	39,50	96,50	1,555	3,799	20; 30; 37,5 ; 45
		114	42,00	102,00	1,654	4,016	20; 30; 37,5 ; 45
		135	42,00	123,00	1,654	4,843	20; 30; 37,5 ; 45
		175	42,00	163,00	1,654	6,417	20; 30; 37,5 ; 45
IB-18-37-N	CDI	60	44,50	67,50	1,752	2,657	20; 30; 37,5 ; 45
		88	44,50	92,00	1,752	3,622	20; 30; 37,5 ; 45
		106	48,50	106,00	1,909	4,173	20; 30; 37,5 ; 45
		114	51,00	111,00	2,008	4,370	20; 30; 37,5 ; 45
		135	51,00	132,00	2,008	5,197	20; 30; 37,5 ; 45
		175	51,00	172,00	2,008	6,772	20; 30; 37,5 ; 45

HOLDER NO.	BIT	HEAD	RANGE [MM]		RANGE [INCH]		DEGREE*
			MIN	MAX	MIN	MAX	
IB-18-37-L	CDI	60	53,00	76,00	2,087	2,992	20; 30; 37,5 ; 45
		88	53,00	100,00	2,087	3,937	20; 30; 37,5 ; 45
		106	57,00	114,00	2,244	4,488	20; 30; 37,5 ; 45
		114	60,00	120,00	2,362	4,724	20; 30; 37,5 ; 45
		135	60,00	141,00	2,362	5,551	20; 30; 37,5 ; 45
		175	60,00	181,00	2,362	7,126	20; 30; 37,5 ; 45

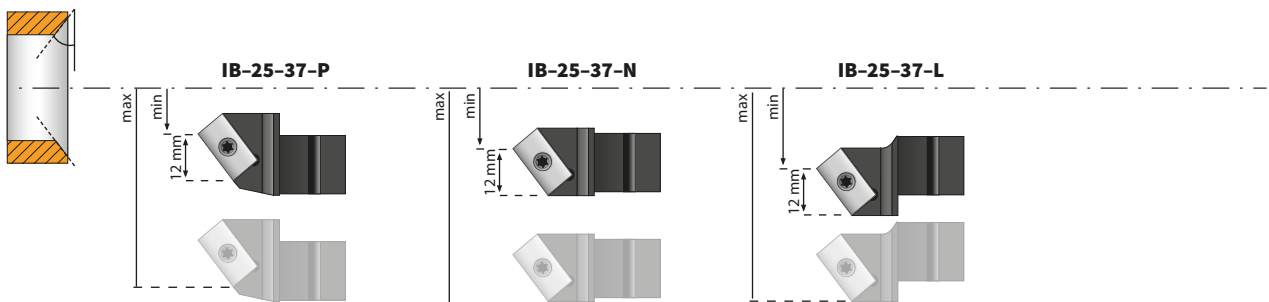

HOLDER NO.	BIT	HEAD	RANGE [MM]		RANGE [INCH]		DEGREE*
			MIN	MAX	MIN	MAX	
IB-25-37-P	CDK	60	35,50	63,00	1,398	2,480	20; 30; 37,5 ; 45
		88	35,50	87,50	1,398	3,444	20; 30; 37,5 ; 45
		106	39,50	101,50	1,555	3,996	20; 30; 37,5 ; 45
		114	42,00	107,00	1,654	4,212	20; 30; 37,5 ; 45
		135	42,00	128,00	1,654	5,039	20; 30; 37,5 ; 45
		175	42,00	168,00	1,654	6,614	20; 30; 37,5 ; 45
IB-25-37-N	CDK	60	44,50	72,50	1,752	2,854	20; 30; 37,5 ; 45
		88	44,50	97,00	1,752	3,818	20; 30; 37,5 ; 45
		106	48,50	111,00	1,909	4,370	20; 30; 37,5 ; 45
		114	51,00	116,00	2,008	4,566	20; 30; 37,5 ; 45
		135	51,00	137,00	2,008	5,393	20; 30; 37,5 ; 45
		175	51,00	177,00	2,008	6,969	20; 30; 37,5 ; 45

HOLDER NO.	BIT	HEAD	RANGE [MM]		RANGE [INCH]		DEGREE*
			MIN	MAX	MIN	MAX	
IB-25-37-L	CDK	60	53,00	81,00	2,087	3,188	20; 30; 37,5 ; 45
		88	53,00	105,00	2,087	4,133	20; 30; 37,5 ; 45
		106	57,00	119,00	2,244	4,685	20; 30; 37,5 ; 45
		114	60,00	125,00	2,362	4,921	20; 30; 37,5 ; 45
		135	60,00	146,00	2,362	5,748	20; 30; 37,5 ; 45
		175	60,00	186,00	2,362	7,322	20; 30; 37,5 ; 45

Holders for regular cutter heads

FACING HOLDERS

Standard: 90,0°

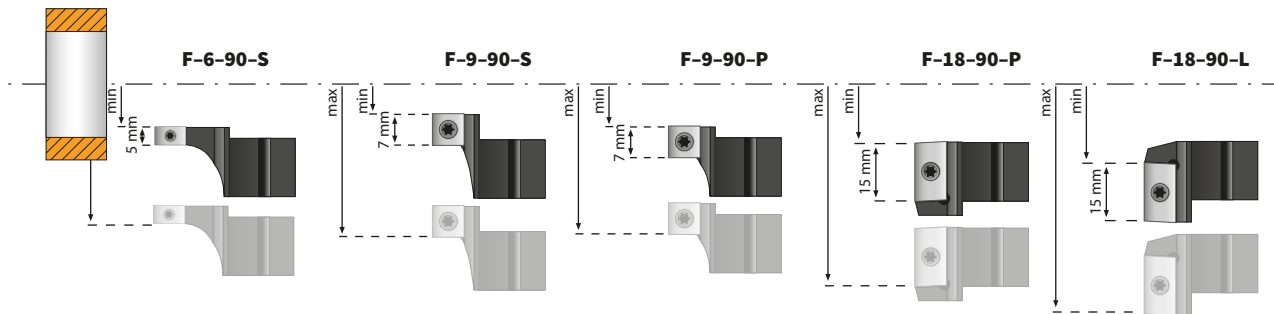

HOLDER NO.	BIT	HEAD	RANGE [MM]		RANGE [INCH]		DEGREE*
			MIN	MAX	MIN	MAX	
F-6-90-S	CSS	60	14,50	24,50	0,571	0,965	90
F-9-90-S	CS	60	16,00	30,00	0,630	1,181	90
		88	24,00	62,00	0,945	2,441	90
F-9-90-P	CS	60	24,00	38,00	0,945	1,496	90
		88	24,00	62,00	0,945	2,441	90
		106	28,00	75,00	1,102	2,953	90
F-18-90-P	CDI	60	24,00	54,00	0,945	2,126	90
		88	24,00	79,00	0,945	3,110	90
		106	28,00	95,00	1,102	3,740	90

HOLDER NO.	BIT	HEAD	RANGE [MM]		RANGE [INCH]		DEGREE*
			MIN	MAX	MIN	MAX	
F-18-90-P	CDI	114	31,00	98,00	1,220	3,858	90
		135	31,00	119,00	1,220	4,685	90
		175	31,00	159,00	1,220	6,260	90
F-18-90-L	CDI	60	33,00	62,00	1,299	2,441	90
		88	33,00	87,00	1,299	3,425	90
		106	37,00	101,00	1,457	3,976	90
		114	38,00	104,00	1,496	4,094	90
		135	38,00	125,00	1,496	4,921	90
		175	38,00	165,00	1,496	6,496	90

FACING HOLDERS

Standard: 90,0°

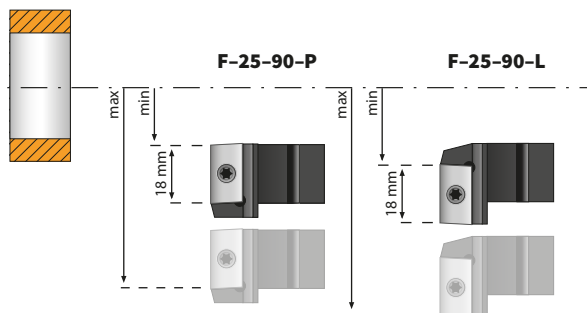

HOLDER NO.	BIT	HEAD	RANGE [MM]		RANGE [INCH]		DEGREE*
			MIN	MAX	MIN	MAX	
F-25-90-P	CDK	60	24,00	61,00	0,945	2,401	90
		88	24,00	86,00	0,945	3,385	90
		106	28,00	102,00	1,102	4,015	90
	CDK	114	31,00	105,00	1,220	4,133	90
		135	31,00	126,00	1,220	4,960	90
		175	31,00	166,00	1,220	6,535	90
F-25-90-L	CDK	60	33,00	69,00	1,299	2,716	90
		88	33,00	94,00	1,299	3,700	90
		106	37,00	108,00	1,457	4,251	90
		114	38,00	111,00	1,496	4,370	90
		135	38,00	132,00	1,496	5,196	90
		175	38,00	172,00	1,496	6,771	90

Holders for regular cutter heads

WELD REMOVAL HOLDERS

STANDARD: 37,5°; OTHER ANGLES ONLY ON REQUEST

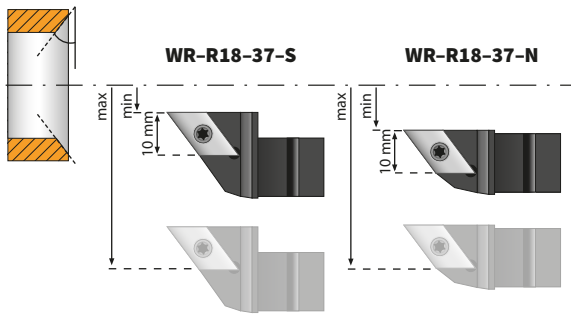

JPREP STRENGTH REMOVAL

SIMULTANEOUS PROCESSING OF THE TUBE AND THE TUBE SHEET.

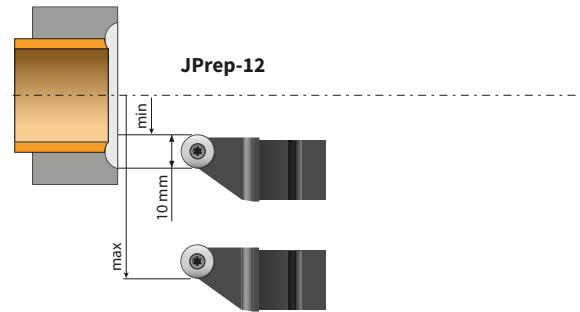

HOLDER NO.	BIT	HEAD	RANGE [MM]		RANGE [INCH]		DEGREE*
			MIN	MAX	MIN	MAX	
WR-R18-37-S	WRI	60	15,50	36,00	0,610	1,417	20; 30; 37,5 ; 45
		88	15,50	61,00	0,610	2,402	20; 30; 37,5 ; 45
		106	19,50	75,00	0,768	2,953	20; 30; 37,5 ; 45
WR-R18-37-N	WRI	60	30,00	50,00	1,181	1,969	20; 30; 37,5 ; 45
		88	30,00	75,00	1,181	2,953	20; 30; 37,5 ; 45
		106	34,00	89,00	1,339	3,504	20; 30; 37,5 ; 45
		114	37,00	94,00	1,457	3,701	20; 30; 37,5 ; 45
		135	37,00	115,00	1,457	4,528	20; 30; 37,5 ; 45
		175	37,00	155,00	1,457	6,102	20; 30; 37,5 ; 45

HOLDER NO.	BIT	HEAD	RANGE [MM]		RANGE [INCH]	
			MIN	MAX	MIN	MAX
JPrep-12	PO12	60	24,00	38,00	0,945	1,496
		88	24,00	62,00	0,945	2,441
		106	28,00	75,00	1,102	2,953
		114	31,00	80,00	1,220	3,150

MiniMill Special Heads

STWRMH

STRENGTH WELD REMOVAL
BIT: HSS 6% Cobalt
DEGREE: 37.5°

Custom designed head dedicated for strength weld removal. The heads are sized per tube diameter and are precisely engineered so that the inserts cannot damage the shaft or locking jaws. Simple, trouble-free set up makes these heads very advantageous.

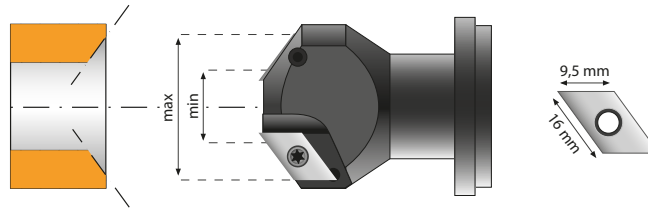

HEAD NR	TUBE CAPACITY			RANGE [INCH]		RANGE [MM]		INSERT	NO. OF INSERTS	SHAFT
	[INCH]	[MM]	BWG	MIN	MAX	MIN	MAX			
STWRMH-145	0,570	14,5	16-23	0,433	1,417	11,00	36,00	WRI	2	801MM#151 10 mm
STWRMH-158	0,625	15,9	16-23	0,492	1,476	12,50	37,50	WRI	2	805MM#151 11 mm
STWRMH-190	0,750	19,05	12-23	0,530	1,46	13,50	37,00	WRI	2	901 MM#151 12,4 mm
STWRMH-222	0,875	22,23	12-23	0,650	1,496	16,50	38,00	WRI	2	905 MM#151 13,9 mm
STWRMH-254	1,000	25,40	10-23	0,732	1,654	18,60	42,00	WRI	2	909 MM#151 16,9 mm
STWRMH-285	1,125	28,58	10-23	0,858	1,772	21,80	45,00	WRI	2	STD Shaft: 20 or 25 mm
STWRMH-317	1,250	31,75	9-23	0,945	1,850	24,00	47,00	WRI	2	STD Shaft: 20 or 25 mm
STWRMH-381	1,500	38,10	8-23	1,142	2,047	29,00	52,00	WRI	2	STD Shaft: 20 or 25 mm
STWRMH-444	1,750	44,45	8-23	1,417	2,244	36,00	57,00	CDI	2	STD Shaft: 20 or 25 mm
STWRMH-508	2,000	50,80	6-23	1,575	2,480	40,00	63,00	CDI	2	STD Shaft: 20 or 25 mm
STWRMH-571	2,250	57,15	6-23	1,811	2,717	46,00	69,00	CDI	2	STD Shaft: 20 or 25 mm
STWRMH-603	2,375	60,33	6-23	1,949	2,854	49,50	72,50	CDI	2	STD Shaft: 20 or 25 mm
STWRMH-635	2,500	63,50	6-23	2,067	2,972	52,50	75,50	CDI	2	STD Shaft: 20 or 25 mm
STWRMH-762	3,000	76,20	6-23	2,579	3,484	65,50	88,50	CDI	2	STD Shaft: 20 or 25 mm
STWRMH-889	3,500	88,90	6-23	3,071	3,976	78,00	101,00	CDI	2	STD Shaft: 20 or 25 mm
STWRMH-900	4,000	101,60	6-23	3,563	4,469	90,50	113,50	CDI	2	STD Shaft: 20 or 25 mm

TFMH

TUBE FACING MILLING HEAD
BIT: HSS 6% Cobalt
DEGREE: 90.0°

A tube facing milling head created for facing tubes made of any type of material. Utilizes 6% cobalt inserts.

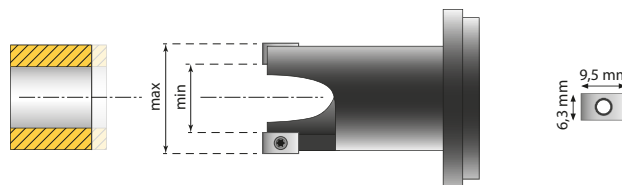

HEAD NR	RURA			RANGE [INCH]		RANGE [MM]		INSERT	NO. OF INSERTS	SHAFT
	[INCH]	[MM]	BWG	MIN	MAX	MIN	MAX			
TFMH-145	0,570	14,48	16-23	0,441	0,870	11,2	22,1	CSZ	2	801 MM#151 Micro 10,0MM
TFMH-158	0,625	15,88	16-23	0,500	0,933	12,70	23,70	CSZ	2	805 MM#151 Micro 11,5 MM
TFMH-190	0,750	19,05	12-23	0,531	1,004	13,50	25,50	CSS	2	901 MM#151 12,4 mm
TFMH-222	0,875	22,23	12-23	0,654	1,063	16,60	27,00	CSS	2	905 MM#151 13,9 mm
TFMH-254	1,000	25,40	11-23	0,764	1,201	19,40	30,50	CSS	2	909 MM#151 16,9 mm
TFMH-285	1,125	28,58	11-23	0,854	1,307	21,70	33,20	CSS	2	915 MM#151 20,0 mm
TFMH-317	1,250	31,75	9-23	0,949	1,366	24,10	34,70	CSS	2	915 MM#151 20,0 mm
TFMH-381	1,500	38,10	9-23	1,197	1,614	30,40	41,00	CSS	2	915 MM#151 20,0 mm
TFMH-444	1,750	44,45	9-23	1,449	1,862	36,80	47,30	CS	2	MM#37
TFMH-508	2,000	50,80	9-23	1,701	2,114	43,20	53,70	CS	2	MM#37

MiniMill Special Heads

OBMH

OUTSIDE BEVEL MILLING HEAD
BIT: HSS 6% Cobalt
DEGREE: 37,5°

Dedicated for the outside beveling of both tubes and pipes. Sized per tube or pipe diameter and angle of required weld bevel. The heads are precisely engineered so that the inserts cannot damage the shaft or locking jaws.

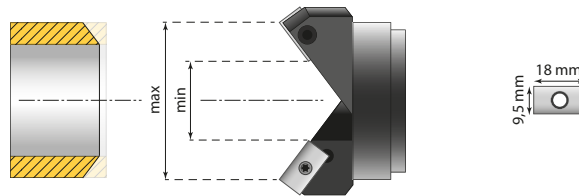

HEAD NR	TUBE CAPACITY			RANGE [INCH]		RANGE [MM]		INSERT	NO. OF INSERTS	SHAFT
	[INCH]	[MM]	BWG	MIN	MAX	MIN	MAX			
OBMH-190	0,750	19,05	14-23	0,5826	0,866	14,80	22,00	CS	2	901 MM#151 12,4 mm
OBMH-222	0,875	22,23	12-23	0,654	1,004	16,60	25,50	CS	2	905 MM#151 13,9 mm
OBMH-254	1,000	25,40	11-23	0,764	1,122	19,40	28,50	CS	2	909 MM#151 16,9 mm
OBMH-285	1,125	28,58	11-23	0,890	1,240	22,60	31,50	CS	2	915 MM#151 20 mm
OBMH-317	1,250	31,75	8-23	0,917	1,732	23,30	44,00	CDI	2	STD Shaft: 20 or 25 mm
OBMH-381	1,500	38,10	6-23	0,984	1,850	25,00	47,00	CDI	2	STD Shaft: 20 or 25 mm
OBMH-444	1,750	44,45	6-23	1,024	1,890	26,00	48,00	CDI	2	STD Shaft: 20 or 25 mm
OBMH-508	2,000	50,80	6-23	1,181	2,047	30,00	52,00	CDI	2	STD Shaft: 20 or 25 mm
OBMH-571	2,250	57,15	6-23	1,417	2,283	36,00	58,00	CDI	2	STD Shaft: 20 or 25 mm
OBMH-603	2,375	60,33	6-23	1,535	2,402	39,00	61,00	CDI	2	STD Shaft: 20 or 25 mm
OBMH-635	2,500	63,50	6-23	1,654	2,559	42,00	65,00	CDI	2	STD Shaft: 20 or 25 mm
OBMH-762	3,000	76,20	6-23	2,165	3,031	55,00	77,00	CDI	2	STD Shaft: 20 or 25 mm
OBMH-889	3,500	88,90	6-23	2,677	3,543	68,00	90,00	CDI	2	STD Shaft: 20 or 25 mm
OBMH-900	4,000	101,60	6-23	3,150	4,016	80,00	102,00	CDI	2	STD Shaft: 20 or 25 mm

MMRBMH

MEMBRANE REMOVAL HEAD
BIT: CARBIDE

Specially designed head for membrane removal and overlay head (cladding removal)

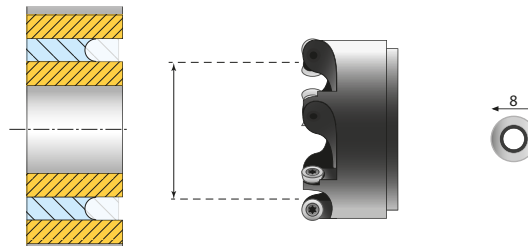

HEAD NR	TUBE CAPACITY		RANGE [INCH]		RANGE [MM]		INSERT	NO. OF INSERTS
	[INCH]	[MM]	MIN	MAX	MIN	MAX		
MMRBMH-254	1,000	25,40	1,000	1,630	25,40	41,40	P08	4
MMRBMH-288	1,125	28,58	1,134	1,764	28,80	44,80	P08	5
MMRBMH-317	1,250	31,75	1,248	1,878	31,70	47,70	P08	5
MMRBMH-381	1,500	38,10	1,500	2,130	38,10	54,10	P08	6
MMRBMH-444	1,750	44,45	1,748	2,378	44,40	60,40	P08	6
MMRBMH-508	2,000	50,80	2,000	2,630	50,80	66,80	P08	7
MMRBMH-571	2,250	57,15	2,252	2,882	57,20	73,20	P08	7
MMRBMH-603	2,375	60,33	2,374	3,004	60,30	76,30	P08	7
MMRBMH-635	2,500	63,50	2,500	3,130	63,50	79,50	P08	7
MMRBMH-762	3,000	76,20	3,000	3,630	76,20	92,20	P08	8
MMRBMH-889	3,500	88,90	3,500	4,130	88,90	104,90	P08	8
MMRBMH-101	4,000	101,60	4,000	4,630	101,60	117,60	P08	9

MiniMill Special Heads

SWROTC

TUBE FACING MILLING HEAD
BIT: HSS 6% Cobalt

A seal weld removal head over tube circumference prior to re-welding the damaged joint without removing the tube.

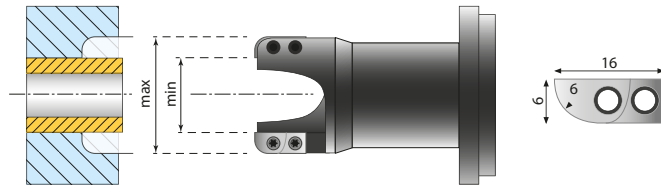

HEAD NR	TUBE CAPACITY		RANGE [INCH]		RANGE [MM]		INSERT	NO. OF INSERTS	SHAFT
	[INCH]	[MM]	MIN	MAX	MIN	MAX			
SWROTC-190	0,750	19,05	0,750	1,222	19,05	31,05	CSWR	2	901 MM#151 12,4 mm
SWROTC-222	0,875	22,23	0,874	1,346	22,20	34,20	CSWR	2	905 MM#151 13,9 mm
SWROTC-254	1,000	25,40	1,000	1,472	25,40	37,40	CSWR	2	909 MM#151 16,9 mm
SWROTC-285	1,125	28,58	1,124	1,596	28,55	40,55	CSWR	2	915 MM#151 20,0 mm
SWROTC-318	1,250	31,7	1,250	1,722	31,75	43,75	CSWR	2	915 MM#151 20,0 mm
SWROTC-381	1,500	38,1	1,500	1,969	38,10	50,01	CSWR	2	915 MM#151 20,0 mm

TFMH-127

TUBE FACING MILLING HEAD
BIT: HSS 6% Cobalt

A seal weld removal head over tube circumference prior to re-welding the damaged joint without removing the tube.

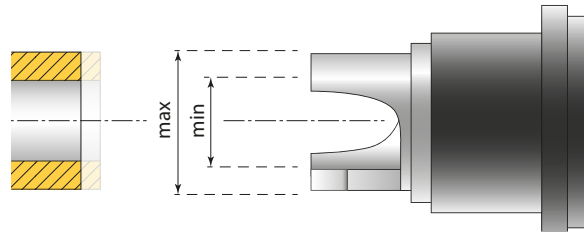

INSERT NR	RANGE [MM]		RANGE [INCH]		SHAFT	SHAFT OD	
	MIN	MAX	MIN	MAX		[MM]	[INCH]
CSS-100	8,00	12,00	0,315	0,472	798MM#151	7,70	0,303
CSS-117	8,60	13,50	0,339	0,531	799MM#151	8,00	0,315
CSS-127	9,60	14,50	0,378	0,571	800MM#151	9,00	0,354
CSS-145	10,6	16,5	0,417	0,650	801MM#151	10,00	0,394

SWRMH

SEAL WELD REMOVAL HEAD
BIT: CARBIDE
DEGREE: 90.0°

Size specific heads designed for seal weld removal on tubes. Suitable for weld removal on carbon, duplex, inconel and other exotic alloys. Utilizes 4 sided carbide inserts.

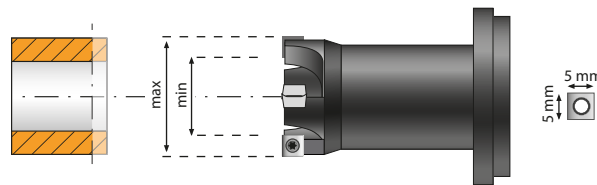

HEAD NR	TUBE CAPACITY			RANGE [INCH]		RANGE [MM]		INSERT	NO. OF INSERTS	SCREW
	[INCH]	[MM]	BWG	MIN	MAX	MIN	MAX			
SWRMH-160	0,625	15,88	17-22	0,500	1,100	12,70	28,00	CI 5x5	4	MHS-2
SWRMH-190	0,750	19,05	11-22	0,510	1,140	13,00	29,00	CI 5x5	4	MHS-2
SWRMH-222	0,875	22,23	10-22	0,710	1,300	18,00	33,00	CI 5x5	4	MHS-2
SWRMH-254	1,000	25,40	8-20	0,810	1,380	20,50	35,00	CI 5x5	4	MHS-2

PrepMill and HyperMill Special Heads

FOR HYPERMILL ADDITIONAL FLANGE OBPM-F IS REQUIRED!

OBPM

OUTSIDE BEVEL MILLING HEAD
BIT: HSS 6% Cobalt
DEGREE: 37,5°

Custom, precisely designed head. Dedicated for the outside beveling of both tubes and pipes. Sized per tube or pipe diameter and angle of required weld bevel. The heads are precisely engineered so that the inserts cannot damage the shaft or locking jaws.

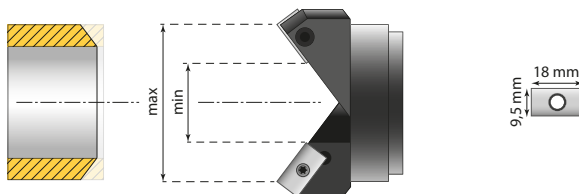

HEAD NR	TUBE CAPACITY			RANGE [INCH]		RANGE [MM]		INSERT	NO. OF INSERTS	SHAFT
	[INCH]	[MM]	BWG	MIN	MAX	MIN	MAX			
OBPM-190	0,750	19,05	14-23	0,5826	0,866	14,80	22,00	CS	2	915 MM#151 20 mm
OBPM-222	0,875	22,23	12-23	0,654	1,004	16,60	25,50	CS	2	STD Shaft: 20 or 25 mm
OBPM-254	1,000	25,40	11-23	0,764	1,122	19,40	28,50	CS	2	STD Shaft: 20 or 25 mm
OBPM-285	1,125	28,58	11-23	0,890	1,240	22,60	31,50	CS	2	STD Shaft: 20 or 25 mm
OBPM-317	1,250	31,75	8-23	0,917	1,732	23,30	44,00	CDI	2	STD Shaft: 20 or 25 mm
OBPM-381	1,500	38,10	6-23	0,984	1,850	25,00	47,00	CDI	2	STD Shaft: 20 or 25 mm
OBPM-444	1,750	44,45	6-23	1,024	1,890	26,00	48,00	CDI	2	STD Shaft: 20 or 25 mm
OBPM-508	2,000	50,80	6-23	1,181	2,047	30,00	52,00	CDI	2	STD Shaft: 20 or 25 mm
OBPM-571	2,250	57,15	6-23	1,417	2,283	36,00	58,00	CDI	2	STD Shaft: 20 or 25 mm
OBPM-603	2,375	60,33	6-23	1,535	2,402	39,00	61,00	CDI	2	STD Shaft: 20 or 25 mm
OBPM-635	2,500	63,50	6-23	1,654	2,559	42,00	65,00	CDI	2	STD Shaft: 20 or 25 mm
OBPM-762	3,000	76,20	6-23	2,165	3,031	55,00	77,00	CDI	2	STD Shaft: 20 or 25 mm
OBPM-889	3,500	88,90	6-23	2,677	3,543	68,00	90,00	CDI	2	STD Shaft: 20 or 25 mm
OBPM-900	4,000	101,60	6-23	3,150	4,016	80,00	102,00	CDI	2	STD Shaft: 20 or 25 mm

PRRBH

MEMBRANE REMOVAL HEAD
BIT: CARBIDE

Specially designed head for membrane removal and overlay head (cladding removal)

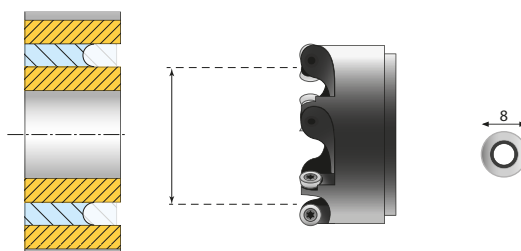

HEAD NR	TUBE CAPACITY		RANGE [INCH]		RANGE [MM]		INSERT	NO. OF INSERTS
	[INCH]	[MM]	MIN	MAX	MIN	MAX		
PRRBH-254	1,000	25,40	1,000	1,630	25,40	41,40	PO8	4
PRRBH-288	1,125	28,58	1,134	1,764	28,80	44,80	PO8	5
PRRBH-317	1,250	31,75	1,248	1,878	31,70	47,70	PO8	5
PRRBH-381	1,500	38,10	1,500	2,130	38,10	54,10	PO8	6
PRRBH-444	1,750	44,45	1,748	2,378	44,40	60,40	PO8	6
PRRBH-508	2,000	50,80	2,000	2,630	50,80	66,80	PO8	7
PRRBH-571	2,250	57,15	2,252	2,882	57,20	73,20	PO8	7
PRRBH-603	2,375	60,33	2,374	3,004	60,30	76,30	PO8	7
PRRBH-635	2,500	63,50	2,500	3,130	63,50	79,50	PO8	7
PRRBH-762	3,000	76,20	3,000	3,630	76,20	92,20	PO8	8
PRRBH-889	3,500	88,90	3,500	4,130	88,90	104,90	PO8	8
PRRBH-101	4,000	101,60	4,000	4,630	101,60	117,60	PO8	9

PrepMill and HyperMill Special Heads

STWRPM

STRENGTH WELD REMOVAL
BIT: HSS 6% Cobalt
DEGREE: 37.5°

Custom designed head dedicated for strength weld removal. The heads are sized per tube diameter and are precisely engineered so that the inserts cannot damage the shaft or locking jaws. Simple, trouble-free set up makes these heads very advantageous.

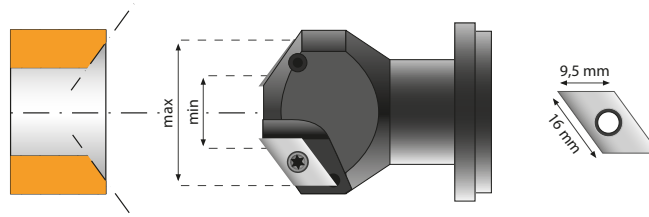

HEAD NR	TUBE CAPACITY			RANGE [INCH]		RANGE [MM]		INSERT	NO. OF INSERTS	SHAFT
	[INCH]	[MM]	BWG	MIN	MAX	MIN	MAX			
STWRPM-190	0,750	19,05	12-23	0,530	1,46	13,50	37,00	WRI	2	STD Shaft: 20 mm
STWRPM-222	0,875	22,23	12-23	0,650	1,496	16,50	38,00	WRI	2	STD Shaft: 20 or 25 mm
STWRPM-254	1,000	25,40	10-23	0,732	1,654	18,60	42,00	WRI	2	STD Shaft: 20 or 25 mm
STWRPM-285	1,125	28,58	10-23	0,858	1,772	21,80	45,00	WRI	2	STD Shaft: 20 or 25 mm
STWRPM-317	1,250	31,75	9-23	0,945	1,850	24,00	47,00	WRI	2	STD Shaft: 20 or 25 mm
STWRPM-381	1,500	38,10	8-23	1,142	2,047	29,00	52,00	WRI	2	STD Shaft: 20 or 25 mm
STWRPM-444	1,750	44,45	8-23	1,417	2,244	36,00	57,00	CDI	2	STD Shaft: 20 or 25 mm
STWRPM-508	2,000	50,80	6-23	1,575	2,480	40,00	63,00	CDI	2	STD Shaft: 20 or 25 mm
STWRPM-571	2,250	57,15	6-23	1,811	2,717	46,00	69,00	CDI	2	STD Shaft: 20 or 25 mm
STWRPM-603	2,375	60,33	6-23	1,949	2,854	49,50	72,50	CDI	2	STD Shaft: 20 or 25 mm
STWRPM-635	2,500	63,50	6-23	2,067	2,972	52,50	75,50	CDI	2	STD Shaft: 20 or 25 mm
STWRPM-762	3,000	76,20	6-23	2,579	3,484	65,50	88,50	CDI	2	STD Shaft: 20 or 25 mm
STWRPM-889	3,500	88,90	6-23	3,071	3,976	78,00	101,00	CDI	2	STD Shaft: 20 or 25 mm
STWRPM-900	4,000	101,60	6-23	3,563	4,469	90,50	113,50	CDI	2	STD Shaft: 20 or 25 mm

TFPM

TUBE FACING MILLING HEAD
BIT: HSS 6% Cobalt
DEGREE: 90.0°

A tube facing milling head created for facing tubes made of any type of material. Utilizes 6% cobalt inserts.

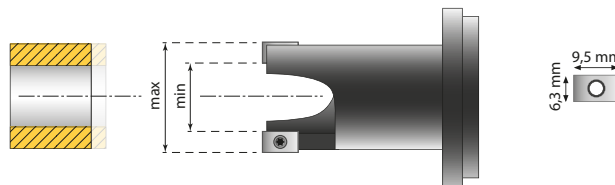

HEAD NR	TUBE CAPACITY			RANGE [INCH]		RANGE [MM]		INSERT	NO. OF INSERTS	SHAFT
	[INCH]	[MM]	BWG	MIN	MAX	MIN	MAX			
TFPM-285	1,125	28,58	11-23	0,854	1,307	21,70	33,20	CSS	2	STD Shaft 20 mm
TFPM-317	1,250	31,75	9-23	0,949	1,366	24,10	34,70	CSS	2	STD Shaft 20 mm
TFPM-381	1,500	38,10	9-23	1,197	1,614	30,40	41,00	CSS	2	STD Shaft: 20 or 25 mm
TFPM-444	1,750	44,45	9-23	1,449	1,862	36,80	47,30	CS	2	STD Shaft: 20 or 25 mm
TFPM-508	2,000	50,80	9-23	1,701	2,114	43,20	53,70	CS	2	STD Shaft: 20 or 25 mm

Holders for PanelMill heads

It is highly recommended to use inserts made by KRAIS with ALNOVA coating by OERLIKON on this machine.

OUTSIDE BEVELING HOLDERS

Cutting edge length: 12 mm, standard angle: 37,5° (others on request)

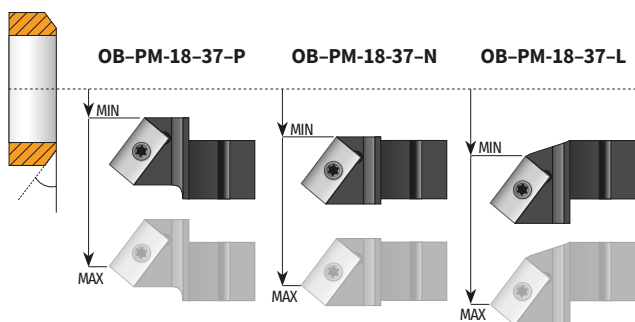

HOLDER NO.	BIT	HEAD	RANGE [MM]		RANGE [INCH]		DEGREE*
			MIN	MAX	MIN	MAX	
OB-PM-18-37-P	CDI	64	0,00	47,00	0,000	1,850	30; 37,5
	CDI	99	0,00	85,00	0,000	3,346	30; 37,5
OB-PM-18-37-N	CDI	64	11,00	56,50	0,433	2,224	30; 37,5
	CDI	99	11,00	95,00	0,433	3,740	30; 37,5
OB-PM-18-37-L	CDI	64	20,00	65,50	0,787	2,579	30; 37,5
	CDI	99	20,00	104,00	0,787	4,094	30; 37,5

OUTSIDE BEVELING HOLDERS

Cutting edge length: 10 mm, standard angle: 37,5° (others on request)

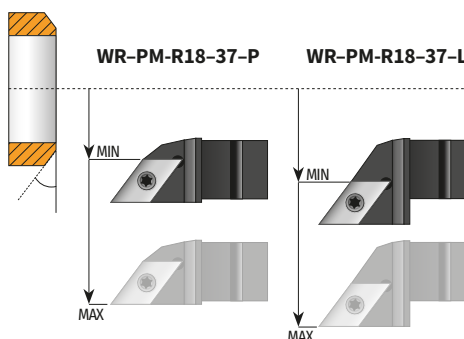

HOLDER NO.	BIT	HEAD	RANGE [MM]		RANGE [INCH]		DEGREE*
			MIN	MAX	MIN	MAX	
WR-PM-R18-37-P	WRIL	64	28,00	62,00	1,102	2,441	30; 37,5
WR-PM-R18-37-L	WRIL	64	36,00	70,00	1,417	2,756	30; 37,5
WR-PM-R18-37-L	WRIL	99	36,00	116,00	1,417	4,567	30; 37,5

INSIDE BEVELING HOLDERS

Cutting edge length: 12 mm, standard angle: 37,5° (others on request)

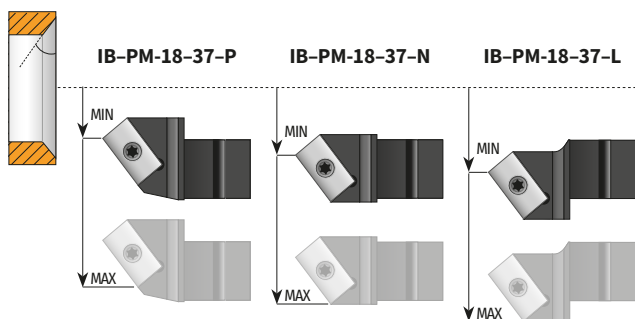

HOLDER NO.	BIT	HEAD	RANGE [MM]		RANGE [INCH]		DEGREE*
			MIN	MAX	MIN	MAX	
IB-PM-18-37-P	CDI	64	10,00	56,00	0,394	2,205	30; 37,5
	CDI	99	10,00	95,00	0,394	3,740	30; 37,5
IB-PM-18-37-N	CDI	64	20,00	65,00	0,787	2,559	30; 37,5
	CDI	99	20,00	104,00	0,787	4,094	30; 37,5
IB-PM-18-37-L	CDI	64	35,00	79,00	1,378	3,110	30; 37,5
	CDI	99	35,00	115,00	1,378	4,528	30; 37,5

FACING HOLDERS

Cutting edge length: 15 mm, standard angle: 90,0°

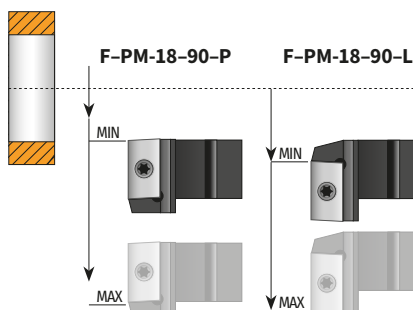

HOLDER NO.	BIT	HEAD	RANGE [MM]		RANGE [INCH]		DEGREE*
			MIN	MAX	MIN	MAX	
F-PM-18-90-P	CDI	64	0,00	53,00	0,000	2,087	90
	CDI	99	0,00	88,00	0,000	3,465	90
F-PM-18-90-L	CDI	64	20,00	80,00	0,787	3,150	90
	CDI	99	20,00	116,00	0,787	4,567	90



Pipe Beveling Machines

MiniLathe

The most powerful machine within its size range on the market today. It utilizes a powerful 3.5 HP pneumatic motor, entirely engineered and manufactured by KRAIS for the largest end prep systems.

- ▶ Innovative 6-point locking system ensures maximum stability during all machining operations.
- ▶ Self-centering 2.75" one-piece locking shaft with built-in jaws eliminates the issue of broken or loose retaining springs and O-rings.
- ▶ Only one mandrel and 10 jaw sets are needed to cover the machine's entire range.
- ▶ Wide clamps produce superior clamping force for chatter-free end preps.
- ▶ Fully portable for both on-site and fab-shop work.
- ▶ Available for sale or rent.



STANDARD WORKING RANGE		FEED STROKE	POWER	FREE SPEED	TORQUE		
APPLICATION RANGE	LOCKING RANGE (ID)						
72 - 406 mm	70 - 400 mm	50 mm	3,5 Hp	5 Rpm	12500 Nm		
2,800 - 16,000"	2,755 - 15,700"	2"			9219 Ft.Lbs		
70 cfm	2,2 m ³ /min	90 PSI	6,2 Bar	25 x 13 x 12"	640 x 330 x 300 mm	75 Lbs	35 kg

LOCKING RANGES WITH STANDARD JAWS

JAWS: ML-42

RANGE [MM]		RANGE [INCH]		SEGMENT		
MIN	MAX	MIN	MAX	A	B	C
70	85	2,756	3,346			
85	100	3,346	3,937	ML-42-A-75		
100	115	3,937	4,528	ML-42-A-150		
115	130	4,528	5,118	ML-42-A-225		
130	145	5,118	5,709	ML-42-A-300		
145	160	5,709	6,299	ML-42-A-375		
160	175	6,299	6,890			ML-42-C
175	190	6,890	7,480	ML-42-A-75		ML-42-C
190	205	7,480	8,071	ML-42-A-150		ML-42-C
205	220	8,071	8,661	ML-42-A-225		ML-42-C
220	235	8,661	9,252	ML-42-A-300		ML-42-C
235	250	9,252	9,843	ML-42-A-375		ML-42-C
250	265	9,843	10,433		ML-42-B	ML-42-C
265	280	10,433	11,024	ML-42-A-75	ML-42-B	ML-42-C
280	295	11,024	11,614	ML-42-A-150	ML-42-B	ML-42-C
295	310	11,614	12,205	ML-42-A-225	ML-42-B	ML-42-C
310	325	12,205	12,795	ML-42-A-300	ML-42-B	ML-42-C
325	340	12,795	13,386	ML-42-A-375	ML-42-B	ML-42-C
340	355	13,386	13,976	ML-42-A-300 ML-42-A-150	ML-42-B	ML-42-C
355	370	13,976	14,567	ML-42-A-300 ML-42-A-225	ML-42-B	ML-42-C
370	385	14,567	15,157	ML-42-A-375 ML-42-A-225	ML-42-B	ML-42-C
385	400	15,157	15,748	ML-42-A-375 ML-42-A-300	ML-42-B	ML-42-C

OPTIONAL SERVO DRIVE



EV-2000 SYNC

The machine can be driven by modern, high-tech KRAIS AC servo motor for controlled axis motion. They ensure highly accurate and smooth machine motion. The motor has a rated output of 3 kW, rated speed of 2000 r/min, and rated torque of 14.3 Nm.

OPTIONAL HYDRAULIC DRIVE







PDH MOTOR

Optional super strong hydraulic motor. Constructed on the basis of a small hydraulic motor and multistage planetary gear box. HyperLathe version generates 11 rpm and up to 8200 Nm (6050 Ft.Lbs) torque on cutter blade at constant cutting speed.

MiniLathe

AVAILABLE HOLDERS

Facing	Inside bevelling and boring	Outside bevelling	J-Prep	Compound bevelling
				
F-45-90 BIT: 2CDI	IB-45-37 IB-45-10 BIT: 2CDI	OB-45-45 OB-45-37 OB-45-30 OB-45-10 BIT: 2CDI	JP-45-45 JP-45-37 JP-45-30 BIT: 2CDJ-5	CB-1037 (OTHERS ON REQUEST) BIT: CB-45

ADVANTAGES OF MINILATHE

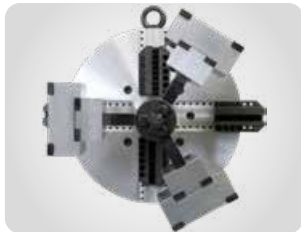

6 POINT LOCKING JAWS
150 mm (5,9") shaft, assures rigidity when machining heavy wall pipe. The jaws are fully contained within the shaft with no need for retaining springs or O-rings that easily brake or get lost.



POWERFUL MOTOR UNIT
Powerful and efficient drives dedicated for our Lathe series beveling machines. 11 rpm and 3850 Nm (2840 Ft.Lbs) torque on the cutter blade is a standard feature.



HEAVY DUTY PENDANT
Machine is equipped with a heavy duty pendant. This can be attached to both sides of the motor for operator convenience.



SLIDE BEARING
As an option we can supply a bronze slide bearing that delivers more stability and rigidity while machining a very hard materials and heavy wall pipes.

EXAMPLE TOOL APPLICATION



The machine optionally can be equipped with a double-sided yoke with removable extensions so that two people can freely install into the processed pipe.

PipeLathe 24

PipeLathe 24 is strong and versatile facing lathe in the KRAIS line, engineered for precision machining of pipes up to 24" (600 mm) OD, including the most demanding materials such as P91, Super Duplex, SMO-254, Inconel, and high-alloy stainless steels.

The new generation introduces a fundamental upgrade: full multi-drive compatibility, with the ability to work using hydraulic, electric PMSM, or pneumatic drives, either in single-motor or dual synchronized motor configuration.

This gives operators the freedom to optimise torque, speed, and cutting dynamics depending on the application - from heavy wall machining to clean, highly repeatable bevels in stainless steels.

THREE FULLY SUPPORTED DRIVE OPTIONS

- 】 Hydraulic drive - extreme torque for heavy-wall machining and hard alloys.
- 】 Electric PMSM drive - high efficiency, constant torque across the full speed range, ideal for stainless steels.
- 】 Pneumatic drive - lightweight, dynamic, EX-safe, and easy to service.



SINGLE- OR DUAL-MOTOR OPERATION FOR ALL DRIVES

Two synchronized drives significantly increase torque capacity and ensure stable cutting conditions on wall thicknesses up to 3 inches.



STANDARD WORKING RANGE		FEED STROKE	POWER (ONE PNEUMATIC)	FREE SPEED (ONE PNEUMATIC)	TORQUE (ONE PNEUMATIC)		
APPLICATION RANGE	LOCKING RANGE						
180 - 609 mm	175 - 600 mm	60 mm	3,5 hp	5 Rpm	12500 Nm		
7,0 - 24,0"	6,889 - 23,6"	2,4"			9219 Ft.lbs		
AIR USE		AIR PRESSURE		BODY DIMENSIONS		BODY WEIGHT	
85 cfm	2,8 m ³ /min	90 PSI	6,2 Bar	38 x 22 x 22"	950 x 550 x 500 mm	495 Lbs	225 kg

KEY FEATURES OF PIPELATHE 24

- 】 High rigidity and mechanical stability
- 】 150 mm (5.9") one-piece locking shaft with integrated jaws — no springs, no O-rings.
- 】 6-point locking system providing maximum stiffness and vibration-free cutting.
- 】 One mandrel and six jaw sets cover the entire working range.

Wide machining capability

- 】 10–37° compound bevel
- 】 J-Prep (all standard angles)
- 】 V-bevel, U-bevel, facing, boring
- 】 Internal and external beveling
- 】 Up to 3" wall thickness

DRIVE CONFIGURATIONS



HYDRAULIC DRIVE (SINGLE OR DUAL)

Provides the highest torque output and unmatched stability. Ideal for:

- 】 Heavy wall up to 3"
- 】 Cutting operations with strong heat build-up



EV2000-SYNC ELECTRIC DRIVE (SINGLE OR DUAL)

Constant torque even at low RPM

- 】 Smooth, quiet operation
- 】 Excellent surface finish and high process repeatability
- 】 Perfect for stainless steels and high-alloy applications







PNEUMATIC DRIVE (SINGLE OR DUAL)

Best choice in EX-restricted zones

- 】 Lightweight, dynamic acceleration
- 】 Easy to maintain and economical to operate

PipeLathe 24

AVAILABLE HOLDERS

Facing	Inside bevelling and boring	Outside bevelling	J-Prep	Compound bevelling
				
F-45-90 BIT: 2CDI	IB-45-37 IB-45-10 BIT: 2CDI	OB-45-45 OB-45-37 OB-45-30 OB-45-10 BIT: 2CDI	JP-45-45 JP-45-37 JP-45-30 BIT: 2CDJ-5	CB-1037 (OTHERS ON REQUEST) BIT: CB-45

HYDRAULIC POWER-PACK



For advanced, heavy-duty applications, we offer high-performance hydraulic power units (HPUs) designed for seamless integration with the hydraulic-driven version of the PipeLathe 24.

ADVANTAGES OF PIPELATHE 24



HEAVY DUTY DESIGN
The PipeLathe24 is engineered specifically to excel in the harshest industrial environments. At the heart of this series is a robust, extended steel spindle which serves as the foundation for maximum structural rigidity.

Unlike conventional designs where the locking shaft is only partially seated within a softer aluminum body—a flaw that creates stress points and leads to adverse vibration due to excessive tension—our locking shaft is fully mounted and supported within the hardened steel spindle.

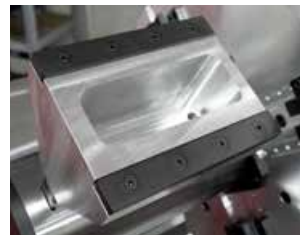

6 POINT LOCKING JAWS
150 mm (5,9”) shaft, assures rigidity when machining heavy wall pipe. The jaws are fully contained within the shaft with no need for retaining springs or O-rings that easily brake or get lost.



HEAVY DUTY PENDANT
Machine is equipped with a heavy duty pendant. This can be attached to both sides of the motor for operator convenience.

LOCKING RANGES WITH STANDARD JAWS

JAWS: PL-42

RANGE [MM]		RANGE [INCH]		SEGMENT		
MIN	MAX	MIN	MAX	A	B	C
175,0	200,0	6,890	7,874			
200,0	225,0	7,874	8,858	PL-42-A-125		
225,0	250,0	8,858	9,843	PL-42-A-250		
250,0	275,0	9,843	10,827	PL-42-A-375		
275,0	300,0	10,827	11,811	PL-42-A-500		
300,0	325,0	11,811	12,795	PL-42-A-500 PL-42-A-125		
325,0	350,0	12,795	13,780	PL-42-A-500 PL-42-A-250		
350,0	375,0	13,780	14,764		PL-42-B	
375,0	400,0	14,764	15,748	PL-42-A-125	PL-42-B	
400,0	425,0	15,748	16,732	PL-42-A-250	PL-42-B	
425,0	450,0	16,732	17,717	PL-42-A-375	PL-42-B	
450,0	475,0	17,717	18,701	PL-42-A-500	PL-42-B	
475,0	500,0	18,701	19,685			PL-42-C
500,0	525,0	19,685	20,669	PL-42-A-125		PL-42-C
525,0	550,0	20,669	21,654	PL-42-A-250		PL-42-C
550,0	575,0	21,654	22,638	PL-42-A-375		PL-42-C
575,0	600,0	22,638	23,622	PL-42-A-500		PL-42-C

EXAMPLE TOOL APPLICATION



PipeLathe 40

- Powerful hydraulic drive generating 14500 Nm (10800 ft.lbs) of torque on the cutter blade.
- Variable speed control 0-5 RPM. There is no need for an extra gear box that reduces the RPM and multiplies the torque. It comes as standard!
- 150 mm (5,9") locking shaft with built-in jaws eliminates the issue of broken or loosening retaining springs and o-rings.
- An innovative 6-point locking system with wide clamps assures maximum stability during machining.
- Only one mandrel and a set of six jaws cover the entire working range.
- Fully portable for on-site and fab-shop work. Available for sale or rent.



MACHINE PERFORMANCE

PipeLathe 40 is the biggest internal mounted machine from all KRAIS Lathe tools. It allows for machining tubes up to 40" (600 mm) OD. Picture shows PipeLathe 40 machining 36" tube.

STANDARD WORKING RANGE		FEED STROKE	POWER	FREE SPEED	TORQUE		
APPLICATION RANGE	LOCKING RANGE						
305 - 1016 mm	300 - 972 mm	60 mm	3,5 hp	5 Rpm	12500 Nm		
12,0" - 40,0"	11,8" - 38,3"	2,4"			9219 Ft.lbs		
AIR USE		AIR PRESSURE		BODY DIMENSIONS		BODY WEIGHT	
85 cfm	2,8 m ³ /min	90 PSI	6,2 Bar	38 x 22 x 22"	950 x 550 x 500 mm	495 Lbs	225 kg

LOCKING RANGES WITH STANDARD JAWS

JAWS: PL-42

RANGE [MM]		RANGE [INCH]		SEGMENT				
MIN	MAX	MIN	MAX	A	B	C	D	E
300	325	11,8	12,8	PL-42-A-500 PL-42-A-125				
325	350	12,8	13,8	PL-42-A-500 PL-42-A-250				
350	375	13,8	14,8		PL-42-B			
375	400	14,8	15,7	PL-42-A-125	PL-42-B			
400	425	15,7	16,7	PL-42-A-250	PL-42-B			
425	450	16,7	17,7	PL-42-A-375	PL-42-B			
450	475	17,7	18,7	PL-42-A-500	PL-42-B			
475	500	18,7	19,7			PL-42-C		
500	525	19,7	20,7	PL-42-A-125		PL-42-C		
525	550	20,7	21,7	PL-42-A-250		PL-42-C		
550	575	21,7	22,6	PL-42-A-375		PL-42-C		
575	600	22,6	23,6	PL-42-A-500		PL-42-C		
593	622	23,3	24,5	PL-42-A-500 PL-42-A-125		PL-42-C		
621	647	24,4	25,5	PL-42-A-500 PL-42-A-250		PL-42-C		

RANGE [MM]		RANGE [INCH]		SEGMENT				
MIN	MAX	MIN	MAX	A	B	C	D	E
646	671	25,4	26,4	PL-42-A-500 PL-42-A-375		PL-42-C		
667	693	26,3	27,3			PL-42-C	PL-42-D	
692	716	27,2	28,2	PL-42-A-125		PL-42-C	PL-42-D	
715	739	28,1	29,1	PL-42-A-250		PL-42-C	PL-42-D	
738	762	29,1	30,0	PL-42-A-375		PL-42-C	PL-42-D	
761	786	30,0	30,9	PL-42-A-500		PL-42-C	PL-42-D	
787	811	31,0	31,9			PL-42-C		PL-42-E
810	834	31,9	32,8	PL-42-A-125		PL-42-C		PL-42-E
833	856	32,8	33,7	PL-42-A-250		PL-42-C		PL-42-E
856	879	33,7	34,6	PL-42-A-375		PL-42-C		PL-42-E
878	903	34,6	35,6	PL-42-A-500		PL-42-C		PL-42-E
902	925	35,5	36,4	PL-42-A-500 PL-42-A-125		PL-42-C		PL-42-E
924	949	36,4	37,4	PL-42-A-500 PL-42-A-250		PL-42-C		PL-42-E
948	972	37,3	38,3	PL-42-A-500 PL-42-A-375				PL-42-E

SlimFit Split Frame Clamshells



KRAIS SFSF portable SLIM FIT Clamshell series are designed for strength and easy handling. Each of the machine from the SFSF series have a height of 3,248" (82,5 mm) up to 24" and 4,47" (113,7 mm) up to 48" and a width of 2.5" (63,5 mm) resulting narrow body low profile design that makes the SFSF series the ideal choice in tight spaces.

- 】 15 Standard models cover a range from 1." (33,4 mm) to 48" (1219 mm) OD
- 】 Pneumatic, hydraulic and electric drive options are available.
- 】 Motor mount on keyways to prevent the motor to twist and potential damage on gear ring.
- 】 Several different drive options are available to best position the motor for a specific machining application
- 】 All pneumatic and electric motors are design and Manufactured by KRAIS after 20 years experience of manufacturing pneumatic drives for boiler and heat exchangers tube rolling motors.
- 】 SFSF series clamshells can be equipped a wide range of accessories to increase performance and expand capabilities.
- 】 Adjustable locator pads minimize the number of locators.



FEATURES



Choice of 3 positions with different travel length tool holder with heat treated slights.



Lever type tripper module for operator safety.



Steel plates on the back part for machine squaring on the pipe.

AIR TREATMENT MODULE



Optional module (ATM) provides air treatment capability for KRAIS pneumatic powered split frames.

SlimFit Split Frame Clamshells

General technical machine information to enable to make the right choice to suit your application.

For our SFSF clamshells we offer a wide range of pneumatic, electric made 100% in house and hydraulic choose by our engineers or upon customer preference. Such a big range and variety of parameters allow us to select motor to achieve to best and most post suitable cutting speed to machined pipe material and diameter.

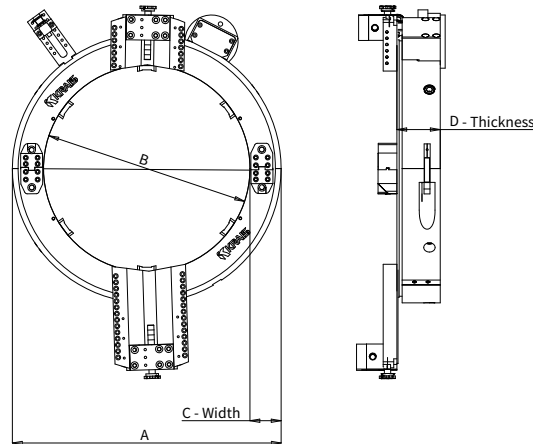

MODEL	PIPE CAPACITY			DIMENSIONS								LOCATOR PADS	GEAR RING RATIO
	UNIT	MIN OD	MAX OD	UNIT	A	B	C	D	1" SLIDE SWING	3" SLIDE SWING	6" SLIDE SWING		
SFSF-0204	NPS	2,000	4,000	[inch]	9,685	4,736	2,500	3,248	12,165	16,165	-	4	4,6:1
	Metric	60,32	127,00	[mm]	246,00	120,30	63,50	82,50	309,00	410,60	-		
SFSF-0256	NPS	2,500	6,000	[inch]	11,831	6,858	2,500	3,248	14,339	18,339	-	4	5,7:1
	Metric	73,02	168,27	[mm]	300,50	174,20	63,50	82,50	364,20	465,80	-		
SFSF-0358	NPS	3,500	8,000	[inch]	13,819	8,846	2,500	3,248	16,339	20,339	26,339	4	6,7:1
	Metric	101,60	219,07	[mm]	351,00	224,70	63,50	82,50	415,00	516,60	669,00		
SFSF-0410	NPS	4,500	10,000	[inch]	16,220	11,236	2,500	3,248	18,756	22,756	28,756	4	7,8:1
	Metric	127,00	273,05	[mm]	412,00	285,40	63,50	82,50	476,40	578,00	730,40		
SFSF-0612	NPS	6,000	12,000	[inch]	18,150	13,236	2,500	3,248	20,843	24,843	30,843	4	8,9:1
	Metric	168,27	323,85	[mm]	461,00	336,20	63,50	82,50	529,40	631,00	783,40		
SFSF-0814	NPS	8,000	14,000	[inch]	19,488	14,484	2,500	3,248	22,063	26,063	32,063	6	9,5:1
	Metric	219,07	355,60	[mm]	495,00	367,90	63,50	82,50	560,40	662,00	814,40		
SFSF-1016	NPS	10,000	16,000	[inch]	21,457	16,484	2,500	3,287	24,102	28,102	34,102	6	10,6:1
	Metric	273,05	406,40	[mm]	545,00	418,70	63,50	83,50	612,20	713,80	866,20		
SFSF-1218	NPS	12,000	18,000	[inch]	23,504	18,484	2,500	3,287	26,224	30,224	36,224	6	11,6:1
	Metric	323,85	457,20	[mm]	597,00	469,50	63,50	83,50	666,10	767,70	920,10		
SFSF-1420	NPS	14,000	20,000	[inch]	25,472	20,848	2,500	3,287	28,150	32,150	38,150	6	12,6:1
	Metric	355,60	508,00	[mm]	647,00	520,30	63,50	83,50	715,00	816,60	969,00		
SFSF-1624	NPS	16,000	24,000	[inch]	29,488	24,406	2,500	3,287	32,268	36,268	42,268	10	14,6:1
	Metric	406,40	609,60	[mm]	749,00	619,90	63,50	83,50	819,60	921,20	1073,60		
SFSF-2028	NPS	20,000	28,000	[inch]	33,900	28,750	2,757	4,476	36,516	40,516	46,516	10	16,9:1
	Metric	508,00	711,20	[mm]	861,10	730,30	65,40	113,70	927,50	1029,10	1181,50		
SFSF-2432	NPS	24,000	32,000	[inch]	38,150	33,000	2,757	4,476	40,787	44,787	50,787	10	19:1
	Metric	609,60	812,80	[mm]	969,00	838,20	65,40	113,70	1036,00	1137,60	1290,00		
SFSF-2836	NPS	28,000	36,000	[inch]	42,150	37,000	2,757	4,476	44,913	48,913	54,913	10	21:1
	Metric	711,20	914,40	[mm]	1070,60	939,80	65,40	113,70	1140,80	1242,40	1394,80		
SFSF-3442	NPS	34,000	42,000	[inch]	48,150	43,000	2,757	4,476	50,906	54,906	60,906	10	24,2:1
	Metric	863,60	1066,80	[mm]	1223,00	1092,20	65,40	113,70	1293,00	1394,60	1547,00		
SFSF-4048	NPS	40,000	48,000	[inch]	54,402	49,525	2,757	4,476	57,276	61,276	67,276	12	27,3:1
	Metric	1016,00	1219,20	[mm]	1381,80	1251,00	65,40	113,70	1454,80	1556,40	1708,80		

SFSF clamshells motors

PNEUMATIC MOTORS



MOTOR	RIGHT-ANGLE	SPEED	POWER	TORQUE	AIR CONSUMPTION		AIR PRESSURE	
		RPM	HP	NM	LT/MIN	CFM	BAR	PSI
B50-100X	-	200	1,3	70	1300	55	6,2	90
B50-115-RA	YES	115	1,3	186	1300	55	6,2	90
B50-210-RA	YES	210	1,3	102	1300	55	6,2	90
B50-290-RA	YES	290	1,3	74	1300	55	6,2	90
HM-198	-	198	2,2	186	2200	75	6,2	90
HM-252	-	252	2,2	150	2200	75	6,2	90
HM-379	-	379	2,2	105	2200	75	6,2	90
HM-498	-	498	2,2	83	2200	75	6,2	90
K72-LT-90	YES	90	2,2	405	2200	75	6,2	90
K73-LT-190	YES	190	2,2	200	2200	75	6,2	90
PD248U	-	185	3,5	416	2800	95	6,2	90
PD348U	-	60	3,5	1250	2800	95	6,2	90

HYDRAULIC MOTOR



MOTOR	SPEED	POWER	TORQUE	OIL PRESSURE		MIN. OIL FLOW RATE	
	RPM	HP	NM	BAR	PSI	LT/MIN	GPM
HTB-165	343	16,7	273	190	2750	57	15

ELECTRIC MOTORS



PDEC-3200 DUDE 2000 K90Exxx

MOTOR	REVERSIBLE	RIGHTANGLE	MOTOR SPEED	POWER	TORQUE	VOLTAGE
			RPM	WATT	OUT	VOLT
PDEC-3200/100	-	-	100	3200	800 Nm	110/230
PDEC-3200/145	-	-	145	3200	540 Nm	110/230
PDEC-3200/185	-	-	185	3200	420 Nm	110/230
DUDE-2000-4-speed	YES	-	120, 210, 380, 650	2000	240 Nm	110/230
K90E90	-	YES	90	1150	510 Nm	110/230
K90E190	-	YES	190	1150	260 Nm	110/230
K90E280	-	YES	280	1150	190 Nm	110/230

HIGH-END ELECTRIC SERVO DRIVE

EV-2000 SYNC

The machine can be driven by modern, high-tech KRAIS AC servo motor for controlled axis motion. They ensure highly accurate and smooth machine motion.

The motor has a rated output of 3 kW, rated speed of 2000 r/min, and rated torque of 14.3 Nm.



HYDRAULIC POWER PACK

For advanced, heavy-duty applications, we offer high-performance hydraulic power units—perfectly suited for operation with the Spin Air tube extraction and collapsing system.



RECOMMENDATIONS

Only proposal and subject to change upon customer requirement and application

PNEUMATIC MOTORS

UNIT	MOTOR*	POWER	WEIGHT
		HP	KG
SF-4	B50-100X	1,3	11
SF-6	HM-252	2,2	17
SF-8	HM-252	2,2	20
SF-10	HM-252	2,2	27
SF-12	HM-252	2,2	23
SF-14	HM-198	2,2	28
SF-16	HM-198	2,2	32
SF-18	K72-LT-90	2,2	36
SF-20	K72-LT-90	2,2	39
SF-24	PD248U	3,5	52
SF-28	PD248U	3,5	95
SF-32	PD248U	3,5	107
SF-36	PD248U	3,5	118
SF-42	PD248U	3,5	137
SF-48	PD248U	3,5	153

HYDRAULIC MOTORS

UNIT	MOTOR*	POWER	WEIGHT
		HP	KG
SF-16	HTB-165	16,7	32
SF-18	HTB-165	16,7	36
SF-20	HTB-165	16,7	39
SF-24	HTB-165	16,7	52
SF-28	HTB-165	16,7	95
SF-32	HTB-165	16,7	107
SF-36	HTB-165	16,7	118
SF-42	HTB-165	16,7	137
SF-48	HTB-165	16,7	153

ELECTRIC MOTORS

First choice electric drive: PDEC-3200 - high-torque motor with built-in controller for precise speed control. Similar to servo motors, this drive does not slow down and does not tighten under load, but generates up to 5 times more torque than a servo motor which translates into high machining stability. Offers additionally a bunch of indicators: for overload, overheating and brush worn.

UNIT	MOTOR*	POWER	WEIGHT
		WATT	KG
SF-4	PDEC	3200	11
SF-6	PDEC	3200	17
SF-8	PDEC	3200	20
SF-10	PDEC	3200	27
SF-12	PDEC	3200	23
SF-14	PDEC	3200	28
SF-16	PDEC	3200	32

Clamshell K70 Drives

The KRAIS 70 series pneumatic drive motors are the perfect option for all your clamshell needs. They have undergone more than 20 years of rigorous field testing that guarantee's quality and maximum tool life.

The KRAIS 70 series motors and associated spare parts have been designed to be compatible with Cleco 75 series Nutrunners. This allows convenient parts interchangeability of existing motors as used by E.H.Wachs, D.L.Ricci / Hydratight, H&S and other popular clamshell manufacturers.

Both right angle and Inline versions are available.



Cleco® is a registered trademark of Apex Brands, Inc.

DL Ricci® and Hydratight® are a registered trademark of Enerpac

E.H. Wachs® is a registered trademark of ITW, Inc.

H&S® is a registered trademark of Climax

MODEL NUMBER	REVERSIBLE	SQUARE DRIVE	TORQUE		FREE SPEED	LENGTH		WEIGHT		HEAD HEIGHT		ANGLE HEAD SIZE
			FT.LBS.	NM	RPM	IN	MM	LBS	KG	IN	MM	
RIGHT ANGLE VERSION												
K75-RL-3V-375	Yes	1/2"	82	111	375	19,35	491	12,7	5,8	2,5	64	V
K75-RL-3V-280	Yes	1/2"	104	141	280	19,35	491	12,7	5,8	2,5	64	V
K75-RL-3V-190	Yes	1/2"	140	190	190	19,35	491	12,7	5,8	2,5	64	V
K75-RL-3V-152	Yes	1/2"	180	244	152	19,35	491	12,7	5,8	2,5	64	V
K75-RL-3V-100	Yes	1/2"	283	384	101	20,10	511	16,5	6,4	2,5	64	V
K75-RL-3V-50	Yes	1/2"	544	738	50	20,10	511	16,5	6,4	2,5	64	V
K75-NL-3V-190	No	1/2"	165	225	190	19,35	491	12,7	5,8	2,5	64	V
IN LINE VERSION												
L75-RL-488	Yes	1/2"	63	86	488	11,00	279	8,8	4,0	2,5	64	-
L75-RL-364	Yes	1/2"	80	108	364	11,00	279	8,8	4,0	2,5	64	-
L75-RL-247	Yes	1/2"	108	146	247	11,00	279	8,8	4,0	2,5	64	-
L75-RL-198	Yes	1/2"	138	188	198	11,00	279	8,8	4,0	2,5	64	-
L75-RL-131	Yes	1/2"	218	295	131	13,40	340	10,0	4,6	2,5	64	-
L75-RL-65	Yes	1/2"	418	567	65	13,40	340	10,0	4,6	2,5	64	-
L75-NL-247	No	1/2"	127	225	247	11,00	279	8,8	4,0	2,5	64	-

Where: R - reversible | N - non reversible | L - lever valve | V - angle head | xxx - free speed

Air use: air inlet NPT: 1/2"; minimal hose ID: 1/2", 70 scfm

MOUNTING FLANGE



Our mounting flange is manufactured to align with popular E.H.Wachs or D.L.Ricci/Hydratight machines. Custom mounting flanges can be manufactured upon request.

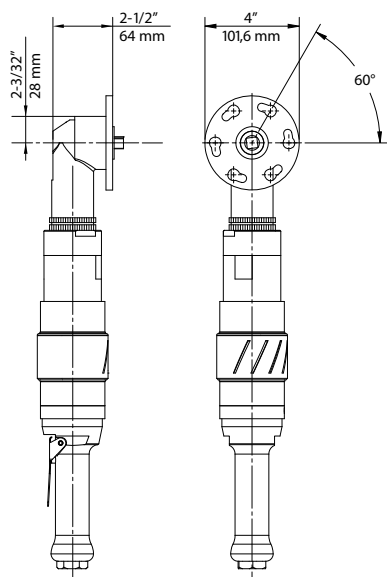

FLEXIBLE CONFIG

KRAIS 70 Series Drives are available in both right angle and inline configurations. Electric and Hydraulic options are also available. Please consult factory.



Reaction ring for SFSF clamshells

KRAIS SFSF REACTION RING IS PATENT PENDING! ALL RIGHTS RESERVED



For super heavy applications with super heavy wall and/or hard alloy pipes, consider our ORR to enhance axial and linear stability. We manufacture the ORR steel ring, which mounts on the rear of the aluminium ring. The ORR is also equipped with 4 steel location stabilizers to enhance the range and rigidity of the machine for those heavy duty applications. The ORR dramatically increases the axial stability and rigidity when cutting and/or bevelling. This solution can help to save time and expense for clamshells completely made out of steel – ask your representative for more details.



SFSF-1624 with ORR mounted on the 24" pipe schedule 120.



ORR mounted on the rear on the existing threaded holes in the aluminium ring.

SFSF clamshells add-ons

TOOL SLIDES

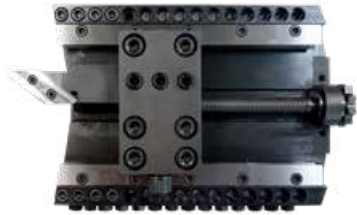

KRAIS Tool Slides are rugged and built for strength and durability tool slides. Standard sizes are 1", 3" and 6". Other on request. Out-of-round and axial-feed tool slides are also available. Built with the same quality: for strength and durability as other KRAIS tool slides. KRAIS Slide construction dramatically eases tool slide mounting and locating.

BCS - BRIDGE CROSS SLIDES

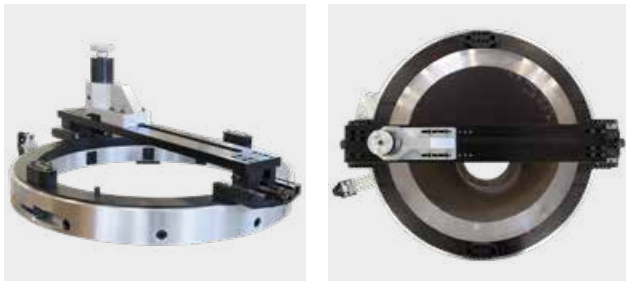

Bridge Cross Slides are available for all KRAIS Split Frame SlimFit series machines. Whether flange facing or single point heavy wall machining, the BCS quickly and easily bolts onto the split frame ring.

BCS NUMBER	RANGE [MM]		RANGE [INCH]	
	MIN	MAX	MIN	MAX
BCS-0814	203,2	355,6	8,000	14,000
BCS-1416	355,6	406,4	14,000	16,000
BCS-1618	406,4	457,2	16,000	18,000
BCS-1820	457,2	508,0	18,000	20,000
BCS-2024	508,0	609,6	20,000	24,000
BCS-2832	609,6	812,8	24,000	32,000
BCS-3236	812,8	914,4	32,000	36,000
BCS-3642	914,4	1066,8	36,000	42,000
BCS-4248	1066,8	1117,6	42,000	44,000

SUPPORT HINGE



Accessory for convenient folding and unfolding of the device. It also allows the use of cranes and lifts that make work easier.

SFSF-CBA UNIVERSAL COUNTERBORE ATTACHMENT



Designed for the precision counterboring of tube and pipe inside diameters. The Universal counterbore is manufactured with both 6" (SFSF-CBA-150) and 10" (SFSF-CBA-254) long sleeves, and attaches directly to all KRAIS clamshells. The Universal Counterbore Attachment utilizes a simple and effective hand wheel to precisely control the counterboring process. Both versions (6" and 10") can be mounted directly to the tool slide or Bridge Cross Slide.

SFSF-SCBA SWIVEL HEAD COUNTERBORING ATTACHMENT



Engineered for precision ID counterboring, the Swivel Head Attachment also supports flange facing, OD beveling, and grooving. Available with 6" (SFSF-SCBA-150) or 10" (SFSF-SCBA-254) sleeves, it integrates directly with all KRAIS Split Frame SlimFit clamshells. Featuring a manual hand wheel for precise feed control, both versions mount to standard tool slides or Bridge Cross Slides.

OUT OF ROUND TOOL SLIDES



Out of round tool slides - can be solution for all misshapen tubes and pipes. Out of round slides feature durable springs and tracking module that follows the contours of a deformed or less than perfectly round pipe. Built with the same quality: for strength and durability as other KRAIS tool slides.

DEADMAN SWITCH

Ergonomic Deadman Switch for Clamshell machines; ensures instantaneous fail-safe motor cutout for enhanced operator safety during pipe machining.



SFSF clamshells bits and holders

HSS CUTTERS

All cutters are made out of regular High Speed Steel. All of them are also available with increased content of Cobalt. Sever holders are available in two standard lengths: 200 and 160 mm. For other shapes please send your request.

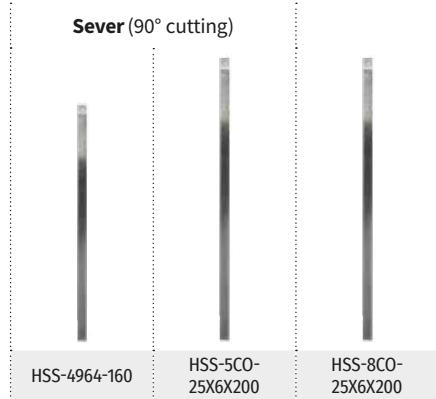

CUTTING BITS FOR USING WITH HOLDERS

Inserts are made out of High Speed Steel with 6% Cobalt and are available with ALNOVE hard coating also. For other tool bits please send your request.



SEVER HOLDERS (90° CUTTING)

Sever holders are made in two lengths: 225 and 180 mm. Twin sets have a special rotated bits for better chip removal. Another lengths are available on special request.

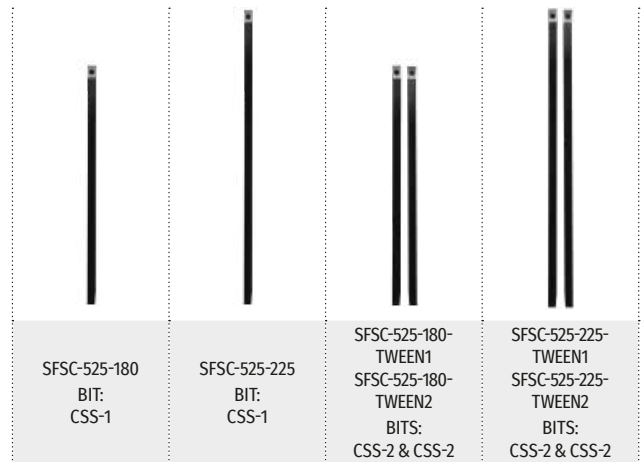

BEVELING HOLDERS

High quality, wide range of holders to work with KRAIS inserts. For other tool bits please send your request.





Flange Management

Manual FlangeMill

Basic, simple and cost-effective solution for ID mount flange facing. It is a quick and easy way to reface a damaged flat, grooves in pipe flanges on site. Manual FlangeMill size and body is designed and built to allow quick and convenient processing of small flanges in awkward or dangerous locations.

With its robust cage-type frame, the MFM ensures exceptional stiffness and precision, unmatched by other hand-operated flange milling machines in the market.

TOOL SWING DIAMETERS

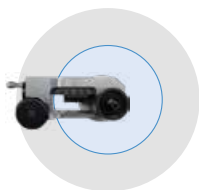

FACING RANGE

BODY SWING DIAMETER



FACING RANGE	LOCKING RANGE	MAX V TOOL TRAVEL	MAX H TOOL TRAVEL	BODY SWING DIAMETER		
30 – 350 mm	25,4 - 254,0 MM	10 MM	55 MM	457,2 MM		
1,750 – 14,000"	1 - 10"	0,395"	2,165"	18"		
DRIVE	BODY WIDTH		BODY LENGTH		BODY WEIGHT	
Manual	6,5"	165 mm	12,8"	325 mm	19,4 Lbs	8,8 kg

MFM TOOL BITS AND HOLDER



Manual Flange Mill uses one just type of holders: MFMH-7-L and MFMH-7-R with carbide insert CI7 (screw MHS-2,7)

CI7	A	B
mm	7	7

MFM ADVANTAGES



PRECISE DEPTH ADJUSTMENT
The tool depth can be adjusted (10 mm stroke) thru spindle to define cut depth and the correct finish.



EASE OF USE
The tool arm is rotated by hand using a worm-gear mechanism to provide a perfect spiral finish.



SMOOTH OPERATION
Quick adjustment handle to move the cutter to groove position



MACHINING IN EVERY POSITION
Manual FlangeMill can be freely rotated to work in every position. Remachining damaged flat, grooves and raised faced flanges on site is possible in every position.

TOOLING CHART

HOLDER	INSERT	SCREW	TORX
MFMH-7-L	CI7	MHS-2,7	TX-8
MFMH-7-R	CI7	MHS-2,7	TX-8

EXAMPLE TOOL APPLICATION



MFM-OMM Module

Outside mounting module for MFM

Expand the capabilities of your KRAIS Manual FlangeMill with the MFM-OMM conversion module. This compact and purpose-built solution enables secure outside mounting, allowing you to face flanges even in situations where internal mounting is not possible—such as with very small diameter flanges or restricted access areas.

With the MFM-OMM, there's no need to invest in additional mini facers or dedicated outside-mount tools. The module lets you easily switch between internal and external mounting configurations without compromising on performance or precision.

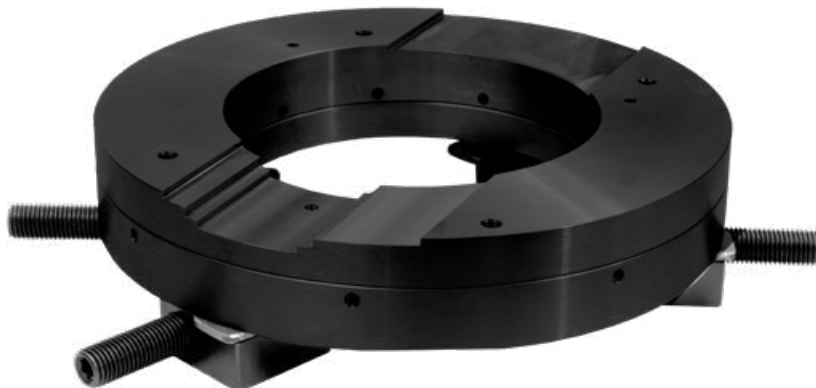

FEATURES

- ▶ **Rigidity** - significantly greater compared to mini flange facers, which are used on small-diameter miniature shafts that tend to bend under the pressure during the rotational force of a long arm.
- ▶ **Cost-effective** - eliminates the need for additional, expensive tools
- ▶ **Versatile** - quick and easy switching between mounting setups
- ▶ **Compact design** - ideal for small flanges and hard-to-reach locations

WORKING PARAMETERS FOR MANUAL FLANGEMILL WITH THE MODULE						
FACING RANGE	OD LOCKING RANGE		FEED STROKE	ADJUSTABLE JAWS		
0 to 127 mm	95,3 to 155,4 mm		31,70 MM	4		
0" to 5"	3,752" to 6,118"		1,248"			
DRIVE	BODY WIDTH		BODY LENGHT		BODY WEIGHT	
Manual	6,5"	165 mm	12,8"	325 mm	19,4 Lbs	8,8 kg

The MFM-OMM is designed exclusively for the Manual FlangeMill 14.

TOOL SWING DIAMETERS

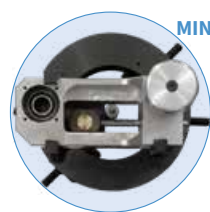

Tool without crank, with bit in position 0 mm



Tool with crank, bit in position 127 mm

OUTSIDE-MOUNTED - READY TO FACE



The MFM-OMM module securely installed on a pipe flange with the Manual FlangeMill. Designed for field use, this setup allows precise facing of small flanges directly from the outside—ideal for tight or inaccessible locations.

QUICK CONVERSION

Switching your Manual FlangeMill to outside mounting is fast and simple – just tighten four clamps and you're ready to face flanges from the outside. No need for disassembly or additional tools.



Manual FlangeMill Long

Long version of simple and cost-effective solution for ID mount flange facing. It is a quick and easy way to reface a damaged flat, grooves in pipe flanges on site. The L(ong) version FlangeMill size and body is designed and built to allow quick and convenient processing of mid sized flanges in awkward or dangerous locations.



TOOL SWING DIAMETERS

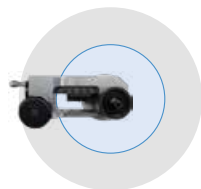

FACING RANGE

BODY SWING DIAMETER

FACING RANGE	LOCKING RANGE	MAX V TOOL TRAVEL	MAX H TOOL TRAVEL	BODY SWING DIAMETER		
51 – 650 mm	51 - 550 MM	10 MM	55 MM	757 MM		
2,01 – 25,60"	2,01 - 21,65"	0,395"	2,165"	30"		
DRIVE	BODY WIDTH		BODY HEIGHT		BODY WEIGHT	
Manual	6,5"	165 mm	18,7"	475 mm	19,4 Lbs	8,8 kg

MFM TOOL BITS AND HOLDER



Manual Flange Mill uses one just type of holders: MFMH-7-L and MFMH-7-R with carbide insert C17 (screw MHS-2,7)

C17 mm	A	B
	7	7

MFM ADVANTAGES



PRECISE DEPTH ADJUSTMENT
The tool depth can be adjusted (10 mm stroke) thru spindle to define cut depth and the correct finish.



EASE OF USE
The tool arm is rotated by hand using a worm-gear mechanism to provide a perfect spiral finish.



SMOOTH OPERATION
Quick adjustment handle to move the cutter to groove position



MACHINING IN EVERY POSITION
Manual FlangeMill can be freely rotated to work in every position. Remachining damaged flat, grooves and raised faced flanges on site is possible in every position.

TOOLING CHART

HOLDER	INSERT	SCREW	TORX
MFMH-7-L	C17	MHS-2,7	TX-8
MFMH-7-R	C17	MHS-2,7	TX-8

MFF-125, Mini Flange Facer

Highly efficient and lightweight flange facing machine – among the most compact options available today.

- ▶ Minimal clearance required
- ▶ Suitable for flat and raised face flanges
- ▶ Reinforced stainless steel body for enhanced machine stability
- ▶ Robust aluminum facing head, bolstered by multiple bearings
- ▶ Durable mandrel shaft with a secure jaw set for firm mounting
- ▶ Precision-engineered, hardened, and ground tool slides
- ▶ Available with a 1.3 Hp pneumatic drive or 750 W electric motor, equipped with a multi-stage planetary gearbox

PREMIUM COMPONENTS

- ▶ The pneumatic motor is fully equipped with a filter, lubricator, and flow control system.
- ▶ Streamlined, low-profile drive system designed to deliver exceptional power-to-weight efficiency.
- ▶ Built with a sturdy main body, heavy-duty bearings, sealed lubrication, and a solid mounting system for reliable performance.



FACING RANGE		LOCKING RANGE		VERTICAL FEED STROKE		MACHINING FEED RATE		POWER	
20 – 125 mm		20 – 88 mm		13 mm		0,125 to 0,5 mm		1,3 Hp	
0.787 – 4.921"		0.787 – 3.465"		0,5"		0,005 to 0,019"			
AIR USE		WEIGHT		HEIGHT		LENGTH		SWING DIAMETER	
55 cfm	1,3 m³/min	23,81 Lbs	10,80 kg	14,5"	372,0 mm	11,8"	300 mm	8,86"	225 mm

AUTOMATIC FEED



The tool is equipped with automatic feed system. The feed rate is set in a simple and quick manner.



FEED TRIPPERS

The machine is equipped with four trippers, allowing to make four feed rates to produce cores and fine surfaces. Using two or more trippers simulates the gramophone groove.

- 1 strike 0,125 mm per rev / 203 rev per 1"
- 2 strikes 0,250 mm oer rev / 101 rev per 1"
- 3 strikes 0,375 mm per rev / 67 rev per 1"
- 4 strikes 0,500 mm per rev / 51 rev per 1"

MFF-125, Mini Flange Facer

EASY SETUP



The device has clear markings that help to precisely set the required machining and grooving depth.

RIGID LOCKING SYSTEM



Precise flange machining is also achieved thanks to the three jaws with six locking points, which hold it very securely inside the tube.



Handy depth feed locking system to prevent accidental movement of the handle during flange processing.

TOOL HOLDERS RANGES

MFF-125 is a low clearance flange facing machine. To achieve this multiple tool holders are required to cover full range.

HOLDER	INSERT	SCREW	TORX
MFF-V11-L	CI-3-1	MHS-4	TX-15
MFF-V11-P			

MFF-125-E

Electric version of regular tool. A standard machine covers the same flange sizes and comes with the same cutting head.

The electric motor, made by Makita with 3 stage planetary gear box made by KRAIS has variable speed control and produce enormous torque. Is interchangeable with pneumatic drive and can be purchased separately at any time. Also available with battery driven motor!

Free Speed..... 115 RPM
Power..... 750 W
Torque..... 360 Nm (266 Ft.Lbs)



BATTERY OPTION

The machine is also available with a portable electric drive 18 Volt 5.2 Ah 93.6 Wh Li-Ion battery. The machine can operate up to 15-20 minutes on one battery.

Machining itself of one flange takes about 3-4 minutes of motor operation, so the operating time on one battery may suffice on 3-4 flanges. It is possible to have many charged batteries. Comfortable and easy to use in any place where compressed air and electricity is not available or even impossible to use as for example oil refinery.



NBFF – Narrow Body Flange Face

*Patent pending

NBFF – the flange facing machine with a slim line gantry profile for mounting in tight spaces. An operator can mount NBFF tool on-site within demanding conditions such as flanges close to walls or pipe racks.

The unique design of NBFF allows the operator to mount the machine and perform a repair in locations that popular, standard equipment could not fit. The machine conforms to all the necessary standards and is extremely easy to use. Light and robust to quickly mount and repair damaged faces on flanges. NBFF can maximize production and uptime in all flange management jobs.



SUPER NARROW BODY

Thanks to unique, a true narrow design NBFF tool is fully usable within demanding conditions such as flanges close to walls or pipe racks.



	FACING RANGE [MM]		FACING RANGE [INCH]		CLAMPING RANGE [MM]		CLAMPING RANGE [INCH]		MAX. SWING DIAMETER		TOOL POST TRAVEL		FREE SPEED	POWER	
	MIN	MAX	MIN	MAX	MIN	MAX	MIN	MAX	[MM]	[INCH]	[MM]	[INCH]	[RPM]	[KW]	[HP]
NBFF-115	0	125	0"	4,921	89	170	3,504	6,693	125	4,921	62,5	2,461	100	0,97	1,3
NBFF-160	0	185	0"	7,283	89	280	3,504	11,024	185	7,283	92,5	3,642	115	1,6	2,2
NBFF-300	0	310	0"	12,205	108	356	4,252	14,016	310	12,205	155	6,102	85	1,6	2,2
NBFF-600															

	AIR USE		DIMENSIONS		WEIGHT	
	[CFM]	[M ³ /MIN]	[MM]	[INCH]	[KG]	[LBS]
NBFF-115	55	1,3	65 (100) x 460 x 260	2,55" (3,93") x 18,11" x 10,23"	25	55,11
NBFF-160	75	2,2	70 (100) x 510 x 340	2,75" (3,93") x 20,07" x 13,38"	27	59,5
NBFF-300	75	2,2	70 (100) x 510 x 470	2,75" (3,93") x 20,07" x 18,50"	32	70,5
NBFF-600						

FEED RATES

Feed rates pitch mm			
0,5	0,75	1*	1,25
Grooves per inch			
104	69	52	41

* standard feed screw supplied with machine

CHOICE OF THREE

All versions of NBFF deliver the same advantage over standard flange facers: despite working size all are narrow and fit perfectly in tight spaces.



TOOLING CHART

HOLDER	INSERT	SCREW	TORX
NBFF-C17	C17	MHS-2,7	TX-8

NBFF – Narrow Body Flange Facer

STANDARD LOCKING SYSTEM



The standard locking system consists of two jaws. One of them is a stabilizing jaw with two adjustable screws to fit the outer diameter of the flange. The second jaw has three clamping screws. Both jaws are equipped with pair top pads for levelling on the sealing surface of the flange. Pads at the bottom, are for tension the machine to the flange surface. Pads help to fix the machine in any position and protect it from falling out of the flange in case of a collision.

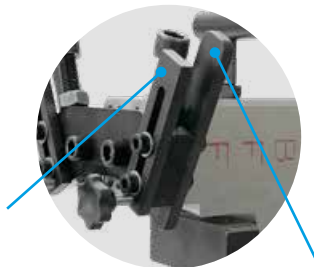

Pads at the bottom, are for tension the machine to the flange surface and protect it from falling out of the flange in case of a collision.

Top pads are for levelling on the sealing surface of the flange.

FLANGE2FLANGE LOCKING OPTION



Additional, special flange type locking system is made to suit the application more. NBFF machine is still mounted on the flange outside diameter, but the locking system is equipped with additional studs to be mounted in the flange holes to provide easy operation and perfect centring.

REAL LIFE EXAMPLE



Example of really tight flange – NBFF is the only tool suitable here.

NBFF IN ACTION



NBFF-E

NBFF-E is electric version of NBFF. A standard machine covers the same flange sizes and comes with the same cutting head. The electric motor, made by Makita with 3 stage planetary gear box made by KRAIS has variable speed control and produce enormous torque. Is interchangeable with pneumatic drive and can be purchased separately at any time.

Free Speed..... 115 RPM
 Power..... 750 W
 Torque..... 360 Nm (266 Ft.Lbs)



BATTERY OPTION

The machine is also available with a portable electric drive 18 Volt 5.2 Ah 93.6 Wh Li-Ion battery. The machine can operate up to 15-20 minutes on one battery. Machining itself of one flange takes about 3-4 minutes of motor operation, so the operating time on one battery may suffice on 3-4 flanges. It is possible to have many charged batteries. Comfortable and easy to use in any place where compressed air and electricity is not available or even impossible to use as for example oil refinery.



OMFM-305

The OMFM-305 is a high-performance, externally mounted machine tool designed for demanding flange machining applications. With its lightweight yet super-rigid construction, the OMFM-305 combines portability with the heavy-duty strength required for precision machining of various flange faces, seal grooves, weld preparations, and counterbores. Its robust design, featuring heavy-duty steel and aluminum components, ensures exceptional durability and reliability in the toughest environments.

KEY FEATURES:

- ▶ Externally mounted, lightweight yet heavy-duty machine.
- ▶ Heavy-duty steel/aluminum construction for durability and precision.
- ▶ High rigidity due to cast steel body and steel body plate.
- ▶ Continuous groove facing feed with 2-speed gearbox for precision finishes.
- ▶ Swivel tool post for grooves, RTJ flanges, and bevels.
- ▶ Complete toolkit with CE certification.



STANDARD WORKING RANGE		FACING FEEDS		FREE SPEED	POWER		
FACING RANGE	LOCKING RANGE	COARSE FEED	FINE FEED				
0 - 305 mm	50,8 - 305,4 mm	0,5 mm (0,020") / Revolution	0,125 mm (0,005") / Revolution	30 Rpm	2,2 Hp		
0" to 12"	2" - 12"	50 Grooves per inch	203 Grooves per inch		1,6 kW		
AIR USE		MACHINE WEIGHT		DRIVE WEIGHT			
75 cfm	2,2 m ³ /min	43 kg	95 Lbs	5 kg	11,0 Lbs		
				SHIPPING BOX		SHIPPING WEIGHT	
				75 x 55 x 35 cm	30" x 22" x 14"	86 kg	189 Lbs

COMPLETE TOOLING PACKAGE

The OMFM-305 comes with a comprehensive toolkit, including all necessary tools, inserts, an air filter lubricator, a hose connection, mounting feet, and extensions. The machine is supplied with a storage and shipping box for easy transport and protection. Additionally, the package includes a CE certificate, packing list, and user manual, ensuring compliance with industry standards and providing operators with all the information needed for safe and effective use.

TOOLING CHART

HOLDER	INSERT	SCREW	TORX
IMFM24-V11-L	CIV-11-3-1	MHS-4	TX-15
IMFM24-V11-N	CIV-11-3-1	MHS-4	TX-15
IMFM24-V11-P	CIV-11-3-1	MHS-4	TX-15

OMFM-305

SWIVEL TOOL

Swivel tool post for grooves, RTJ flanges, and bevels

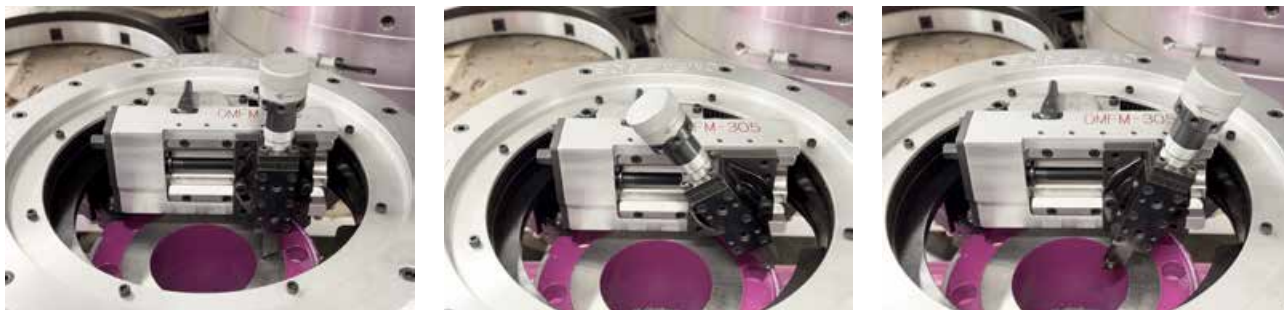

ELECTRIC DRIVE

As an option, we can deliver the electric motor, made by Makita. With 3 stage planetary gear box made by KRAIS, the drive has variable speed control and produce enormous torque. Is interchangeable with pneumatic drive and can be purchased separately at any time. Also available with battery driven motor!

Free Speed..... 115 RPM
 Power..... 750 W
 Torque..... 360 Nm (266 Ft.Lbs)



CONVENIENT JAWS



Special jaw set for easy and quick levelling and centring machine. A special mechanism allows convenient adjustment of the mounting plane relative to the pipe.

TIGHT SPACES

The OMFM-305 is also highly effective in hard-to-reach areas. It allows for the drive motor to be mounted on either side of the machine, making it ideal for machining flanges in confined spaces. Additionally, the optional angle module enables horizontal motor installation for even greater flexibility.



EFFICIENT ON-SITE OPERATION

The OMFM-305 is the ideal solution for professionals requiring a rugged and reliable machine for high-precision flange machining tasks. Its lightweight design, combined with heavy-duty construction and easy setup, makes it a versatile tool for a wide range of industrial applications.



IMFM-24/30

Internally mounted, lightweight, super rigid yet super heavy-duty machine tool. Ideal for machining all types of flange faces, seal grooves, weld preparations and counterbores.

- ▶ Heavy-duty steel/aluminium all design.
- ▶ Heavy-duty cast steel body and steel body plate.
- ▶ Solid construction and high rigidity of the machine concerning the dimension and weight.
- ▶ Continuous groove facing feed, 2-speed gearbox.
- ▶ Swivel tool post for grooves, RTJ flanges, and bevels.
- ▶ Quick-set independent bases for improved on-site operation.
- ▶ Fast mounted arm with spindle for the very convenient measure of levelling and centring.
- ▶ Super quick machine fixing to the locking base.
- ▶ Special jaw set for easy and quick levelling and centring machine; jaws are interchangeable with all IMFM series Flange Facers.
- ▶ CE certificate.



STANDARD WORKING RANGE		FACING FEEDS			FREE SPEED	POWER					
FACING RANGE	LOCKING RANGE	1,75 MM SCREW	1,25 MM SCREW	1,00 MM SCREW							
145 – 762 mm	140 - 670 mm	0,2 / 0,8 mm	0,14 / 0,57 mm	0,15 / 0,45 mm	20 - 42 Rpm	2,2 Hp					
5" - 30"	5-1/2" - 26"	0,008 / 0,031"	0,006 / 0,022"	0,004 / 0,018"		1,6 kW					
AIR USE		MACHINE WEIGHT		DRIVE WEIGHT		MAX BIG BASE WEIGHT	MAX SMALL BASE WEIGHT	COUNTER WEIGHT			
75 cfm	2,2 m ³ /min	26 kg	57,4 Lbs	5 kg	11,0 Lbs	18 kg	39,7 Lbs	4 kg	8,82 Lbs	6 kg	13,23 Lbs

	SHIPPING BOX		SHIPPING WEIGHT	
	75 x 55 x 35 cm	30" x 22" x 14"	80 kg	177 Lbs

TOOLING CHART

HOLDER	INSERT	SCREW	TORX
IMFM24-V11	CIV-11-3-1	MHS-4	TX-15

COMPLETE PACKAGE

As standard IMFM is supplied with the complete toolkit, including cutting tool and inserts and hose connection, required jaws to cover the full range, user manual and storage shipping box.

For IMFM, besides standard pneumatic 2,2 Hp drive, we offer a wide choice of pneumatic and electric drives.

UNIQUE RIGIDITY

High rigidity of the machine in relation to the dimension and weight by applying Heavy-duty cast steel body and steel body plate.



WIDE RANGE

Machine is equipped with 2 locking bases
Big 250-700 mm
Small 140 – 290 mm



IMFM-24/30

SWIVEL TOOL

Swivel tool post for grooves, RTJ flanges, and bevels



CONVENIENT JAWS

Special jaw set for easy and quick levelling and centring machine. A special mechanism allows convenient adjustment of the mounting plane relative to the pipe. Jaws are interchangeable with all IMFM series Flange Facers.



PRECISE MOUNTING



Fast mounted arm with spindle for the very convenient measure of levelling and cantering

FAST FIXING

Super fast machine fixing with locking base by means of a taper in the locking base and taper seat in the spindle fastened with a central locking screw

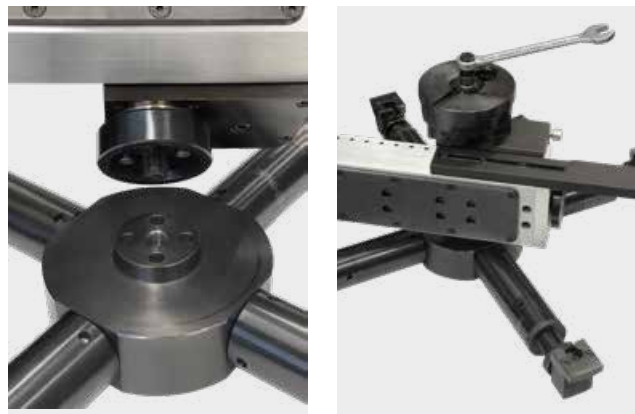

RIGHT ANGLE HEAD



This optional addon allows for fastening drive in alternate positions. The useful option in tight spaces.

ELECTRIC DRIVE

As an option, we can deliver the electric motor, made by Makita. With 3 stage planetary gear box made by KRAIS, the drive has variable speed control and produce enormous torque. Is interchangeable with pneumatic drive and can be purchased separately at any time. Also available with battery driven motor!

Free Speed..... 115 RPM
Power..... 750 W
Torque..... 360 Nm (266 Ft.Lbs)



IMFM-24 Internal Mounted Flange Mill

Internally mounted, lightweight and durable machine tool. Ideal for machining all types of flange faces, seal grooves, weld preparations and counterbores.

Features:

- ▶ Heavy-duty steel/aluminium design
- ▶ High rigidity of the machine in relation to the dimension and weight
- ▶ Solid but lightweight construction
- ▶ Continuous groove facing feeds
- ▶ Swivel tool post for grooves, RTJ flanges and bevels
- ▶ Easy levelling and centering system with built-in fast centre feature
- ▶ Quick clamping with solid, 50 mm self-centering steel shaft
- ▶ CE certificate

As standard IMFM is supplied with the complete toolkit, including cutting tool and inserts and hose connection, required jaws to cover the full range, paper manual and storage/shipping box. Beside standard pneumatic 2,2 Hp drive, for IMFM we offer a wide choice of pneumatic and electric drives.



STANDARD WORKING RANGE		FACING FEEDS			FREE SPEED	POWER	
FACING RANGE	LOCKING RANGE	1,75 MM SCREW	1,25 MM SCREW	1,00 MM SCREW			
100 – 610 mm	100 - 508 mm	0,2 / 0,8 mm	0,14 / 0,57 mm	0,15 / 0,45 mm	20 - 42 Rpm	2,2 Hp	
3,93 - 24,00"	3,93 - 20,00"	0,008 / 0,031"	0,006 / 0,022"	0,004 / 0,018"		1,6 kW	
AIR USE		BODY WIDTH		BODY HEIGHT		BODY WEIGHT	
75 cfm	2,2 m ³ /min	Depends on motor configuration, see drawing below		99 Lbs	45 kg		

LEVELLING & CENTERING



Special jaw set for easy and quick levelling and centering machines on the flange

TOOLING CHART

HOLDER	INSERT	SCREW	TORX
IMFM24-V11	CIV-11-3-1	MHS-4	TX-15

DIMENSIONS

INLINE VERSION

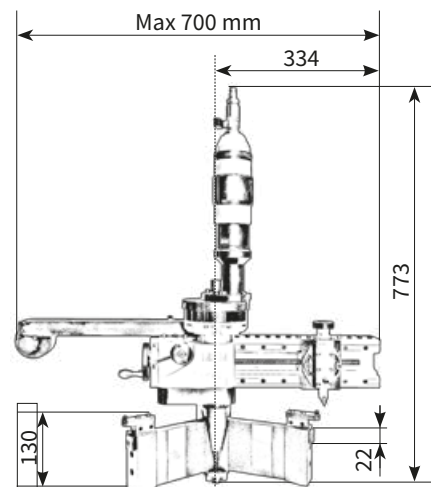

RIGHTANGLE VERSION

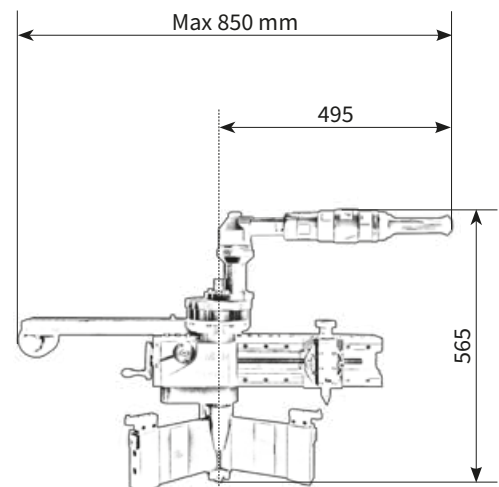

IMFM-40 Internal Mounted FlangeMill

Internally mounted, lightweight and durable machine tool. Ideal for machining all types of flange faces, seal grooves, weld preparations and counterbores.

- ▶ Heavy-duty steel/aluminium design with solid but lightweight construction
- ▶ High rigidity of the machine in relation to the dimension and weight
- ▶ Continuous groove facing feeds
- ▶ Swivel tool post for grooves, RTJ flanges and bevels
- ▶ Easy levelling and centering system with built-in self-centre feature
- ▶ Quick clamping with solid, 50 mm self-centering steel shaft
- ▶ CE certificate

As standard IMFM is supplied with the complete toolkit, including cutting tool and inserts and hose connection, required jaws to cover the full range, paper manual and storage/shipping box. Beside standard pneumatic 2,2 Hp drive, for IMFM we offer a wide choice of pneumatic and electric drives.



STANDARD WORKING RANGE		MAX SWING DIAMETER	TOOL POST TRAVEL	FEED RATES	FREE SPEED	POWER					
FACING RANGE	CLAMPING RANGE										
322 – 1016 mm	322 - 915 mm	1220 mm	102 mm	See table	0 - 24 Rpm	2,2 Hp					
12,67 - 40,00"	12,67 - 36,00"	48"	4"			1,6 kW					
AIR USE		SHIPPING WIDTH		SHIPPING HEIGHT		SHIPPING LENGTH		BODY WEIGHT		SHIPPING WEIGHT	
75 cfm	2,2 m ³ /min	600 mm	24"	725 mm	28,5"	845 mm	34"	145 kg	319 Lbs	210 kg	462 Lbs

FACING FEED RATES (3 OFF IN/OUT)

Direction	Gear	mm/rev	inch/rev	grooves per cm	grooves per inch
Out	1	0,139	0,005	72	183
	2	0,217	0,009	46	117
	3	0,528	0,021	19	48
In	1	0,165	0,006	61	154
	2	0,258	0,010	39	98
	3	0,628	0,025	16	40

BORING FEED RATES (3 OFF UP/DOWN)

mm/rev	inches/rev
0.05 – 0.10 – 0.20	0.002 – 0.004 – 0.008

TOOLING CHART

HOLDER	INSERT	SCREW	TORX
IMFM40F-V11	CIV-11-3-1	MHS-4	TX-15
IMFM40P-V11	CIV-11-3-1	MHS-4	TX-15
IMFM40L-V11	CIV-11-3-1	MHS-4	TX-15

MACHINE IN ACTION



IMFM-40 and IMFM-60 features

LEVELLING AND CENTERING

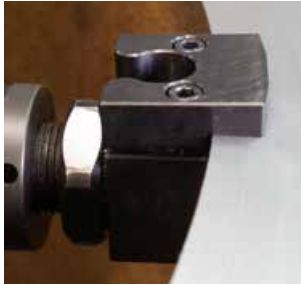

Both machines are equipped with special jaw set for easy, quick levelling and centering. A special mechanism allows convenient adjustment of the mounting plane relative to the pipe. Built-in self-centering locking system significantly facilitates the coarse setting of the machine.

ELECTRIC DRIVE



As an alternative, we offer an electric drive for IMFM40&60. The motor provides similar parameters to the pneumatic one.

SWIVEL TOOL AS A STANDARD



Standard configuration of IMFM is equipped with swivel tool post for grooves, RTJ flanges and bevels

TWO LOCKING PLATES



The offer includes two sizes of locking system. Thanks to the matching dimensions of the rigid body, stable mounting and smooth machining of face surfaces and flanges in all pipe sizes is possible.

IMFM-60 Internal Mounted FlangeMill

Internally mounted, lightweight and durable machine tool. Ideal for machining all types of flange faces, seal grooves, weld preparations and counterbores.

- ▶ Heavy-duty steel/aluminium design with solid but lightweight construction
- ▶ High rigidity of the machine in relation to the dimension and weight
- ▶ Continuous groove facing feeds
- ▶ Swivel tool post for grooves, RTJ flanges and bevels
- ▶ Easy levelling and centering system with built-in self-centre feature
- ▶ Quick clamping with solid, 50 mm self-centering steel shaft
- ▶ CE certificate

As standard IMFM is supplied with the complete toolkit, including cutting tool and inserts and hose connection, required jaws to cover the full range, paper manual and storage/shipping box. Beside pneumatic 4,0 Hp drive, for IMFM we offer a wide choice of pneumatic and electric drives.



STANDARD WORKING RANGE		MAX SWING DIAMETER	TOOL POST TRAVEL	FEED RATES	FREE SPEED	POWER					
FACING RANGE	CLAMPING RANGE										
507 – 1525 mm	507 - 1400 mm	1745 mm	102 mm	See table	0 - 22 Rpm	4,0 Hp					
20" - 60"	20" - 55"	68"	4"			3,0 kW					
AIR USE		SHIPPING WIDTH		SHIPPING HEIGHT		SHIPPING LENGTH		BODY WEIGHT		SHIPPING WEIGHT	
98 cfm	2,69 m ³ /min	820 mm	32"	830 mm	33"	1230 mm	48"	412 kg	906 Lbs	499 kg	1010 Lbs

FACING FEED RATES (3 OFF IN/OUT)

Direction	Gear	mm/rev	inch/rev	grooves per cm	grooves per inch
Out	1	0,130	0,005	76	195
	2	0,203	0,008	49	125
	3	0,494	0,019	20	51
In	1	0,155	0,006	65	164
	2	0,241	0,009	41	105
	3	0,588	0,023	17	43

BORING FEED RATES (3 OFF UP/DOWN)

mm/rev	inches/rev
0.05 – 0.10 – 0.20	0.002 – 0.004 – 0.008

TOOLING CHART

HOLDER	INSERT	SCREW	TORX
IMFM60F-V11	CIV-11-3-1	MHS-4	TX-15
IMFM60P-V11	CIV-11-3-1	MHS-4	TX-15
IMFM60L-V11	CIV-11-3-1	MHS-4	TX-15

MACHINE FACING 60" FLANGE RING



SFFM Flange Facer

SFFM series Flange Facing Machines are mounted on the outer diameter of the flange. The precise, synchronized radial and axial feed mechanism allows for a high quality machining, resulting in one continuous groove producing a true gramophone finish.

SFFM Flange Facing Machines are suitable for various flange types:

- ▶ Flat Face
- ▶ Raised Face
- ▶ Ring Type Joints (RTJ)
- ▶ Tongue & Groove
- ▶ Lens Ring
- ▶ Grayloc® (hub profile)
- ▶ Compact Flanges

SFFM Flange Facers are suitable for the oil and gas industry, power plants, chemical plants, oil rigs and many others. They are prepared to implement applications complying with ASME standards.



MODEL	WORKING RANGE			DIMENSIONS					WEIGHT	JAWS
	UNIT	MIN OD	MAX OD	UNIT	FRAME OD	FRAME ID	FRAME WIDTH	HEIGHT		
SFFM-0410	NPS	2,00	10,00	[inch]	16,22	11,24	2,50	17,3"	57	4
	Metric	50,00	250,00	[mm]	412,00	285,40	63,50	440		
SFFM-1016	NPS	2,00	15,00	[inch]	21,46	16,48	2,50	17,3"	68	6
	Metric	50,00	370,00	[mm]	545,00	418,70	63,50	440		
SFFM-1624	NPS	4,00	23,00	[inch]	29,49	24,41	2,50	17,3"	103	10
	Metric	100,00	580,00	[mm]	749,00	619,90	63,50	440		
SFFM-2836	NPS	8,00	35,00	[inch]	42,15	37,00	2,76	17,3"	180	10
	Metric	200,00	890,00	[mm]	1070,60	939,80	65,40	440		
SFFM-4048	NPS	10,00	47,00	[inch]	54,40	49,53	2,76	17,3"	260	12
	Metric	250,00	1200,00	[mm]	1381,80	1251,00	65,40	440		

FEATURES OF MACHINE

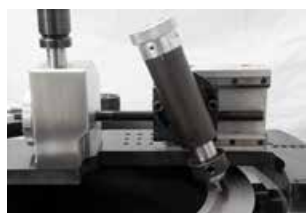

CUTTING GROOVES

The machine offers a simple way of execution of the RTJ grooves by using the single point swivel head or formed tools



GRAMOPHONE GROOVE

The design of the feed attachment assures the automatic and variable feed rate on radial axe producing proper gramophone groove.



STRONG DRIVES

Machine can be driven with a wide range of motors, pneumatic, hydraulic and electrical, including servo drives - all made by KRAIS.



AVAILABLE AS MODULE

For owners of our regular SFSF machines we offer special module, allowing to convert the standard SFSF into regular flange facing module

TOOLING CHART

HOLDER	INSERT	SCREW	TORX
SFFM-V11	CIV-11-3-1	MHS-4	TX-15

SFFM Module

SFFM Module can be mounted on all our SFSF clamshells and convert the regular Clamshell into OD mount flange facing machine. SFSF clamshell combined with the module widens the scope of its application and still providing the same functionality as the machine SFFM.

Purchasing the SFFM Module allows to save a lot of money by avoiding the purchase of two separate machine tools.

Time needed for the machine changeover is only 20 minutes.



SFSF MODEL	WORKING RANGE WITH MODULE			DIMMENSIONS					WEIGHT*	JAWS
	UNIT	MIN OD	MAX OD	UNIT.	FRAME OD	FRAME ID	FRAME WIDTH	BOTH HEIGHT		
SFSF-0410	NPS	0,80	8,80	[inch]	16,22	11,24	2,50	16,25	57,00	4
	Metric	20,00	224,00	[mm]	412,00	285,40	63,50	412,5		
SFSF-0612	NPS	1,60	10,50	[inch]	18,15	13,24	2,50	16,25	59,00	4
	Metric	40,00	270,00	[mm]	461,00	336,20	63,50	412,5		
SFSF-0814	NPS	1,60	12,00	[inch]	19,49	14,48	2,50	16,25	61,00	6
	Metric	40,00	305,00	[mm]	495,00	367,90	63,50	412,5		
SFSF-1016	NPS	1,60	14,00	[inch]	21,46	16,48	2,50	16,29	68,00	6
	Metric	40,00	356,00	[mm]	545,00	418,70	63,50	413,5		
SFSF-1218	NPS	2,00	16,80	[inch]	23,50	18,48	2,50	16,29	83,00	6
	Metric	50,00	427,00	[mm]	597,00	469,50	63,50	413,5		
SFSF-1420	NPS	2,00	20,00	[inch]	25,47	20,85	2,50	16,29	90,00	6
	Metric	50,00	508,00	[mm]	647,00	520,30	63,50	413,5		
SFSF-1624	NPS	2,00	22,70	[inch]	29,49	24,41	2,50	16,29	103,00	10
	Metric	50,00	578,00	[mm]	749,00	619,90	63,50	413,5		
SFSF-2028	NPS	4,00	26,80	[inch]	33,90	28,75	2,76	17,48	145,00	10
	Metric	100,00	681,00	[mm]	861,10	730,30	65,40	443,7		
SFSF-2432	NPS	8,00	30,70	[inch]	38,15	33,00	2,76	17,48	158,00	10
	Metric	200,00	782,00	[mm]	969,00	838,20	65,40	443,7		
SFSF-2836	NPS	8,00	34,80	[inch]	42,15	37,00	2,76	17,48	180,00	10
	Metric	200,00	884,00	[mm]	1070,60	939,80	65,40	443,7		
SFSF-3442	NPS	10,00	40,70	[inch]	48,15	43,00	2,76	17,48	202,00	10
	Metric	250,00	1036,00	[mm]	1223,00	1092,20	65,40	443,7		
SFSF-4048	NPS	10,00	46,80	[inch]	54,40	49,53	2,76	17,48	260,00	12
	Metric	250,00	1189,00	[mm]	1381,80	1251,00	65,40	443,7		

*depends on machine configuration

SURFACE FINISH



The Modul is equipped as standard with feed gearbox in order to generate both, fine or coarse surface finish by simple switch on the gear box.

TOOLING CHART

HOLDER	INSERT	SCREW	TORX
SFFM-V11	CIV-11-3-1	MHS-4	TX-15

MicroDrill-SOFD

Studding outlet flange drilling tool

MicroDrill-SOFD machine is specifically designed for this problem. It can fit even on 1" studding outlet flanges and, with its low-speed, high-torque operation, can drill holes up to 20 mm, making it perfect for precise drilling in tight spaces.

The locking shafts are 150 mm long as standard and 300 mm as optional. Other lengths are available on request.

Studding Outlet Flanges, also known as "pad flanges" (ANSI B16.5 ASTM A182), are often installed inside or outside vessels and tanks. A common issue arises when a stud breaks or shears, requiring the flange to be drilled out and re-threaded.



KEY FEATURES

UP TO 20 MM (2.4") DRILLING

Covers most heat exchanger tube sheets; suitable for various equipment types.

COMPACT BODY

Machine is lightweight and can be used in very tight spaces.

TORQUE-REACTIVE PLATFORM

Firm clamping absorbs machining forces, improving safety and control.

OPERATOR SAFETY

Designed for quick, safe plug removal with minimal risk.

WORKING RANGE		LOCKING RANGE		POWER		TORQUE	
12,5– 38,0 mm		According to the drawing		0,98 Hp		18 Nm / 300 RPM (55 Nm / 100 RPM*)	
0,492 – 1,496"						13,28 Ft-lbs / 300 RPM (40,57 Ft-lbs / 100 RPM*)	
AIR USE		BODY WIDTH		BODY HEIGHT		BODY LENGTH	
17 cfm	0,48 m ³ /min	1,73"	44 mm	10,82"	275 mm	12,2"	310 mm

*with 3x Speed Reducer

STABILITY AND DURABILITY



MiniDrill-SOFD features a robust steel frame for stability and durability. Precision locking plates ensure perfect centering on any flange size for stud drilling and thread prep. It also handles oversized holes with ease.

STANDARD TOOL



The machine is equipped with a standard ER25 collet chuck with the Weldon-type holder for quick and efficient tool changes. If needed, other configurations can be provided upon request to suit specific applications.

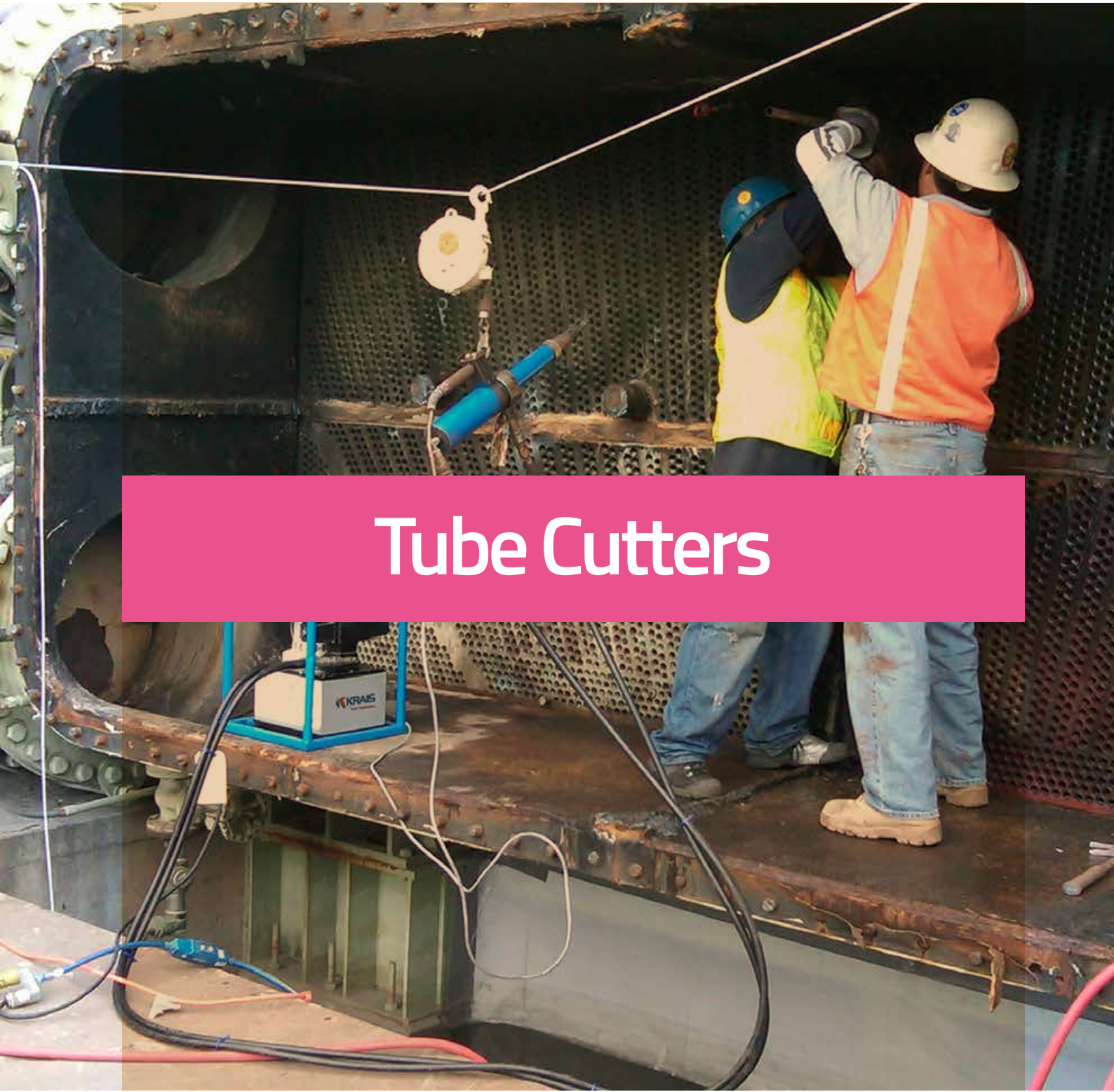

Tube Cutters

MiniCut Tools

MiniCut 100 for heat exchangers

MiniCut 100 is recommended for use in cutting alloy and ferrous tubing up to 1-1/4" O.D. Heavy wall tubing up to 10 BWG can be cut quickly and efficiently. Tool uses one cutting bit to cut any material tubes. The MiniCut 100 tool is equipped with star wheel feed for smooth, positive power transmission to the cutting bit.

Tool is available as electric version. MiniCut 100E covers the same tube sizes and comes with the same cutting head.



MiniCut 300 for condenser and chillers

The MiniCut 300 is recommended for use in cutting tubes within condensers, chillers and similar vessels with non-ferrous tubes. Tool uses one cutting bit, can cut 1" x 16 BWG brass tubes in just a few seconds. This machine is equipped with lever feed handle as standard. Tool is available as electric version. MiniCut 300E covers the same tube sizes and comes with the same cutting head.



CUTTING RANGE		POWER		FREE SPEED		TORQUE	
Up to 1-1/4" OD		1,3 Hp		100 Rpm		105 Ft.Lbs	
Up to 31,7 mm						140 Nm	
AIR USE		WIDTH		HEIGHT		WEIGHT	
55 cfm	1,3 m³/min	2,32"	59 mm	13,1"	335 mm	9 Lbs	4,5 kg

CUTTING RANGE		POWER		FREE SPEED		TORQUE	
Up to 1" OD		1,3 Hp		300 Rpm		18 Ft.Lbs	
Up to 25,4 mm						24 Nm	
AIR USE		WIDTH		HEIGHT		WEIGHT	
55 cfm	1,3 m³/min	2,32"	59 mm	13,1"	335 mm	9 Lbs	4,5 kg

MINICUT 100 E

Tool is driven by electric motor made by Makita with 3 stage planetary gear box made by KRAIS and has variable speed control. Is interchangeable with pneumatic drive and can be purchased separately at any time.

Free Speed.....120 RPM
 Power.....750 W
 Torque.....360 Nm (266 Ft.Lbs)
 Feed Stroke25 mm (1")



MINICUT 300 E

Tool is driven by electric motor made by Makita with 3 stage planetary gear box made by KRAIS and has variable speed control. Is interchangeable with pneumatic drive and can be purchased separately at any time.

Free Speed.....300 RPM
 Power.....750 W
 Torque.....122 Nm (92 Ft.Lbs)
 Feed Stroke25 mm (1")



MiniCut Tools

MiniCut 101/AF with automatic feed

MiniCut 101/AF tube cutting machine with Automatic Feed. Alloy and ferrous tubes up to 1-1/4" with heavy wall up to 10 BWG can be cut quickly, consistently efficiently and effortlessly within 15-40 second depending on diameter and wall thickness. The MiniCut 101/AF tool is equipped with pneumatic/hydraulic automatic feed for positive power transmission to the cutting bit.



CUTTING RANGE		POWER	FREE SPEED	TORQUE	
Up to 1-1/4" OD		1,3 Hp	100 Rpm	105 Ft.Lbs	
Up to 31,7 mm				140 Nm	
AIR USE		DIMENSIONS		WEIGHT	
55 cfm	1,3 m³/min	2,44" x 14,96" x 21,25"		62 x 380 x 540 mm	25,35 Lbs, 11,5 kg

MINICUT 101/AF-RB OPTION



The most convenient version can be delivered with reaction bar with two locking shafts. The reaction bar is universal and allows to precise tool alignment to the tubes pitch. Dim: 250 x 330 x 54 mm / 9,84 x 14,96 x 21,25" Weight: 13,5 kg / 29,76 Lbs



Tube Cutters for MiniCut Machines

Tools are available in 3" standard length, other upon order: 6" and 14"



TUBE OD		TUBE GAUGE	TUBE ID	TOOL NO.	CUTTER BIT NO.	BODY DIAMETER	NUMBER OF BLADES
[INCH]	[MM]	[BWG]					
5/8	15,8	12-13	10,3 - 10,05	PTMC-158-3"-12	K-25186	10,00	1
5/8	15,8	14-15	11,66 - 12,22	PTMC-158-3"-14	K-25186	11,30	1
5/8	15,8	16-17	12,57 - 12,93	PTMC-158-3"-16	K-25186	12,20	1
5/8	15,8	18-19	13,40 - 13,74	PTMC-158-3"-18	K-25186	13,10	1
5/8	15,8	20-22	14,10 - 14,45	PTMC-158-3"-20	K-25186	13,80	1
3/4	19,0	14-15	14,80 - 15,40	PTMC-190-3"-14	K-25186	14,50	1
3/4	19,0	16-17	15,75 - 16,10	PTMC-190-3"-16	K-25186	15,40	1
3/4	19,0	18-19	16,56 - 16,90	PTMC-190-3"-18	K-25186	16,15	1
3/4	19,0	20-22	17,27 - 17,63	PTMC-190-3"-20	K-25186	17,00	1
7/8	22,2	10-11	15,42 - 16,13	PTMC-222-3"-10	K-25194	15,00	1
7/8	22,2	12-13	16,69 - 17,40	PTMC-222-3"-12	K-25194	16,20	1
7/8	22,2	14-15	18,01 - 18,57	PTMC-222-3"-14	K-25194	17,60	1
7/8	22,2	16-17	18,92 - 19,28	PTMC-222-3"-16	K-25194	18,50	1
7/8	22,2	18-20	19,74 - 20,42	PTMC-222-3"-18	K-25194	19,40	1
1	25,4	8-9	17,02 - 17,88	PTMC-254-3"-8	K-25199	16,60	1
1	25,4	10-11	18,59 - 19,30	PTMC-254-3"-10	K-25199	18,20	1
1	25,4	12-13	19,86 - 20,57	PTMC-254-3"-12	K-25199	19,40	1

TUBE OD		TUBE GAUGE	TUBE ID	TOOL NO.	CUTTER BIT NO.	BODY DIAMETER	NUMBER OF BLADES
[INCH]	[MM]	[BWG]					
1	25,4	14-15	21,18 - 21,74	PTMC-254-3"-14	K-25199	20,80	1
1	25,4	16-17	22,10 - 22,45	PTMC-254-3"-16	K-25199	21,70	1
1	25,4	18-19	22,91 - 23,27	PTMC-254-3"-18	K-25199	22,50	1
1	25,4	20-22	23,62 - 23,89	PTMC-254-3"-20	K-25199	23,20	1
1-1/8	28,5	13-14	23,75 - 24,36	PTMC-285-3"-13	K-25199	23,40	1
1-1/8	28,5	15-16	24,92 - 25,27	PTMC-285-3"-14	K-25199	24,50	1
1-1/8	28,5	17-18	25,63 - 26,09	PTMC-285-3"-17	K-25199	25,10	1
1-1/4	31,7	12-13	26,21 - 26,92	PTMC-317-3"-12	K-25206	25,80	1
1-1/4	31,7	14-15	27,53 - 28,09	PTMC-317-3"-14	K-25206	27,10	1
1-1/4	31,7	16-17	28,45 - 28,80	PTMC-317-3"-16	K-25206	28,00	1
1-1/4	31,7	18-20	29,26 - 29,92	PTMC-317-3"-20	K-25206	28,80	1
1-1/2	38,1	8-9	29,72 - 30,58	PTMC-381-3"-8	K-25206	29,30	1
1-1/2	38,1	10-11	31,29 - 32,00	PTMC-381-3"-10	K-25206	30,08	1
1-1/2	38,1	12-13	32,56 - 33,27	PTMC-381-3"-12	K-25206	32,10	1
1-1/2	38,1	14-15	33,88 - 34,44	PTMC-381-3"-14	K-25206	33,40	1
1-1/2	38,1	16-17	34,80 - 35,15	PTMC-381-3"-16	K-25206	34,40	1
1-1/2	38,1	18-20	35,51 - 36,32	PTMC-381-3"-18	K-25206	35,10	1

HyperCut

HyperCut: Internal Boiler Tube Cutter

The HyperCut is a heavy-duty **internal tube cutter** specifically engineered for larger-diameter tubes in the boilers and related industrial pressure vessels. Featuring a robust and **field-proven design**, this tool is built to withstand the rigors of intensive maintenance environments. The system utilizes a standard single-blade cutting configuration that enables the severance of thick-walled tubes in a matter of minutes, significantly reducing downtime during retubing operations. Driven by a high-torque 1.35 HP motor, the HyperCut delivers the necessary **power and stability** to ensure clean, precise cuts through heavy-gauge materials with ease.



CUTTING RANGE		POWER	FREE SPEED		TORQUE		
44,5 to 101,6 mm		1,35 Hp	55 Rpm		210 Ft.Lbs		
1-3/4" to 4"					280 Nm		
AIR USE		BODY WIDTH		BODY HEIGHT		BODY WEIGHT	
55 cfm	1,3 m³/min	3,22"	82 mm	15"	385 mm	19 Lbs	9 kg

OPTIONAL SPEED REDUCER



Easy to use gearbox for 3x speed reduction. Increases the torque, enabling the machine to cut heavy wall tubes.

AVAILABLE CUTTERS FOR HYPERCUT

TUBE OD		WALL RANGE	TUBE ID				TOOL NO.	CUTTER BIT NO.	NUMBER OF CUTTER BITS	PILOTS
[INCH]	[MM]		[MM]		[INCH]					
		BWG	MIN	MAX	MIN	MAX				
1-3/4"	44,5	8-16	36,07	41,15	1,42	1,62	PTHC-444-U-6"	K-25221	1	4 PCS
2"	50,8	8-16	42,42	47,50	1,67	1,87	PTHC-508-U-6"	K-25221	1	4 PCS
2-1/8"	54,0	8-16	45,59	50,67	1,79	1,99	PTHC-542-U-6"	K-25221	1	4 PCS
2-1/4"	57,2	8-16	48,77	53,85	1,92	2,12	PTHC-572-U-6"	K-25221	1	4 PCS
2-3/8"	60,3	8-16	51,94	57,02	2,04	2,24	PTHC-603-U-6"	K-25223	1	4 PCS
2-1/2"	63,5	8-16	55,12	60,20	2,17	2,37	PTHC-635-U-6"	K-25223	1	4 PCS
2-3/4"	69,9	8-16	61,47	66,55	2,42	2,62	PTHC-698-U-6"	K-25223	1	4 PCS
3"	76,2	8-16	67,82	72,90	2,67	2,87	PTHC-762-U-6"	K-25762	1	4 PCS
3-1/4"	82,6	8-16	74,17	79,25	2,92	3,12	PTHC-825-U-6"	K-25820	1	4 PCS
3-1/2"	88,9	8-16	80,52	85,60	3,17	3,37	PTHC-889-U-6"	K-25820	1	4 PCS
4"	101,6	8-16	93,22	98,30	3,67	3,87	PTHC-1016-U-6"	K-25900	1	4 PCS

OPTIONAL TWO BLADES CUTTER



Optional two-blade cutters may be used in specific applications.

HYPERCUT ELECTRIC

HyperCut can be driven by electric motor. The machine can cover the same pipe sizes and comes with the same cutting head. The electric motor made by Makita with 3 stage planetary gear box made by KRAIS has variable speed control and produce enormous torque. Is interchangeable with pneumatic drive and can be purchased separately at any time.



BATTERY OPTION

The machine is also available with a portable electric drive 18 Volt 5.2 Ah 93.6 Wh Li-Ion battery. The machine can operate up to half hour on one battery. It is possible to have many charged batteries. Comfortable and easy to use in any place where compressed air and electricity is not available or even impossible to use as for example oil refinery.



KDM Pneumatic drill

KRAIS KDM is high torque, pneumatic, low-speed drilling machine for any application. Recommended for use with KRAIS PTTC Tube Cutters, PTTT Tube Trimmers, TEF Tube End Facers and JGS Grooving Tools.

MODEL	RPM	TORQUE		POWER	AIR USE		WEIGHT	
		NM	FT/LBS	HP	CFM	L/MIN	KG	LBS
70-KDM	70	188	138	1,3	48	1200	6,5	14,3
130-KDM	130	105	78	1,3	48	1200	6,5	14,3
180-KDM	180	79	58	1,3	48	1200	6,5	14,3
400-KDM	400	36	27	1,3	48	1200	6,5	14,3

KDM Pneumatic Drill can be used as a portable drive for many typical tube works. In connection with proper tools offers a wide range of uses.



PTTC Universal



This tools are used with KDM Pneumatic drill

TUBE OD		TUBE GAUGE	TOOL NO.	CUTTER BIT NO.	NUMBER OF BLADES	DRIVE SHANK
[INCH]	[MM]	[BWG]				
5/8	15,8	16-22	PTTC-U-158	K-25186	1	HEX-1/2"
3/4	19	14-22	PTTC-U-190	K-25186	1	HEX-1/2"
7/8	22,2	11-22	PTTC-U-222	K-25194	1	HEX-1/2"
1	25,4	11-13	PTTC-U-222	K-25194	1	HEX-1/2"
		14-22	PTTC-U-254	K-25199	2	HEX-1/2"
1-1/4	31,7	14-22	PTTC-U-317	K-25206	2	HEX-5/8"
1-1/2	38,1	10-20	PTTC-U-381	K-25206	2	HEX-5/8"
2	50,8	8-20	PTTC-U-508	K-25221	2	SQ-3/4"
2-1/2	63,5	8-12	PTTC-U-635	K-25223	2	SQ-3/4"

PTTT - Tube trimmer



This tools are used with KDM Pneumatic drill

TUBE OD		TUBE GAUGE	TOOL NO.	CUTTER BIT NO.	NUMBER OF BLADES	DRIVE SHANK
[INCH]	[MM]	[BWG]				
5/8	15,8	16-22	PTTT-158	K-25186	1	HEX-1/2"
3/4	19	14-22	PTTT-190	K-25186	1	HEX-1/2"
7/8	22,2	11-22	PTTT-222	K-25194	1	HEX-1/2"
1	25,4	11-13	PTTT-222	K-25194	1	HEX-1/2"
		14-22	PTTT-254	K-25199	2	HEX-1/2"
1-1/4	31,7	14-22	PTTT-317	K-25206	2	HEX-5/8"
1-1/2	38,1	10-20	PTTT-381	K-25206	2	HEX-5/8"
2	50,8	8-20	PTTT-508	K-25221	2	SQ-3/4"
2-1/2	63,5	8-12	PTTT-635	K-25223	2	SQ-3/4"

Solid body PTTC

The PTTC cutter blade depth can be adjusted to cut through the tube. The tool uses one or two HSS blades. The front pilot under the cutter keeps it centered and prevents jams, as chips move forward into the tube. Also available as a tube trimmer and push-type trimmer.



This tools are used with KDM Pneumatic drill

TUBE OD		TUBE GAUGE	TUBE ID [MM]		TUBE ID [INCH]		CUTTER BODY DIAMETER	TOOL NO.	CUTTER BIT NO.	NUMBER OF BLADES	DRIVE SHANK
[INCH]	[MM]	[BWG]	MIN	MAX	MIN	MAX					
3/8"	9,5	22-24	8,10	8,40	0,319	0,331	7,8	PTTC-95-3"-22	K-25210-78	1	HEX-1/2"
1/2"	12,7	14-15	8,50	9,04	0,335	0,356	8,2	PTTC-127-3"-14	K-25210	1	HEX-1/2"
		16-17	9,40	9,75	0,370	0,384	9,2	PTTC-127-3"-16	K-25210	1	HEX-1/2"
5/8"	15,8	12-13	10,30	10,05	0,406	0,396	10	PTTC-158-3"-12	K-25186-A	1	HEX-1/2"
		14-15	11,66	12,22	0,459	0,481	11,3	PTTC-158-3"-14	K-25186-B	1	HEX-1/2"
		16-17	12,57	12,93	0,495	0,509	12,2	PTTC-158-3"-16	K-25186-B	1	HEX-1/2"
		18-19	13,40	13,74	0,528	0,541	13,1	PTTC-158-3"-18	K-25186	1	HEX-1/2"
		20-22	14,10	14,45	0,555	0,569	13,8	PTTC-158-3"-20	K-25186	1	HEX-1/2"
3/4"	19	14-15	14,80	15,40	0,583	0,606	14,5	PTTC-190-3"-14	K-25186	1	HEX-1/2"
		16-17	15,75	16,10	0,620	0,634	15,4	PTTC-190-3"-16	K-25186	1	HEX-1/2"
		18-19	16,56	16,90	0,652	0,665	16,15	PTTC-190-3"-18	K-25186	1	HEX-1/2"
		20-22	17,27	17,63	0,680	0,694	17	PTTC-190-3"-20	K-25186	1	HEX-1/2"
7/8"	22,2	10-11	15,42	16,13	0,607	0,635	15	PTTC-222-3"-10	K-25194	1	HEX-1/2"
		12-13	16,69	17,40	0,657	0,685	16,2	PTTC-222-3"-12	K-25194	1	HEX-1/2"
		14-15	18,01	18,57	0,709	0,731	17,6	PTTC-222-3"-14	K-25194	1	HEX-1/2"
		16-17	18,92	19,28	0,745	0,759	18,5	PTTC-222-3"-16	K-25194	1	HEX-1/2"
1"	25,4	18-20	19,74	20,42	0,777	0,804	19,4	PTTC-222-3"-18	K-25194	1	HEX-1/2"
		8-9	17,02	17,88	0,670	0,704	16,6	PTTC-254-3"-8	K-25199-A	1	HEX-1/2"
		10-11	18,59	19,30	0,732	0,760	18,2	PTTC-254-3"-10	K-25199-B	1	HEX-1/2"
		12-13	19,86	20,57	0,782	0,810	19,4	PTTC-254-3"-12	K-25199-B	1	HEX-1/2"
		14-15	21,18	21,74	0,834	0,856	20,8	PTTC-254-3"-14	K-25199	1	HEX-1/2"
1-1/8"	28,5	16-17	22,10	22,45	0,870	0,884	21,7	PTTC-254-3"-16	K-25199	1	HEX-1/2"
		18-19	22,91	23,27	0,902	0,916	22,5	PTTC-254-3"-18	K-25199	1	HEX-1/2"
		20-22	23,62	23,89	0,930	0,941	23,2	PTTC-254-3"-20	K-25199	1	HEX-1/2"
		13-14	23,75	24,36	0,935	0,959	23,4	PTTC-285-3"-13	K-25199	1	HEX-5/8"
		15-16	24,92	25,27	0,981	0,995	24,5	PTTC-285-3"-14	K-25199	1	HEX-5/8"
1-1/4"	31,7	17-18	25,63	26,09	1,009	1,027	25,1	PTTC-285-3"-17	K-25199	1	HEX-5/8"
		12-13	26,21	26,92	1,032	1,060	25,8	PTTC-317-3"-12	K-25206	1	HEX-5/8"
		14-15	27,53	28,09	1,084	1,106	27,1	PTTC-317-3"-14	K-25206	1	HEX-5/8"
		16-17	28,45	28,80	1,120	1,134	28	PTTC-317-3"-16	K-25206	1	HEX-5/8"
1-1/2"	38,1	18-20	29,26	29,92	1,152	1,178	28,8	PTTC-317-3"-20	K-25206	1	HEX-5/8"
		8-9	29,72	30,58	1,170	1,204	29,3	PTTC-381-3"-8	K-25206	1	HEX-5/8"
		10-11	31,29	32,00	1,232	1,260	30,08	PTTC-381-3"-10	K-25206	1	HEX-5/8"
		12-13	32,56	33,27	1,282	1,310	32,1	PTTC-381-3"-12	K-25206	1	HEX-5/8"
		14-15	33,88	34,44	1,334	1,356	33,4	PTTC-381-3"-14	K-25206	1	HEX-5/8"
2"	50,8	16-17	34,80	35,15	1,370	1,384	34,4	PTTC-381-3"-16	K-25206	1	HEX-5/8"
		18-20	35,51	36,32	1,398	1,430	35,1	PTTC-381-3"-18	K-25206	1	HEX-5/8"
		8	42,42			1,670	42	PTTC-508-3"-8	K-25221	1	SQ-3/4"
		9	43,28			1,704	42,8	PTTC-508-3"-9	K-25221	1	SQ-3/4"
		10	44,00			1,732	43,6	PTTC-508-3"-10	K-25221	1	SQ-3/4"
		11	44,70			1,760	44,3	PTTC-508-3"-11	K-25221	1	SQ-3/4"
		12	45,26			1,782	44,8	PTTC-508-3"-12	K-25221	1	SQ-3/4"
		13	46,00			1,811	45,6	PTTC-508-3"-13	K-25221	1	SQ-3/4"
2-1/2"	63,5	14	46,60			1,835	46,2	PTTC-508-3"-14	K-25221	1	SQ-3/4"
		15	47,14			1,856	46,7	PTTC-508-3"-15	K-25221	1	SQ-3/4"
		16-20	47,50	48,94	1,870	1,927	47,1	PTTC-508-3"-16	K-25221	1	SQ-3/4"
		8	55,12			2,170	54,7	PTTC-635-3"-8	K-25223	1	SQ-3/4"
		9	55,98			2,204	55,6	PTTC-635-3"-9	K-25223	1	SQ-3/4"
10	56,70			2,232	56,3	PTTC-635-3"-10	K-25223	1	SQ-3/4"		
11	57,40			2,260	57	PTTC-635-3"-11	K-25223	1	SQ-3/4"		
12	57,96			2,282	57,5	PTTC-635-3"-12	K-25223	1	SQ-3/4"		

ORTC - One Revolution Tube Cutter

Tools designed for cutting both ferrous and non-ferrous tubes commonly found in heat exchangers, boilers and condensers. Standard tool length is adjustable from 1"-6" (25-155 mm). Longer reach tools are available in 10" (254 mm) increments. The tool is designed to be used with a hand or ratchet wrench only. Impact wrenches should never be used with these tools. The Cutting of the tube is based on the eccentric principle, where the cutter bit moves out to the tube wall as the cutter is rotated. Continued clockwise rotation will puncture and cut the tube in one revolution. Simply rotating the tool counterclockwise closes the bit and the tool can be removed from the tube.



ORTCC - ONE REVOLUTION TUBE CUTTER VERSION C

One Revolution Tube Cutter version C is used for piercing heavy wall, carbon steel tubes for ventilation prior to plugging the leaky tubes. Delivered in two length version 6" and 12".

TUBE OD		TUBE GAUGE	TUBE ID				TOOL NO.	TOOL BIT	
[INCH]	[MM]		[MM]		[INCH]				
1/2	12,70	18-19	10,20	10,70	0,402	0,421	ORTCC-100	N-625-4	
		20	11,00	11,30	0,433	0,445	ORTCC-108	N-625-4	
5/8	15,88	14	11,40	11,90	0,449	0,469	ORTCC-113	N-625-3	
		15-16	12,00	12,90	0,472	0,508	ORTCC-119	N-625-3	
		17-18	12,70	13,50	0,500	0,531	ORTCC-123	N-625-2	
		19-20	13,50	14,20	0,531	0,559	ORTCC-131	N-625-2	
3/4	19,05	22	14,00	14,70	0,551	0,579	ORTCC-139	N-750-2	
		14-15	14,70	15,50	0,579	0,610	ORTCC-145	N-750-2	
		16-18	15,20	16,50	0,598	0,650	ORTCC-153	N-750-2	
7/8	22,23	19-20	16,70	17,50	0,657	0,689	ORTCC-163	N-1000-1	
		14-15	17,80	18,50	0,701	0,728	ORTCC-174	N-1000-1	
		16-17	18,80	19,50	0,740	0,768	ORTCC-184	N-1000-1	
		18-20	19,30	20,60	0,760	0,811	ORTCC-193	N-1000-2	
1	25,40	12	19,80	20,60	0,780	0,811	ORTCC-193	N-1000-2	
		14	20,80	21,60	0,819	0,850	ORTCC-205	N-1000-2	
1	25,40	15	21,30	22,10	0,839	0,870	ORTC-210	N-1000-2	
		16-17	21,80	22,60	0,858	0,890	ORTC-215	N-1000-2	
		18-20	22,60	23,10	0,890	0,909	ORTC-223	N-1000-2	
		22	23,90	24,60	0,941	0,969	ORTC-232	N-1000-2	
1-1/4	31,75	10-11	24,90	25,60	0,980	1,008	ORTC-245	N-1000-2	
		12	25,90	26,70	1,020	1,051	ORTC-255	N-1000-2	
		13-14	26,70	27,40	1,051	1,079	ORTC-264	N-1000-2	
		15-16	27,90	28,70	1,098	1,130	ORTC-274	N-1000-2	
			17-19	28,70	29,60	1,130	1,165	ORTC-283	N-1000-2

TUBE OD		TUBE GAUGE	TUBE ID				TOOL NO.	TOOL BIT	
[INCH]	[MM]		[MM]		[INCH]				
1-1/2	38,10	10-11	31,30	32,10	1,232	1,264	ORTC-309	N-1500-1	
		12-13	32,50	33,30	1,280	1,311	ORTC-320	N-1500-1	
		14-15	33,80	34,50	1,331	1,358	ORTC-333	N-1500-1	
		16-17	34,50	35,30	1,358	1,390	ORTC-339	N-1500-1	
		18-19	35,30	36,10	1,390	1,421	ORTC-350	N-1500-1	
1-3/4	44,45	10-11	37,00	38,50	1,457	1,516	ORTC-369	N-1500-1	
		12-14	38,80	40,30	1,528	1,587	ORTC-383	N-1500-1	
		15-16	40,80	41,20	1,606	1,622	ORTC-403	N-1500-1	
2	50,80	17-18	41,30	42,00	1,626	1,654	ORTC-410	N-1500-1	
		10	44,00	44,00	1,732	1,732	ORTC-435	N-1500-1	
		11	44,70	44,70	1,760	1,760	ORTC-442	N-1500-1	
		12-13	45,00	46,00	1,772	1,811	ORTC-447	N-1500-1	
2-1/4	57,15	14-15	46,20	48,20	1,819	1,898	ORTC-457	N-1500-1	
		16-17	47,20	48,20	1,858	1,898	ORTC-468	N-1500-1	
		18-19	48,00	49,00	1,890	1,929	ORTC-476	N-1500-1	
		10	50,30	50,30	1,980	1,980	ORTC-497	N-2250-1	
2-1/2	63,50	11	51,00	51,00	2,008	2,008	ORTC-505	N-2250-1	
		12-13	51,60	52,30	2,031	2,059	ORTC-511	N-2250-1	
		14-15	52,90	53,50	2,083	2,106	ORTC-524	N-2250-1	
		16-17	53,80	54,80	2,118	2,157	ORTC-533	N-2250-1	
		18-19	54,60	55,60	2,150	2,189	ORTC-541	N-2250-1	
2-1/2	63,50	10	56,70	56,70	2,232	2,232	ORTC-562	N-2250-1	
		11	57,40	57,40	2,260	2,260	ORTC-569	N-2250-1	
		12-13	57,60	58,60	2,268	2,307	ORTC-572	N-2250-1	
		14-15	58,90	60,00	2,319	2,362	ORTC-585	N-2250-1	
		16-17	60,00	61,00	2,362	2,402	ORTC-586	N-2250-1	
			18-19	60,70	61,70	2,390	2,429	ORTC-602	N-2250-1

1WTTC-1000 Wheel Type Tube Cutter

The 1WTTC-1000 greatly reduces cutting time by utilizing the special 1 point self-centering cutter wheel design and works with 3/4", thru 1-1/4" O.D. tubes (after changing cutter body wheels and pilots). The tool does not create any chips during the cutting process!



CUTTING RANGE		REACH		POWER	FREE SPEED	TORQUE	
5/8" to 4"		3" & 6"		1,3 Hp	100 Rpm	105 Ft.Lbs	
15,8 - 101,6 mm		76,2 & 152,4 mm		0,97 kW		140 Nm	
AIR USE		WIDTH		HEIGHT		WEIGHT	
55 cfm	1,3 m³/min	2,32"	59 mm	13,1"	335 mm	15 Lbs	6,8 kg

TRIMMING ATTACHMENT



Tube projection can be cut quickly without generating any chips!

OPTIONAL FEED SYSTEMS



Lever feed handle



Crank arm with double feed stroke

TUBE OD		TUBE GAUGE	TOOL NR	WHEEL HOLDER	WHEEL PIN	CUTTING			TRIMMING			BODY
[INCH]	[MM]	[BWG]				CUTTER WHEEL	PILOT	THRUST COLLAR	TRIMMING COLLAR	PILOT	PILOT EXTENSION	
3/4	19,05	13	1WTTC-750-13	1CCWH-190	CP-20	CW-21	Solid Body	SWTC-750-13	WTTA-750-13	Solid body	Solid body	1WTB-750-13
		14	1WTTC-750	1CCWH-190		CW-21	P-008	SWTC-750	WTTA-750	PE-1WTTC-190	T-8	1WTB-750
		15				CW-21	P-009				T-9	
		16				CW-21	P-010				T-10	
		17				CW-21	P-011				T-11	
		18				CW-21	P-012				T-12	
		19		1CCWH-19-2		CW-21	P-013				T-13	
		20				CW-21	P-014				T-14	
		21				CW-21	P-015				T-15	
		22				CW-21	P-016				T-16	
		23				CW-21	P-017				T-17	
		24				CW-31	P-018				T-18	
7/8	22,23	14	1WTTC-875		1CCWH-222	CP-21	CW-25	P-019	SWTC-875	WTTA-875	PE-1WTTC-222	T-19
		15		CW-25			P-020	T-20				
		16		CW-25			P-021	T-21				
		17		CW-25			P-022	T-22				
		18		CW-25			P-023	T-23				
		19		1CCWH-222-2	CW-25		P-024	T-24				
		20			CW-25		P-025	T-25				
		21			CW-25		P-026	T-26				
		22			CW-25		P-027	T-27				
		23			CW-25		P-028	T-28				

* For 3/4" GA13 the cutting machine needs complete solid body tube cutter 1WTC-750-13

1WTTC-1000 Wheel Type Tube Cutter

TUBE OD		TUBE GAUGE	TOOL NR	WHEEL HOLDER	WHEEL PIN	CUTTING			TRIMMING			BODY
[INCH]	[MM]	[BWG]				CUTTER WHEEL	PILOT	THRUST COLLAR	TRIMMING COLLAR	PILOT	PILOT EXTENSION	
1	25.40	12	1WTTC-1000	1CCWH-254	CP-25	CW-31	P-029-1	SWTC-1000	WTTA-1000	T-29-1	PE-1WTTC-254	1WTB-1000
		13				CW-31	P-029-2			T-29-2		
		14				CW-31	P-029			T-29		
		15				CW-31	P-030			T-30		
		16				CW-31	P-031			T-31		
		17				CW-31	P-032			T-32		
		18	1CCWH-254-2	CW-31	P-033	T-33						
		19		CW-31	P-034	T-34						
		20		CW-31	P-035	T-35						
		21		CW-31	P-036	T-36						
		22		CW-31	P-037	T-37						
		23		CW-31	P-038	T-38						
24	CW-31	P-039	T-39									
1 1/8	28.58	12	1WTTC-1125	1CCWH-286	CP-25	CW-34	P-040-1	SWTC-1125	WTTA-1125	T-40-1	PE-1WTTC-286	1WTB-1125
		13				CW-34	P-040-2			T-40-2		
		14				CW-34	P-040			T-40		
		15				CW-34	P-041			T-41		
		16				CW-34	P-042			T-42		
		17				CW-34	P-043			T-43		
		18	1CCWH-286-2	CW-34	P-044	T-44						
		19		CW-34	P-045	T-45						
		20		CW-34	P-046	T-46						
		21		CW-34	P-047	T-47						
		22		CW-34	P-048	T-48						
		23		CW-34	P-049	T-49						
24	CW-34	P-050	T-50									
1 1/4	31.75	12	1WTTC-1250	1CCWH-317	CP-30	CW-37	P-051	SWTC-1250	WTTA-1250	T-51	PE-1WTTC-317	1WTB-1250
		13				CW-37	P-052			T-52		
		14				CW-37	P-053			T-53		
		15				CW-37	P-054			T-54		
		16				CW-37	P-055			T-55		
		17				CW-37	P-056			T-56		
		18	1CCWH-317-2	CW-37	P-057	T-57						
		19		CW-37	P-058	T-58						
		20		CW-37	P-059	T-59						
		21		CW-37	P-060	T-60						
		22		CW-37	P-061	T-61						
		23		CW-37	P-062	T-62						
24	CW-37	P-063	T-63									
1 1/2	38.1	10	1WTTC-1500	1CCWH-381	CP-4	CW-41	P-064	SWTC-1500	WTTA-1500	T-64	PE-1WTTC-381	1WTB-1500
		11				CW-41	P-065			T-65		
		12				CW-41	P-066			T-66		
		13				CW-41	P-067			T-67		
		14				CW-41	P-068			T-68		
		15				CW-41	P-069			T-69		
		16	1CCWH-383	CW-41	P-070	T-70						
		17		CW-41	P-071	T-71						
		18		CW-41	P-072	T-72						
		19		CW-41	P-073	T-73						
		20		CW-41	P-074	T-74						
		21		CW-41	P-075	T-75						
22	CW-41	P-076	T-76									
23	CW-41	P-077	T-77									
24	CW-41	P-078	T-78									

1WTTC-1000 Wheel Type Tube Cutter

TUBE OD		TUBE GAUGE	TOOL NR	WHEEL HOLDER	WHEEL PIN	CUTTING			TRIMMING		BODY		
[INCH]	[MM]	[BWG]				CUTTER WHEEL	PILOT	THRUST COLLAR	TRIMMING COLLAR	PILOT		PILOT EXTENSION	
1 3/4	44,45	8	1WTTC-1750	1CCWH-444	CP-4	CW-45	P-079	SWTC-1750	WTTA-1750	T-79	PE-1WTTC-444	1WBT-1750	
		9				CW-45	P-080			T-80			
		10				CW-45	P-081			T-81			
		11				CW-45	P-082			T-82			
		12				CW-45	P-083			T-83			
		13				CW-45	P-084			T-84			
		14		1CCWH-445		CW-45	P-085			T-85			
		15				CW-45	P-086			T-86			
		16				CW-45	P-087			T-87			
		17				CW-45	P-088			T-88			
		18				CW-45	P-089			T-89			
		19				CW-45	P-090			T-90			
		20				CW-45	P-091			T-91			
2	50,8	6	1WTTC-2000	1CCWH-508	CP-4	CW-51	P-092	SWTC-2000	WTTA-2000	T-92	PE-1WTTC-508	1WBT-2000	
		7				CW-51	P-093			T-93			
		8				CW-51	P-094			T-94			
		9				CW-51	P-095			T-95			
		10				CW-51	P-096			T-96			
		11				CW-51	P-097			T-97			
		12		1CCWH-506		CW-51	P-098			T-98			
		13				CW-51	P-099			T-99			
		14				CW-51	P-100			T-100			
		15				CW-51	P-101			T-101			
		16				CW-51	P-102			T-102			
		17				CW-51	P-103			T-103			
		18				1CCWH-504	CW-51			P-104			T-104
19	CW-51	P-105	T-105										
20	CW-51	P-106	T-106										
2 1/4	57,1	6	1WTTC-2000	1CCWH-571	CP-4		CW-51	P-107	SWTC-2250	WTTA-2250	T-107	PE-1WTTC-508	1WBT-2000
		7					CW-51	P-108			T-108		
		8				CW-51	P-109	T-109					
		9				CW-51	P-110	T-110					
		10				CW-51	P-111	T-111					
		11				CW-51	P-112	T-112					
		12		1CCWH-573		CW-51	P-113	T-113					
		13				CW-51	P-114	T-114					
		14				CW-51	P-115	T-115					
		15				CW-51	P-116	T-116					
		16				CW-51	P-117	T-117					
		17				CW-51	P-118	T-118					
		18				1CCWH-575	CW-51	P-119			T-119		
19	CW-51	P-120	T-120										
20	CW-51	P-121	T-121										

1WTTC-1000 Wheel Type Tube Cutter

TUBE OD		TUBE GAUGE	TOOL NR	WHEEL HOLDER	WHEEL PIN	CUTTING			TRIMMING			BODY						
[INCH]	[MM]	[BWG]				CUTTER WHEEL	PILOT	THRUST COLLAR	TRIMMING COLLAR	PILOT	PILOT EXTENSION							
2,5	63,5	6	1WTTC-2000	1CCWH-635	CP-4	CW-51	P-122	SWTC-2500	WTTA-2500	T-122	PE-1WTTC-508	1WBT-2000						
		7				CW-51	P-123			T-123								
		8				CW-51	P-124			T-124								
		9				CW-51	P-125			T-125								
		10				CW-51	P-126			T-126								
		11				CW-51	P-127			T-127								
		12				CW-51	P-128			T-128								
		13				1CCWH-637	CW-51			P-129			T-129					
		14					CW-51			P-130			T-130					
		15					CW-51			P-131			T-131					
		16	CW-51	P-132			T-132											
		17	CW-51	P-133			T-133											
		18	1CCWH-639	CW-51			P-134			T-134								
		19		CW-51			P-135			T-135								
		20		CW-51			P-136			T-136								
		3	76,2	6			1WTTC-2000			1CCWH-762			CW-51	P-137	SWTC-3000	WTTA-3000	T-137	PE-1WTTC-508
				7		CW-51							P-138	T-138				
				8		CW-51							P-139	T-139				
				9		CW-51							P-140	T-140				
10	CW-51			P-141	T-141													
11	CW-51			P-142	T-142													
12	CW-51			P-143	T-143													
13	1CCWH-764			CW-51	P-144	T-144												
14				CW-51	P-145	T-145												
15				CW-51	P-146	T-146												
16				CW-51	P-147	T-147												
17				CW-51	P-148	T-148												
18				1CCWH-766	CW-51	P-149	T-149											
19					CW-51	P-150	T-150											
20					CW-51	P-151	T-151											
4				101,6	6	1WTTC-2000	1CCWH-101	CW-51	P-152	SWTC-4000	WTTA-4000	T-152	PE-1WTTC-508	1WBT-2000				
	7				CW-51			P-153	T-153									
	8				CW-51			P-154	T-154									
	9				CW-51			P-155	T-155									
	10	CW-51	P-156		T-156													
	11	CW-51	P-157		T-157													
	12	CW-51	P-158		T-158													
	13	1CCWH-103	CW-51		P-159			T-159										
	14		CW-51		P-160			T-160										
	15		CW-51		P-161			T-161										
	16		CW-51		P-162	T-162												
	17		CW-51		P-163	T-163												
	18		1CCWH-105		CW-51	P-164	T-164											
	19				CW-51	P-165	T-165											
	20				CW-51	P-166	T-166											

2WTTC-1500 Two Wheels Type Tube Cutter

The 2WTTC-1500 greatly reduces cutting time by utilizing the special 2 point self-centering cutter wheel design and works from 1-1/2" up to 2" O.D. tubes. The tool does not create any chips during the cutting process!



CUTTING RANGE		REACH		POWER	FREE SPEED		TORQUE	
1-1/2" to 2"		4"		1,3 Hp	100 Rpm		105 Ft.Lbs	
38,1 - 50,8 mm		101,6 mm		0,97 kW			140 Nm	
AIR USE			WIDTH		HEIGHT		WEIGHT	
55 cfm	1,3 m ³ /min	2,32"	59 mm	13,1"	335 mm	21 Lbs	9,5 kg	

OPTIONAL FEED SYSTEMS



Lever feed handle



Crank arm single feed stroke

ALL-PURPOSE TOOL

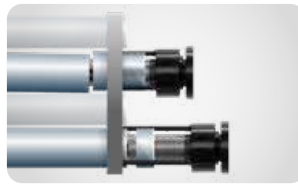

Tube cutting and tube trimming setup-set-up

TUBE OD		TUBE GAUGE	CUTTER WHEEL	WHEEL HOLDER	WHEEL PIN	PILOT	SUPPORT PILOT	THRUST COLLAR	COLAR DEPTH STOP	
[INCH]	[MM]	[BWG]							LONG	SHORT
1 1/2	38.1	12	CW-13	2CWH-15	CP-3	2P-29	SP-29	TC-300	TCDS-L	TCDS-S
		13				2P-291	SP-291			
		14				2P-30	SP-30			
		15				2P-301	SP-301			
		16				2P-31	SP-31			
		17				2P-311	SP-311			
		18				2P-32	SP-32			
		19				2P-321	SP-321			
		20				2P-33	SP-33			
		21				2P-331	SP-331			
		22				2P-332	SP-332			
		23				2P-333	SP-333			
24	2P-334	SP-334								
1 3/4	44.45	12	CW-16	2CWH-18	CP-4	2P-35	SP-35	TC-250	TCDS-L	TCDS-S
		13				2P-351	SP-351			
		14				2P-36	SP-36			
		15				2P-361	SP-361			
		16				2P-37	SP-37			
		17				2P-371	SP-371			
		18				2P-38	SP-38			
		19				2P-381	SP-381			
		20				2P-382	SP-382			
		21				2P-383	SP-383			
		22				2P-384	SP-384			
		23				2P-385	SP-385			
24	2P-386	SP-386								

2WTTC-1500 Two Wheels Type Tube Cutter

TUBE OD		TUBE GAUGE	CUTTER WHEEL	WHEEL HOLDER	WHEEL PIN	PILOT	SUPPORT PILOT	THRUST COLLAR	COLAR DEPTH STOP	
[INCH]	[MM]	[BWG]							LONG	SHORT
2	50.80	8	CW-17	2CWH-20	CP-4	2P-40	SP-40	TC-200	TCDS-L	TCDS-S
		9				2P-401	SP-401			
		10				2P-41	SP-41			
		11				2P-411	SP-411			
		12				2P-42	SP-42			
		13				2P-421	SP-421			
		14				2P-43	SP-43			
		15				2P-431	SP-431			
		16				2P-44	SP-44			
		17				2P-441	SP-441			
		18				2P-45	SP-45			
		19				2P-451	SP-451			
		20				2P-46	SP-46			
		21				2P-461	SP-461			
		22				2P-47	SP-47			
		23				2P-471	SP-471			
24	2P-48	SP-48								

3WTTC-2000 Three Wheels Type Tube Cutter

The 3WTTC-2000 greatly reduces cutting time by utilizing the special 3 point self-centering cutter wheel design and works with 2", thru 4" O.D. tubes. The tool does not create any chips during the cutting process!

Depending on operator experience and tube material the KRAIS 3WTTC-2000 can cut 2" GA 12 in between 6 to 12 seconds. Real tube to tube cycle time is approximately 30 seconds, giving unmatched productivity.



CUTTING RANGE		REACH		POWER		FREE SPEED		TORQUE	
2" - 4"		4"		1,3 Hp		100 Rpm		105 Ft.Lbs	
50,8 - 101,6 mm		101,6 mm		0,97 kW				140 Nm	
AIR USE			WIDTH		HEIGHT		WEIGHT		
55 cfm	1,3 m ³ /min	2,32"	59 mm	13,1"	335 mm	23 Lbs	10,42 kg		

OPTIONAL FEED SYSTEMS



Lever feed handle



Crank arm single feed stroke

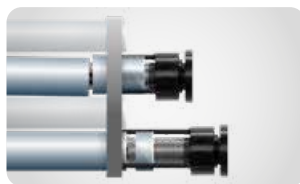

Tube cutting and tube trimming setup-set-up



On demand we offer 3WTTC with reach up to 5 m.

ALL-PURPOSE TOOL

TUBE OD		TUBE GAUGE	CUTTER WHEEL	WHEEL HOLDER	WHEEL PIN	PILOT EXTENSION	PILOT	THRUST COLLAR	COLAR DEPTH STOP	
[INCH]	[MM]	[BWG]							LONG	SHORT
2	50,8	10	CW-16	CCWH-20	CP-4	PE-WTTC	P42	TC-200	TCDS-L	TCDS-S
		11								
		12								
		13								
		14								
		15								
		16								
		17								
		18								
		19								
2 1/4	57,15	9	CW-17	CCWH-22	CP-4	PE-WTTC	P51	TC-200	TCDS-L	TCDS-S
		10								
		11								
		12								
		13								
		14								
		15								
		16								
		17								
		18								
19										
20										
20										
P52										
P53										
P54										
P55										
P56										
P561										
P57										
P571										
P58										
P581										
P59										

3WTTC-2000 Three Wheels Type Tube Cutter

TUBE OD		TUBE GAUGE	CUTTER WHEEL	WHEEL HOLDER	WHEEL PIN	PILOT EXTENSION	PILOT	THRUST COLLAR	COLAR DEPTH STOP	
[INCH]	[MM]	[BWG]							LONG	SHORT
2 1/2	63.50	9	CW-17	CCWH-25	CP-4	PE-WTTC	P51	TC-200	TCDS-L	TCDS-S
		10								
		11								
		12								
		13								
		14								
		15								
		16								
		17								
		18								
		19								
3	76.20	9	CW-17	CCWH-30	CP-4	PE-WTTC	P61	TC-200	TCDS-L	TCDS-S
		10								
		11								
		12								
		13								
		14								
		15								
		16								
		17								
		18								
		19								
3 1/2	88.90	9	CW-17	CCWH-35	CP-4	PE-WTTC	P71	TC-400	TCDS-L	TCDS-S
		10								
		11								
		12								
		13								
		14								
		15								
		16								
		17								
		18								
		19								
4	101.60	9	CW-17	CCWH-40	CP-4	PE-WTTC	P81	TC-400	TCDS-L	TCDS-S
		10								
		11								
		12								
		13								
		14								
		15								
		16								
		17								
		18								
		19								
20										

3WTTC-3000 Three Wheels Tube Cutter

The 3WTTC-3000 greatly reduces cutting time by utilizing the special 3 point self-centering cutter wheel design and works with 2-1/2", thru 5" O.D. tubes. The tool does not create any chips during the cutting process! "Real life" tube to tube cycle time is approximately 30 seconds, giving unmatched productivity.



CUTTING RANGE		REACH		POWER	FREE SPEED	TORQUE	
2,5" - 5"		4"		1,3 Hp	55 Rpm	207 Ft.Lbs	
63,5 - 127,0 mm		101,6 mm		0,97 kW		280 Nm	
AIR USE		WIDTH		HEIGHT		WEIGHT	
55 cfm	1,3 m ³ /min	2,32"	59 mm	19"	485 mm	36,3 Lbs	16,5 kg

OPTIONAL FEED SYSTEMS



Lever feed handle



Crank arm with double feed stroke

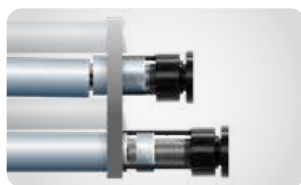

Tube cutting and tube trimming setup-set-up

ALL-PURPOSE TOOL

TUBE OD		TUBE GAUGE	CUTTER WHEEL	WHEEL HOLDER	WHEEL PIN	PILOT EXTENSION	PILOT	THRUST COLLAR	COLLAR DEPTH	
[INCH]	[MM]	[BWG]							LONG	SHORT
2 1/2	63.50	8	CW-19	CCWH-55	CP-4	PE-WTTC-3	P350	TC-3200	TCDS-L	TCDS-S
		9								
		10								
		11								
		12								
		13								
		14								
		15								
		16								
		17								
18										
19										
20										
3	76.20	6	CW-22	CCWH-60	CP-5	PE-WTTC-3	P3606	TC-3200	TCDS-L	TCDS-S
		7								
		8								
		9								
		10								
		11								
		12								
		13								
		14								
		15								
16										
17										
18										
19										
20										
3	76.20	13	CW-22	CCWH-60	CP-5	PE-WTTC-3	P365	TC-3200	TCDS-L	TCDS-S
		14								
		15								
		16								
		17								
		18								
		19								
		20								
		P3661								
		P367								
P3671										
P368										
P3681										
P369										

MWTTTC – Manual Tube Cutter

Tool designed for cutting or partial cutting of tubes in center support sheets of condensers, including units of Trane, Carrier, and JCI type.

The MWTTTC is equipped with adjustable wheel travel, allowing precise control of cutting depth. The operator can easily set the cut to approximately 98% of the tube wall thickness, ensuring controlled operation without damage to adjacent components. The standard tool reach is 10 ft (3 m). Extended versions up to 39 ft (12 m) are available on request for long tube bundle applications.



For efficient tube removal, the MCP-100 Manual Collet Puller is recommended as a companion tool, enabling quick and reliable extraction of tube stubs and full tubes.

CUTTING RANGE	REACH	POWER
19-25 mm	3 m	Manual
3/4" - 1"	10 ft	

CUTTING WITHOUT CHIPS



TUBE OD		TUBE GAUGE	TOOL NR	WHEEL HOLDER	WHEEL PIN	CUTTING		
[INCH]	[MM]	[BWG]				CUTTER WHEEL	PILOT	THRUST COLLAR
3/4	19.05	14	MWTTTC-750	1CCWH-190	CP-20	CW-21	P-008	MWTC-750
		15				CW-21	P-009	
		16				CW-21	P-010	
		17				CW-21	P-011	
		18				CW-21	P-012	
		19		1CCWH-19-2		CW-21	P-013	
		20				CW-21	P-014	
		21				CW-21	P-015	
		22				CW-21	P-016	
		23				CW-21	P-017	
7/8	22.23	14	MWTTTC-875	1CCWH-222	CP-25	CW-31	P-018	MWTC-875
		15				CW-25	P-019	
		16				CW-25	P-020	
		17				CW-25	P-021	
		18				CW-25	P-022	
		19		1CCWH-222-2		CW-25	P-023	
		20				CW-25	P-024	
		21				CW-25	P-025	
		22				CW-25	P-026	
		23				CW-25	P-027	
1	25.40	12	MWTTTC-1000	1CCWH-254	CP-25	CW-25	P-028	MWTC-1000
		13				CW-31	P-029-1	
		14				CW-31	P-029-2	
		15				CW-31	P-029	
		16				CW-31	P-030	
		17		CW-31		P-031		
		18		1CCWH-254-2		CW-31	P-032	
		19				CW-31	P-033	
		20				CW-31	P-034	
		21				CW-31	P-035	
22	CW-31	P-036						
23	CW-31	P-037						
24	CW-31	P-038						
						CW-31	P-039	

3WTTC-3000 Three Wheels Tube Cutter

TUBE OD		TUBE GAUGE	CUTTER WHEEL	WHEEL HOLDER	WHEEL PIN	PILOT EXTENSION	PILOT	THRUST COLLAR	COLAR DEPTH	
[INCH]	[MM]	[BWG]							LONG	SHORT
3 1/2	88.90	6	CW-22	CCWH-65	CP-5	PE-WTTC-3	P3716	TC-3400	TCDS-L	TCDS-S
		7								
		8								
		9								
		10								
		11								
		12								
		13								
		14								
		15								
		16								
		17								
		18								
19										
20										
4	101.60	6	CW-22	CCWH-70	CP-5	PE-WTTC-3	P3806	TC-3400	TCDS-L	TCDS-S
		7								
		8								
		9								
		10								
		11								
		12								
		13								
		14								
		15								
		16								
		17								
		18								
19										
20										
5	127	6	CW-22	CCWH-80	CP-5	PE-WTTC-3	P3906	TC-3500	TCDS-L	TCDS-S
		7								
		8								
		9								
		10								
		11								
		12								
		13								
		14								
		15								
		16								
		17								
		18								
19										
20										

Tube wall reducing tool

The WTRT is a tube sheet reamer manufactured from high-speed steel (HSS), featuring a Morse Taper shank and a centralizing pilot ground to match the specific tube gauge. The tool is designed to reduce the outer diameter of tubes prior to their removal from the tube sheet, enabling clean extraction without damaging the tube sheet bore.

During the reaming process, tubes should be drilled to approximately 80% of the tube sheet thickness. This ensures sufficient material removal for tube release while preserving the structural integrity of the tube sheet.

The WTRT is intended for use with the KDM pneumatic drill.

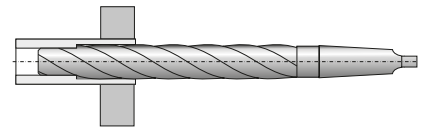

TUBE O.D.		TUBE GAUGE	TUBE I.D.		TOOL NO.	MORSE TAPER	TUBE SHEET THICKNESS	
[INCH]	[MM]	[BWG]	[INCH]	[MM]			[INCH]	[MM]
1/2	12,7	16	0,370	9,40	WTRT-1	2	2-7/8"	73
		17	0,384	9,75	WTRT-2	2	2-7/8"	73
		18	0,402	10,21	WTRT-3	2	2-7/8"	73
		19	0,415	10,56	WTRT-4	2	2-7/8"	73
5/8	15,8	12	0,407	10,34	WTRT-5	2	3-3/8"	86
		13	0,435	11,05	WTRT-6	2	3-3/8"	86
		14	0,459	11,66	WTRT-7	2	3-3/8"	86
		15	0,481	12,22	WTRT-8	2	3-3/8"	86
		16	0,495	12,57	WTRT-9	2	3-3/8"	86
		18	0,527	13,39	WTRT-10	2	3-3/8"	86
3/4	19	10	0,482	12,24	WTRT-11	2	4-3/8"	111
		11	0,510	12,95	WTRT-12	2	4-3/8"	111
		12	0,532	13,51	WTRT-13	2	4-3/8"	111
		13	0,560	14,22	WTRT-14	2	4-3/8"	111
		14	0,584	14,83	WTRT-15	2	4-3/8"	111
		15	0,606	15,39	WTRT-16	2	4-3/8"	111
		16	0,620	15,75	WTRT-17	2	4-3/8"	111
		18	0,652	16,56	WTRT-18	2	4-3/8"	111
7/8	22,2	10	0,607	15,42	WTRT-19	2	4-5/8"	117
		11	0,635	16,13	WTRT-20	2	4-5/8"	117
		12	0,657	16,69	WTRT-21	2	4-5/8"	117
		13	0,685	17,40	WTRT-22	2	4-5/8"	117
		14	0,709	18,01	WTRT-23	2	4-5/8"	117
		15	0,731	18,57	WTRT-24	2	4-5/8"	117
		16	0,745	18,92	WTRT-25	2	4-5/8"	117
		18	0,777	19,74	WTRT-26	2	4-5/8"	117

TUBE O.D.		TUBE GAUGE	TUBE I.D.		TOOL NO.	MORSE TAPER	TUBE SHEET THICKNESS	
[INCH]	[MM]	[BWG]	[INCH]	[MM]			[INCH]	[MM]
1	25,4	8	0,670	17,02	WTRT-27	3	5-1/2"	140
		10	0,732	18,59	WTRT-28	3	5-1/2"	140
		11	0,760	19,30	WTRT-29	3	5-1/2"	140
		12	0,782	19,86	WTRT-30	3	5-1/2"	140
		13	0,810	20,57	WTRT-31	3	5-1/2"	140
		14	0,834	21,18	WTRT-32	3	5-1/2"	140
		15	0,856	21,74	WTRT-33	3	5-1/2"	140
		16	0,870	22,10	WTRT-34	3	5-1/2"	140
		18	0,902	22,91	WTRT-35	3	5-1/2"	140
		1-1/4	31,7	8	0,92	23,37	WTRT-36	3
10	0,982			24,94	WTRT-37	3	5-1/2"	140
11	1,010			25,65	WTRT-38	3	5-1/2"	140
12	1,032			26,21	WTRT-39	3	5-1/2"	140
13	1,060			26,92	WTRT-40	3	5-1/2"	140
14	1,084			27,53	WTRT-41	3	5-1/2"	140
16	1,12			28,45	WTRT-42	3	5-1/2"	140
18	1,152			29,26	WTRT-43	4	5-1/2"	140
1-1/2	38,1	8	1,170	29,72	WTRT-44	4	5-1/2"	140
		10	1,232	31,29	WTRT-45	4	5-1/2"	140
		11	1,260	32,00	WTRT-46	4	5-1/2"	140
		12	1,282	32,56	WTRT-47	4	5-1/2"	140
		13	1,310	33,27	WTRT-48	4	5-1/2"	140
		14	1,334	33,88	WTRT-49	4	5-1/2"	140
		16	1,370	34,80	WTRT-50	4	5-1/2"	140

Modular tube wall reducing tool



This HSS modular reamer features a Morse Taper shank and a precision-ground pilot tailored to the specific tube gauge. Engineered for deep-reach applications, it utilizes screw-in extensions to facilitate gauge reduction in thick or double tube sheets, as well as finned coolers. Designed for tube removal, the tool enables drilling of up to 80% of the tube sheet thickness, ensuring efficient extraction.



TUBE OD		TUBE GAUGE	TUBE ID		TOOL NO.	TOOL OD		EXTENSION	MORSE TAPER
[INCH]	[MM]	[BWG]	[INCH]	[MM]		[INCH]	[MM]		
3/4	19	10	0,482	12,24	MWTRT-1034	0,736	18,7	MWTRT-EXT34-XX	MWTRT-MT3
		11	0,510	12,95	MWTRT-1134	0,736	18,7		
		12	0,532	13,51	MWTRT-1234	0,736	18,7		
		13	0,560	14,22	MWTRT-1334	0,736	18,7		
		14	0,584	14,83	MWTRT-1434	0,736	18,7		
1	25,4	8	0,670	17,02	MWTRT-0825	0,972	24,7	MWTRT-EXT25-XX	
		10	0,732	18,59	MWTRT-1025	0,972	24,7		
		11	0,760	19,30	MWTRT-1125	0,972	24,7		
		12	0,782	19,86	MWTRT-1225	0,972	24,7		
		13	0,810	20,57	MWTRT-1325	0,972	24,7		
		14	0,834	21,18	MWTRT-1425	0,972	24,7		

EXTENSION FOR FINFAN APPLICATIONS



An extension shaft (FF-WTRT-EXTxx), fitted with a dedicated locking nut that secures the tool within the FinFan tube sheet bore to prevent lateral movement and ensure axial alignment during operation.

AVAILABLE EXTENSION LENGTHS

MODEL	LENGTH	
	[MM]	[INCH]
WTRT-EXTxx-6	152,4	6"
WTRT-EXTxx-8	203,2	8"
WTRT-EXTxx-10	254,0	10"
WTRT-EXTxx-12	305,0	12"

MiniMill-301-WTRT

TUBE WALL REDUCING TOOL

Precise reduction of tube stub wall for easy removal

The MiniMill-301-WTRT is designed to simplify one of the most critical and time-consuming stages of heat exchanger retubing — the removal of heavy-wall tube stubs from the tube sheet. Instead of forcing out strongly bonded stubs, the tool reduces the remaining wall thickness in a controlled manner. This significantly lowers the expansion grip, allowing the stub to be removed cleanly and predictably using standard tube drifts.

KEY APPLICATION

- ▶ Heat exchanger retubing
- ▶ Removal of expanded or seized tube stubs
- ▶ Situations with: corrosion bonding, over-expanded joints, serrated tube ends.

OPERATIONAL BENEFITS

- ▶ Lower extraction force required
- ▶ Reduced vibration during operation
- ▶ Minimal risk of chip packing and tool stalling
- ▶ Improved process stability and repeatability
- ▶ Faster and more predictable workflow



WORKING RANGE		FEED STROKE		POWER	FREE SPEED	TORQUE	
APPLICATION RANGE	LOCKING RANGE						
19,05 and 24,4 mm	16,90 – 23,0 mm	25 mm	0,787»	1,3 HP	300 RPM	43 Nm	32 ft.lbs
3/4" and 1"	0,488 – 0,945"						
AIR USE		BODY WIDTH		BODY HEIGHT		BODY WEIGHT	
55 cfm	1,3 m ³ /min	2,32"	59 mm	13,1"	335 mm	15,4 Lbs	7 kg

TOOLING CHART FOR 3/4" TUBE

TUBE OD		TOOL NUMBER	TOOL DIAMETER		DRILLING LENGTH*	
[INCH]	[MM]		[INCH]	[MM]	[INCH]	[MM]
3/4"	19,05	MDWTRT-180	0,709	18,0	2,5"	63,5 mm

* maximum depth is achieved in three passes

TOOLING CHART FOR 1" TUBE

TUBE OD		TOOL NUMBER	TOOL DIAMETER		DRILLING LENGTH*	
[INCH]	[MM]		[INCH]	[MM]	[INCH]	[MM]
1"	25,40	MDWTRT-245	0,965	24,3	2,5"	63,5 mm

* maximum depth is achieved in three passes

LOCKING JAWS FOR 3/4" TUBE

JAWS	RANGE [MM]		RANGE [INCH]		SPRING
	MIN	MAX	MIN	MAX	
309MM#36	13,00	14,00	0,512	0,551	DW-10
311MM#36	14,00	15,00	0,551	0,591	O-9
313MM#36	15,00	16,00	0,591	0,630	O-9
317MM#36	16,00	17,00	0,630	0,669	O-10

LOCKING JAWS FOR 1" TUBE

JAWS	RANGE [MM]		RANGE [INCH]		SPRING
	MIN	MAX	MIN	MAX	
207 MM#36	16,90	19,00	0,665	0,748	DW-15,5
209 MM#36	18,90	21,00	0,744	0,827	DW-15,5
211 MM#36	19,90	22,00	0,783	0,866	DW-15,5
213 MM#36	20,90	23,00	0,823	0,906	DW-15,5
214 MM#36	21,90	24,00	0,862	0,944	DW-15,5



POSITION IN WORKFLOW

Designed for heavy-wall tubing: when corrosion or seizing leaves no grip for extraction, the tool bores out the tube wall to loosen the joint and provide a better purchase for removal.

MiniDrill-500-WTRT

High-Performance Tube Wall Reduction Machine

The MiniDrill-500-WTRT-AC is engineered for rapid and reliable tube wall reduction across a variety of demanding materials — from carbon steel and stainless steel to tough alloys like Inconel in the heat exchanger

KEY FEATURES:

- ▶ Three carbide cutting inserts, each with four cutting edges for maximum durability and efficiency.
- ▶ Operating speed: 500 RPM
- ▶ Torque output: 120 Nm – ensures strong and consistent cutting performance
- ▶ Standard air cooling system – helps maintain optimal cutting temperature and prolong tool life.
- ▶ Efficient Tension Relief: Releases approximately 75% of expansion tension, allowing for easy stub removal using a TD tube drift or CT collapsing tool.

Optional fast-change configuration includes:

- ▶ two pneumatic locks for quick, secure machine setup;
- ▶ ideal for high-throughput maintenance tasks.

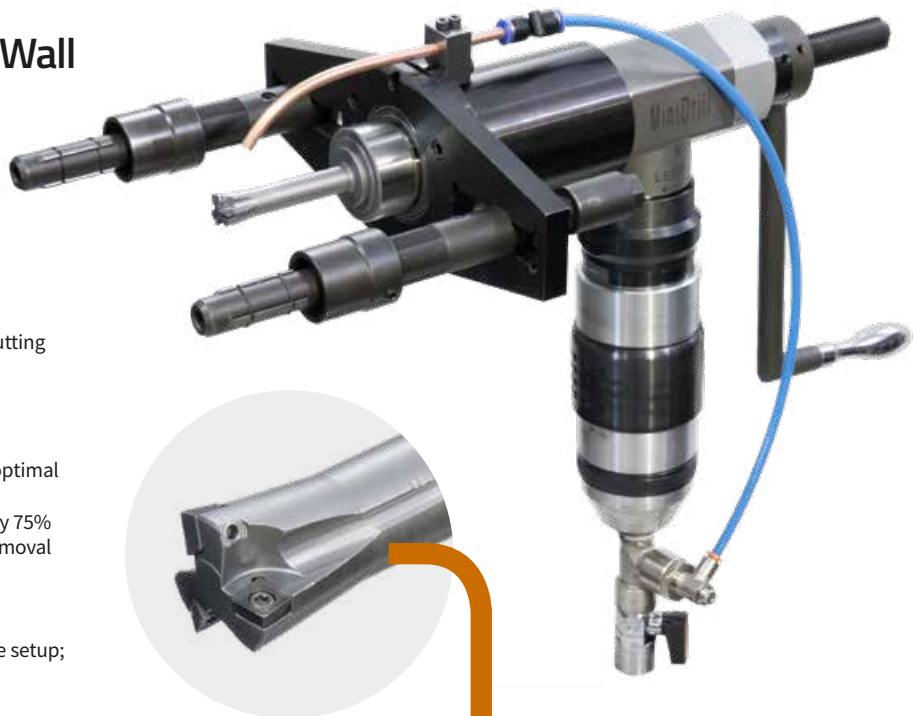

TYPICAL USE CASES

- ▶ Tube wall reduction for easy removal from the heat exchanger tube sheet.
- ▶ Perfect for removing corrosion and reaming out damaged tube ends in heat exchangers to prepare the surface for secure and effective plugging.
- ▶ Especially useful in power plants, refineries, and chemical processing facilities where quick maintenance turnaround is critical.

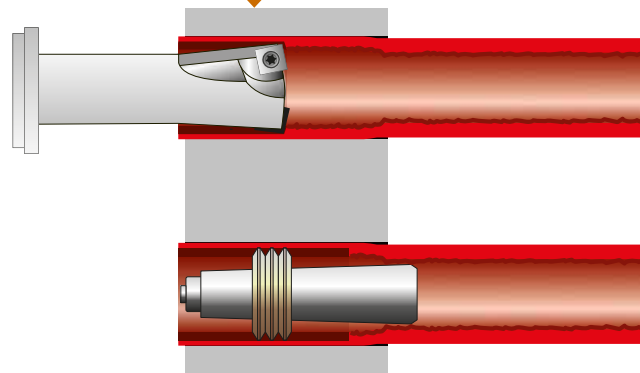

TOOLING CHART

TUBE OD		TOOL NUMBER	TOOL DIAMETER		DRILLING LENGTH		NO. OF INSERTS
[INCH]	[MM]		[INCH]	[MM]	[INCH]	[MM]	
5/8"	15,88	MDWTRT-148	0,583	14,8	2,5"	63,5 mm	2
3/4"	19,05	MDWTRT-180	0,709	18,0	2,5"	63,5 mm	3
7/8"	22,22	MDWTRT-210	0,827	21,0	2,5"	63,5 mm	3
1"	25,40	MDWTRT-245	0,965	24,5	2,5"	63,5 mm	3
1-1/4"	31,75	MDWTRT-307	1,209	30,7	2,5"	63,5 mm	3
1-1/2"	38,10	MDWTRT-371	1,461	37,1	2,5"	63,5 mm	3

TOOLS FOR FIN-FAN COOLERS

A dedicated version is also available for Fin-Fan coolers, with length customized to fit the header size—perfect for retubing 1" tubes with ease and precision.



PRECISION LOCKING SYSTEM INCLUDED

The machine comes standard with two locking plates:

- ▶ For 3/4" tubes with 1" hole pitch
- ▶ For 1" tubes with 1-1/4" hole pitch



Other configurations are available upon request. To ensure maximum accuracy and protect the tube sheet, we machine the tube to 0.5 mm (0.019") clearance. For this reason, we do not recommend using adjustable locking plates, as improper adjustment can lead to tube sheet hole damage.

OPTIONAL PNEUMATIC LOCKING SYSTEM

For even faster setup and improved efficiency, we offer an optional set of two pneumatic locks. This upgrade enables quick and secure locking, saving valuable time during operations—especially useful in high-volume or repetitive tasks.



Pneumatic Chipping hammer

TD Tube Drifts and CT Collapsing tools are very good tools for quick removal of tube stubs from the tube sheet. For tube 1/2" to 1" OD tools are made as standard. The tools are equipped with shank O6. Other sizes available on request. The O1 shank and tool with reach longer than 6" available on request. Other sizes, up to 2" available on request.



RAM STROKE		RAM FREQUENCY		RAM DIAMETER	
80 mm		33 Hz		40 mm	
3,149"				1,574"	
AIR USE		LENGTH WITHOUT TOOL		BODY WEIGHT	
### cfm	25 m ³ /min	16,141"	410 mm	9,48 Lbs	4,3 kg



TD Tube drift



SHANK TYPE O6

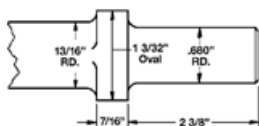

CT Collapsing tool

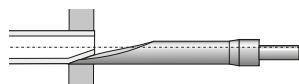

TUBE O.D.		TUBE GAUGE			TOOL WITH SHANK O6
[INCH]	[MM]	[BWG]	[MM]	[INCH]	
3/8"	10	16 - 20	1,65 - 0,89	0,065 - 0,035	CT-375-06
1/2"	12,7				CT-500-06
5/8"	15,8				CT-625-06
3/4"	19,05				CT-750-06
7/8"	22,2				CT-875-06
1"	25,4				CT-1000-06
1-1/4"	31,7				CT-1125-06
1-1/2"	38,1				CT-1500-06
1-3/4"	44,4				CT-1750-06
2"	50,8				CT-2000-06

TUBE O.D.		TUBE GAUGE		TUBE I.D.		TOOL WITH SHANK O6	
[INCH]	[MM]	[BWG]	[INCH]	[MM]	[INCH]		
1/2	12,7	12	0,109	2,77	0,281	7,16	TD-500-12-06
		14	0,083	2,11	0,333	8,48	TD-500-14-06
		16	0,065	1,65	0,370	9,40	TD-500-16-06
		18	0,049	1,24	0,402	10,22	TD-500-18-06
		20	0,035	0,89	0,429	10,92	TD-500-20-01
5/8	15,8	12	0,109	2,77	0,407	10,34	TD-625-12-06
		13	0,095	2,41	0,435	11,05	TD-625-13-06
		14	0,083	2,11	0,459	11,66	TD-625-14-06
		15	0,072	1,83	0,481	12,22	TD-625-15-06
		16	0,065	1,65	0,495	12,57	TD-625-16-06
		17	0,058	1,47	0,509	12,93	TD-625-17-06
		18	0,049	1,24	0,527	13,39	TD-625-18-06
3/4	19	19	0,042	1,07	0,541	13,74	TD-625-19-06
		20	0,035	0,89	0,555	14,10	TD-625-20-06
		10	0,134	3,40	0,482	12,24	TD-750-10-06
		12	0,109	2,77	0,532	13,51	TD-750-12-06
		13	0,095	2,41	0,560	14,22	TD-750-13-06
		14	0,083	2,11	0,584	14,83	TD-750-14-06
		15	0,072	1,83	0,606	15,39	TD-750-15-06
		16	0,065	1,65	0,620	15,75	TD-750-16-06
		17	0,058	1,47	0,634	16,10	TD-750-17-06
		18	0,049	1,24	0,652	16,56	TD-750-18-06
7/8	22,2	19	0,042	1,07	0,666	16,92	TD-750-19-06
		20	0,035	0,89	0,680	17,27	TD-750-20-06
		12	0,109	2,77	0,657	16,69	TD-875-12-06
		14	0,083	2,11	0,709	18,01	TD-875-14-06
		15	0,072	1,83	0,731	18,57	TD-875-15-06
		16	0,065	1,65	0,745	18,92	TD-875-16-06
1	25,4	18	0,049	1,24	0,777	19,74	TD-875-18-06
		8	0,165	4,19	0,670	17,02	TD-1000-8-06
		9	0,148	3,76	0,704	17,88	TD-1000-9-06
		10	0,134	3,40	0,732	18,59	TD-1000-10-06
		11	0,120	3,05	0,760	19,30	TD-1000-11-06
		12	0,109	2,77	0,782	19,86	TD-1000-12-06
		13	0,095	2,41	0,810	20,57	TD-1000-13-06
		14	0,083	2,11	0,834	21,18	TD-1000-14-06
		15	0,072	1,83	0,856	21,74	TD-1000-15-06
		16	0,065	1,65	0,870	22,10	TD-1000-16-06
		17	0,058	1,47	0,884	22,45	TD-1000-17-06
		18	0,049	1,24	0,902	22,91	TD-1000-18-06
19	0,042	1,07	0,916	23,27	TD-1000-19-06		
20	0,035	0,89	0,930	23,62	TD-1000-20-06		

HyperDrill BSR

HyperDrill BSR is a unique machining platform. The machine is designed to carry out many machining operations on boilers and similar thermal exchange equipment. With 80 mm (3.150") tool travel, this machine is ideally suited for most plants and is designed with operator safety in mind.

The system is fully torque-resistant with 2 or 3 clamping shafts that are independent of one another and can accommodate most pitch configurations. Once locked into the drum, the HyperDrill BSR is exceptionally stable.



AVAILABLE DRIVES



HYDRAULIC MOTOR (RECOMMENDED)

MOTOR	SPEED	POWER	TORQUE	OIL PRESSURE		MIN. OIL FLOW RATE	
	RPM	HP	NM	BAR	PSI	LT/MIN	GPM
HTB-165	343	16,7	273	190	2750	57	15



PNEUMATIC MOTOR

MOTOR	REVER-SIBLE	RIGHT-ANGLE	SPEED	TORQUE		SQUARE DRIVE
			RPM	NM	FT.LBS	
K75-RL-3V-190	YES	YES	190	190	140	120, 210, 380, 650



ELECTRIC MOTOR

MOTOR	REVER-SIBLE	RIGHT-ANGLE	SPEED	POWER	TORQUE	VOLTAGE
			RPM	WATT	NM	V
DUDE-2000 4 speed	YES	YES	120, 210, 380, 650	2000	240	110/230

AVAILABLE TOOLING

Solid drill (on request)



Drilling heads with inserts for stub wall reduction (1-1/4" to 4-1/2")



Adjustable boring heads for oversizing damaged holes (1-1/4" to 5")



Grooving tools (1-1/4" to 4")



Weld removal heads (1-1/4" to 4-1/2")

OPTIONAL ACCESORIES**FAST CLAMPING SYSTEM**

System offers rapid tube to tube cycle time, increased productivity (up to 4x) with little operator fatigue. Ideal for large amount of end preps.

EXAMPLE APPLICATIONS

- ▶ boiler tube and stubs wall reduction before punching it down;
- ▶ weld removal from stubs outside of the drum, especially for thin wall drums where the end prep machine can't be locked;
- ▶ boring the drum holes with a precise head for oversizing them for the repair of damaged or oval holes;
- ▶ trepanation of the drum or pipes;
- ▶ drilling holes (need chain clamping).





Pulling Equipment

HETT – Tube Taping Machine

The HETT tapping machine solves problems with retubing heat exchangers tubes made of hard alloyed steel such as Inconel, duplex, other stainless steel or thick-walled carbon steel tubes. The unique characteristic of the HETT machine is a high torque, up to 450 Nm, and the tool is easy to operate by one person.

The machine uses the short version of standard machine tapping tools.



Using the HETT solution eliminates the traditional taper spears and noisy impact wrenches. Once the thread is ready, an operator can use any tube of pullers, such as HPR-30, SupperJenny, ACTP, or custom made CP-1000 puller.



The only difference is that a threaded drawbar is used, which guarantees a strong connection with pulled tubes and a long tool lifetime in comparing the traditional tube spear.



WORK EXAMPLES



Another advantage of threading tube end in the tube sheet is that by cutting grooves in the tube wall, we weaken the expanded connection, making it much easier to break that expansion with a tube puller.

Manual Tube Pullers

Manual Tube Puller



TUBE OD		[BWG]	WALL THKS		TUBE ID		TUBE PULLER NO	SPARE SPEARS NO
[INCH]	[MM]		[INCH]	[MM]	[INCH]	[MM]		
1/2	12,7	14	0,08	2,11	0,334	8,48	KSPN 500-14	KSP 1/2-14
		16	0,07	1,65	0,370	9,40	KSPN500-16	KSP 1/2-16
		18	0,05	1,24	0,402	10,21	KSPN 500-18	KSP 1/2-18
		20	0,04	0,89	0,430	10,92	KSPN 500-20	KSP 1/2-20
5/8	15,88	14	0,08	2,11	0,459	11,66	KSPN 625-14	KSP 5/8-14
		16	0,07	1,65	0,495	12,57	KSPN 625-16	KSP 5/8-16
		18	0,05	1,24	0,527	13,39	KSPN 625-18	KSP 5/8-18
		20	0,04	0,89	0,555	14,10	KSPN 625-20	KSP 5/8-20
3/4	19,05	14	0,08	2,11	0,585	14,86	KSPN 750-14	KSP 3/4-14
		16	0,07	1,65	0,620	15,75	KSPN 750-16	KSP 3/4-16
		18	0,05	1,24	0,652	16,56	KSPN 750-18	KSP 3/4-18
		20	0,04	0,89	0,680	17,27	KSPN 750-20	KSP 3/4-20
7/8	22,2	14	0,08	2,11	0,709	18,01	KSPN 875-14	KSP 7/8-14
		16	0,07	1,65	0,745	18,92	KSPN 875-16	KSP 7/8-16
		18	0,05	1,24	0,777	19,74	KSPN 875-18	KSP 7/8-18
		20	0,04	0,89	0,805	20,45	KSPN 875-20	KSP 7/8-20
1	25,4	14	0,08	2,11	0,834	21,18	KSPN 1000-14	KSP 1-14
		16	0,07	1,65	0,870	22,10	KSPN 1000-16	KSP 1-16
		18	0,05	1,24	0,902	22,91	KSPN 1000-18	KSP 1-18
		20	0,04	0,89	0,930	23,62	KSPN 1000-20	KSP 1-20

2-FUNCTION RATCHED HANDLE

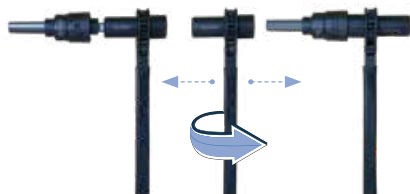

MSP-100 Manual Spear Puller



Easy and economical way for tube removal.

- ▶ Easy to use by inserting the spear into the tube and removing required just a hand wrench or our universal ratched handle design for this operation (the drive handle it's a separate item and must be ordered separately).
- ▶ No external power required.
- ▶ Durable - all parts made out of high strength steel and are heat treated.
- ▶ Only one tool body required to cover the range form 1/2" to 1". Required only spears and nose pieces.

TUBE OD		TUBE GAUGE	SPEARS	NOSE PIECE
[INCH]	[MM]	[BWG]		
1/2	12,7	14-15	CPS-12-14-15	CPS-10-06A-12
		16-17	CPS-12-16-17	
		18-19	CPS-12-18-19	
		20-22	CPS-12-20-22	
		22-24	CPS-12-22-24	
5/8	15,88	10-11	CPS-58-10-11	CPS-10-06A-34
		12-13	CPS-58-12-13	
		14-15	CPS-58-14-15	
3/4	19,05	10-11	CPS-34-10-11	CPS-10-06A-34
		12-13	CPS-34-12-13	
		14-15	CPS-34-14-15	
7/8	22,23	10-11	CPS-78-10-11	CPS-10-06A-78
		12-13	CPS-78-12-13	
		14-15	CPS-78-14-15	
1	25,4	10-11	CPS-1-10-11	CPS-10-06A-1
		12-13	CPS-1-12-13	
		14-15	CPS-1-14-15	
		16-17	CPS-1-16-17	

Manual Tube Pullers

MCP-100 Manual Collet Puller

MCP-100 manual collet type tube puller for quick and easy tube stub removal from heat exchanges, condensers, chillers and other tubular pressure vessels.

Manually operated develop up to 10 Tons pulling force (depend on the arm length of the ratchet wrench), with 4" stroke. Can be used for tubes form 5/8" (16mm) to 1" (25 mm) O.D.



Recommended for smaller amount of tube to be pulled.

TUBE OD		TUBE GAUGE	GRIPPER SET	DRAW MANDREL	NOSE PIECE	LOCK NUT	ADJUST NUT	JAW O'RING	C O'RING
[INCH]	[MM]	[BWG]							
5/8"	15,88	16-17	CP-1000-01-58-16	CP-10S-03-58	CP-10L-06A-58	CP-10-LN-58	CP-10-AN-58	CP-2220	CP-1724
		18-19	CP-1000-01-58-18	CP-10S-03-58	CP-10L-06A-58	CP-10-LN-58	CP-10-AN-58	CP-2220	CP-1724
		20-21	CP-1000-01-58-20	CP-10S-03-58	CP-10L-06A-58	CP-10-LN-58	CP-10-AN-58	CP-2220	CP-1724
		22-23	CP-1000-01-58-22	CP-10S-03-58	CP-10L-06A-58	CP-10-LN-58	CP-10-AN-58	CP-2220	CP-1724
3/4"	19,05	16-17	CP-1000-01-34-16	CP-10S-03-34	CP-10L-06A-34	CP-10-LN-34	CP-10-AN-34	CP-2220	CP-1724
		18-19	CP-1000-01-34-18	CP-10S-03-34	CP-10L-06A-34	CP-10-LN-34	CP-10-AN-34	CP-2220	CP-1724
		20-21	CP-1000-01-34-20	CP-10S-03-34	CP-10L-06A-34	CP-10-LN-34	CP-10-AN-34	CP-2220	CP-1724
		22-23	CP-1000-01-34-22	CP-10S-03-34	CP-10L-06A-34	CP-10-LN-34	CP-10-AN-34	CP-2220	CP-1724
7/8"	22,23	16-17	CP-1000-01-78-16	CP-10S-03-78	CP-10L-06A-78	CP-10-LN-78	CP-10-AN-78	CP-2220	CP-1724
		18-19	CP-1000-01-78-18	CP-10S-03-78	CP-10L-06A-78	CP-10-LN-78	CP-10-AN-78	CP-2220	CP-1724
		20-21	CP-1000-01-78-20	CP-10S-03-78	CP-10L-06A-78	CP-10-LN-78	CP-10-AN-78	CP-2220	CP-1724
		22-23	CP-1000-01-78-22	CP-10S-03-78	CP-10L-06A-78	CP-10-LN-78	CP-10-AN-78	CP-2220	CP-1724
1"	25,4	16-17	CP-1000-01-1-16	CP-10S-03-1	CP-10L-06A-1	CP-10-LN-1	CP-10-AN-1	CP-2220	CP-1724
		18-19	CP-1000-01-1-18	CP-10S-03-1	CP-10L-06A-1	CP-10-LN-1	CP-10-AN-1	CP-2220	CP-1724
		20-21	CP-1000-01-1-20	CP-10S-03-1	CP-10L-06A-1	CP-10-LN-1	CP-10-AN-1	CP-2220	CP-1724
		22-23	CP-1000-01-1-22	CP-10S-03-1	CP-10L-06A-1	CP-10-LN-1	CP-10-AN-1	CP-2220	CP-1724

Tube Puller HCP-5T

HCP-100 hydraulic collet-type tube puller

Collet-type hydraulic tube puller – engineered for the extraction of tube stubs from heat exchangers, condensers, and chillers.

This ultra-lightweight machine was designed with a focus on portability and a compact footprint, making it the ideal tool for maintenance environments where space is at a premium and the workload involves a limited number of tubes.

Unit operates in single-acting mode, utilizing an integrated spring-return mechanism to reset the puller to its starting position.



KEY TECHNICAL SPECIFICATIONS

- ▶ **Operating range:** optimized for tube diameters from 5/8" (16 mm) to 1" (25 mm) O.D.
- ▶ **Stroke length:** features a precision 6" (152,4 mm) stroke for consistent extraction.
- ▶ **Power compatibility:** highly versatile pump integration; the HCP-100 is designed to operate seamlessly with compact manual hand pumps or standard pneumatic-hydraulic electric power units.
- ▶ **Application:** recommended for low-volume extraction tasks and precision remedial work in tubular pressure vessels.

PULLING FORCE	PULLING STROKE	PULLING SPEED	
49 kN	152,4 mm	Depends on used pump	
5 T	6"		
BODY DIMENSIONS		BODY WEIGHT	
2.04" x 27.6"	52 x 700 mm	10.5 Lbs	4,80 kg

TUBE OD		TUBE GAUGE	GRIPPER SET	DRAW MANDREL	NOSE PIECE	LOCK NUT	ADJUST NUT	JAW O'RING	C O'RING
[INCH]	[MM]	[BWG]							
5/8"	15,88	16-17	CP-1000-01-58-16	CP-10S-03-58	CP-10L-06A-58	CP-10-LN-58	CP-10-AN-58	CP-2220	CP-1724
		18-19	CP-1000-01-58-18	CP-10S-03-58	CP-10L-06A-58	CP-10-LN-58	CP-10-AN-58	CP-2220	CP-1724
		20-21	CP-1000-01-58-20	CP-10S-03-58	CP-10L-06A-58	CP-10-LN-58	CP-10-AN-58	CP-2220	CP-1724
		22-23	CP-1000-01-58-22	CP-10S-03-58	CP-10L-06A-58	CP-10-LN-58	CP-10-AN-58	CP-2220	CP-1724
3/4"	19,05	16-17	CP-1000-01-34-16	CP-10S-03-34	CP-10L-06A-34	CP-10-LN-34	CP-10-AN-34	CP-2220	CP-1724
		18-19	CP-1000-01-34-18	CP-10S-03-34	CP-10L-06A-34	CP-10-LN-34	CP-10-AN-34	CP-2220	CP-1724
		20-21	CP-1000-01-34-20	CP-10S-03-34	CP-10L-06A-34	CP-10-LN-34	CP-10-AN-34	CP-2220	CP-1724
		22-23	CP-1000-01-34-22	CP-10S-03-34	CP-10L-06A-34	CP-10-LN-34	CP-10-AN-34	CP-2220	CP-1724
7/8"	22,23	16-17	CP-1000-01-78-16	CP-10S-03-78	CP-10L-06A-78	CP-10-LN-78	CP-10-AN-78	CP-2220	CP-1724
		18-19	CP-1000-01-78-18	CP-10S-03-78	CP-10L-06A-78	CP-10-LN-78	CP-10-AN-78	CP-2220	CP-1724
		20-21	CP-1000-01-78-20	CP-10S-03-78	CP-10L-06A-78	CP-10-LN-78	CP-10-AN-78	CP-2220	CP-1724
		22-23	CP-1000-01-78-22	CP-10S-03-78	CP-10L-06A-78	CP-10-LN-78	CP-10-AN-78	CP-2220	CP-1724
1"	25,4	16-17	CP-1000-01-1-16	CP-10S-03-1	CP-10L-06A-1	CP-10-LN-1	CP-10-AN-1	CP-2220	CP-1724
		18-19	CP-1000-01-1-18	CP-10S-03-1	CP-10L-06A-1	CP-10-LN-1	CP-10-AN-1	CP-2220	CP-1724
		20-21	CP-1000-01-1-20	CP-10S-03-1	CP-10L-06A-1	CP-10-LN-1	CP-10-AN-1	CP-2220	CP-1724
		22-23	CP-1000-01-1-22	CP-10S-03-1	CP-10L-06A-1	CP-10-LN-1	CP-10-AN-1	CP-2220	CP-1724

AVAILABLE PUMPS

For proper work this tool require single-acting pump.



Manual hydraulic pump



Pneumatic hydraulic pump



Electric 230V hydraulic pump

Tube Puller CP-1200

Shortened version of our model CP-1000. This unit has been designed to remove both ferrous and non-ferrous tubing from condensers, chillers and heat exchangers. Capacity from 5/8" to 1-1/2" O.D. gage 16 to 24 (16 to 38 mm O.D. wall 0,5 to 1,6 mm) from tube sheet up to 2" (50 mm)



PULLING FORCE		PULLING STROKE		PULLING SPEED	
120 kN		160 mm		17 mm/sec	
12 T		6"		0,7"/sec.	
BODY DIMENSIONS			BODY WEIGHT		
3,38" x 26,77"		86 x 680 mm		30 Lbs / 13,5 kg	

CPSCK-1000



For this tool we offer a spears type conversion kit.

TUBE OD	TUBE GAUGE	MIN ENTER DIM AFTER EXP.		MAX ENTER DIM AFTER EXP.		GRIPPER SET	DRAW MANDREL	NOSE PIECE	LOCK NUT	ADJUST NUT	JAW O'RING	C O'RING	
		[INCH]	[MM]	[INCH]	[MM]								
5/8	15,88	16-17	0,506	12,85	0,545	13,84	CP-1000-01-58-16	CP-10S-03-58	CP-10S-06A-58	CP-10-LN-58	CP-10-AN-58	CP-2220	CP-1724
		18-19	0,535	13,59	0,574	14,58	CP-1000-01-58-18						
		20-21	0,562	14,27	0,602	15,29	CP-1000-01-58-20						
		22-23	0,576	14,63	0,616	15,65	CP-1000-01-58-22						
3/4	19,05	16-17	0,631	16,03	0,671	17,04	CP-1000-01-34-16	CP-10S-03-34	CP-10S-06A-34	CP-10-LN-34	CP-10-AN-34	CP-2220	CP-1724
		18-19	0,665	16,89	0,704	17,88	CP-1000-01-34-18						
		20-21	0,692	17,58	0,732	18,59	CP-1000-01-34-20						
		22-23	0,706	17,93	0,746	18,95	CP-1000-01-34-22						
7/8	22,23	16-17	0,755	19,18	0,795	20,19	CP-1000-01-78-16	CP-10S-03-78	CP-10S-06A-78	CP-10-LN-78	CP-10-AN-78	CP-2220	CP-1724
		18-19	0,787	19,99	0,826	20,98	CP-1000-01-78-18						
		20-21	0,815	20,70	0,854	21,69	CP-1000-01-78-20						
		22-23	0,828	21,03	0,868	22,05	CP-1000-01-78-22						
1	25,4	16-17	0,881	22,38	0,921	23,39	CP-1000-01-1-16	CP-10S-03-1	CP-10S-06A-1	CP-10-LN-1	CP-10-AN-1	CP-2220	CP-1724
		18-19	0,913	23,19	0,952	24,18	CP-1000-01-1-18						
		20-21	0,941	23,90	0,980	24,89	CP-1000-01-1-20						
		22-23	0,972	24,69	1,011	25,68	CP-1000-01-1-22						
1-1/4*	31,75	16-17	1,133	28,78	1,173	29,79	CP-1000-01-114-16	CP-10S-03-114	CP-10S-06A-114	CP-10-LN-114	CP-10-AN-114	CP-2220	CP-1724
		18-19	1,165	29,59	1,204	30,58	CP-1000-01-114-18						
		20-21	1,194	30,33	1,234	31,34	CP-1000-01-114-20						
		22-23	1,208	30,68	1,248	31,70	CP-1000-01-114-22						
1-1/2*	38,10	16-17	1,385	35,18	1,425	36,20	CP-1000-01-112-16	CP-10S-03-112	CP-10S-06A-112	CP-10-LN-112	CP-10-AN-112	CP-2220	CP-1724
		18-19	1,417	35,99	1,456	36,98	CP-1000-01-112-18						
		20-21	1,444	36,68	1,484	37,69	CP-1000-01-112-20						
		22-23	1,458	37,03	1,498	38,05	CP-1000-01-112-22						

* For tubes 1-1/4" i 1-1/2" SS7-381 adapter and SS10-381 joint are required!

Tube Puller CP-1200-CC



This is our lightweight unit, specifically designed for the condenser and chiller markets. An ideal tool for working within the water box of a surface condenser or within the channel head of a chiller, you can remove 4-6 tubes a minute quickly and effortlessly. Capacity from 5/8" to 1" OD, gage 16 to 24 (16 to 25 mm OD, wall 0,5 to 1,6 mm) from tube sheet up to 2" (50 mm).

PULLING FORCE	PULLING STROKE	PULLING SPEED	
150 kN	160 mm	17 mm/sec	
15 T	6"	0,7"/sec.	
BODY DIMENSIONS		BODY WEIGHT	
3,38" x 26,77"	86 x 680 mm	26,4 Lbs	12 kg

TUBE OD		TUBE GAUGE	MIN ENTER DIM AFTER EXP.		MAX ENTER DIM AFTER EXP.		GRIPPER SET	DRAW MANDREL	NOSE PIECE	LOCK NUT	ADJUST NUT	JAW O'RING	C O'RING
[INCH]	[MM]		[INCH]	[MM]	[INCH]	[MM]							
5/8	15,88	16-17	0,506	12,85	0,545	13,84	CP-1000-01-58-16	CP-10S-03-58	CP-10L-06A-58	CP-10-LN-58	CP-10-AN-58	CP-2220	CP-1724
		18-19	0,535	13,59	0,574	14,58	CP-1000-01-58-18						
		20-21	0,562	14,27	0,602	15,29	CP-1000-01-58-20						
		22-23	0,576	14,63	0,616	15,65	CP-1000-01-58-22						
3/4	19,05	16-17	0,631	16,03	0,671	17,04	CP-1000-01-34-16	CP-10S-03-34	CP-10L-06A-34	CP-10-LN-34	CP-10-AN-34	CP-2220	CP-1724
		18-19	0,665	16,89	0,704	17,88	CP-1000-01-34-18						
		20-21	0,692	17,58	0,732	18,59	CP-1000-01-34-20						
		22-23	0,706	17,93	0,746	18,95	CP-1000-01-34-22						
7/8	22,23	16-17	0,755	19,18	0,795	20,19	CP-1000-01-78-16	CP-10S-03-78	CP-10L-06A-78	CP-10-LN-78	CP-10-AN-78	CP-2220	CP-1724
		18-19	0,787	19,99	0,826	20,98	CP-1000-01-78-18						
		20-21	0,815	20,70	0,854	21,69	CP-1000-01-78-20						
		22-23	0,828	21,03	0,868	22,05	CP-1000-01-78-22						
1	25,4	16-17	0,881	22,38	0,921	23,39	CP-1000-01-1-16	CP-10S-03-1	CP-10L-06A-1	CP-10-LN-1	CP-10-AN-1	CP-2220	CP-1724
		18-19	0,913	23,19	0,952	24,18	CP-1000-01-1-18						
		20-21	0,941	23,90	0,980	24,89	CP-1000-01-1-20						
		22-23	0,972	24,69	1,011	25,68	CP-1000-01-1-22						

Non standard sizes on request

RECOMMENDED PUMPS

Three pump choice with parameters of 700 bar (1000 psi) oil delivery at high pressure 0,9 to 1,1 l/min:

- ▶ electric 230 V standard type
- ▶ electric 230 V with oil cooler
- ▶ pneumatic 1,4 cu.m/min at 6 bar



Tube Puller CP-1200-FF



This unit has all the features of our Standard Model CP-1000 with the additional advantage of being able to remove stubs from the waterbox of Fin Fan Coolers as well as tubes/stubs close to the shell or pass partition plates within thermal exchange units. A standard waterbox depth of X is furnished with custom depths available upon request. Capacity from 5/8" to 1-1/2" O.D. gage 16 to 38 (16 to 38 mm O.D. wall 0,5 to 1,6 mm) from tube sheet up to 2" (50 mm)

PULLING FORCE	PULLING STROKE	PULLING SPEED	
150 kN	160 mm	17 mm/sec	
15 T	6"	0,7"/sec.	
BODY DIMENSIONS		BODY WEIGHT	
3,38" x 36,61"	86 x 930 mm	32 Lbs	14,5 kg

TUBE OD		TUBE GAUGE	MIN ENTER DIM AFTER EXP.		MAX ENTER DIM AFTER EXP.		GRIPPER SET	DRAW MANDREL	NOSE PIECE	LOCK NUT	ADJUST NUT	JAW O'RING	CO'RING	JAWS HOLDER	MANDREL EXT.
[INCH]	[MM]		[INCH]	[MM]	[INCH]	[MM]									
5/8	15,88	16-17	0,506	12,85	0,545	13,84	CP-1000-01-58-16	CP-10L-03-58	CP-10S-06A-58	CP-10-LN-58	CP-10-AN-58	CP-2220	CP-1724	CP-JH-58-10"	CP-10-DM-EXT
		18-19	0,535	13,59	0,574	14,58	CP-1000-01-58-18								
		20-21	0,562	14,27	0,602	15,29	CP-1000-01-58-20								
		22-23	0,576	14,63	0,616	15,65	CP-1000-01-58-22								
3/4	19,05	16-17	0,631	16,03	0,671	17,04	CP-1000-01-34-16	CP-10L-03-34	CP-10S-06A-34	CP-10-LN-34	CP-10-AN-34	CP-2220	CP-1724	CP-JH-34-10"	CP-10-DM-EXT
		18-19	0,665	16,89	0,704	17,88	CP-1000-01-34-18								
		20-21	0,692	17,58	0,732	18,59	CP-1000-01-34-20								
		22-23	0,706	17,93	0,746	18,95	CP-1000-01-34-22								
7/8	22,23	16-17	0,755	19,18	0,795	20,19	CP-1000-01-78-16	CP-10L-03-78	CP-10S-06A-78	CP-10-LN-78	CP-10-AN-78	CP-2220	CP-1724	CP-JH-78-10"	CP-10-DM-EXT
		18-19	0,787	19,99	0,826	20,98	CP-1000-01-78-18								
		20-21	0,815	20,70	0,854	21,69	CP-1000-01-78-20								
		22-23	0,828	21,03	0,868	22,05	CP-1000-01-78-22								
1	25,4	16-17	0,881	22,38	0,921	23,39	CP-1000-01-1-16	CP-10L-03-1	CP-10S-06A-1	CP-10-LN-1	CP-10-AN-1	CP-2220	CP-1724	CP-JH-1-10"	CP-10-DM-EXT
		18-19	0,913	23,19	0,952	24,18	CP-1000-01-1-18								
		20-21	0,941	23,90	0,980	24,89	CP-1000-01-1-20								
		22-23	0,972	24,69	1,011	25,68	CP-1000-01-1-22								
1-1/4	31,75	16-17	1,133	28,78	1,173	29,79	CP-1000-01-114-16	CP-10L-03-114	CP-10S-06A-114	CP-10-LN-114	CP-10-AN-114	CP-2220	CP-1724	CP-JH-58-114"	CP-10-DM-EXT
		18-19	1,165	29,59	1,204	30,58	CP-1000-01-114-18								
		20-21	1,194	30,33	1,234	31,34	CP-1000-01-114-20								
		22-23	1,208	30,68	1,248	31,70	CP-1000-01-114-22								
1-1/2	38,10	16-17	1,385	35,18	1,425	36,20	CP-1000-01-112-16	CP-10L-03-112	CP-10S-06A-112	CP-10-LN-112	CP-10-AN-112	CP-2220	CP-1724	CP-JH-58-114"	CP-10-DM-EXT
		18-19	1,417	35,99	1,456	36,98	CP-1000-01-112-18								
		20-21	1,444	36,68	1,484	37,69	CP-1000-01-112-20								
		22-23	1,458	37,03	1,498	38,05	CP-1000-01-112-22								

We can supply the FF conversion kit to your specifications on all models of the CP-1000 and CP-1000-S.

Tube Puller HPR20-CP1000

HPR20-CP1000 is a machine designed to pull tube stubs from heat exchangers in the oil refinery industry, and we recommend it for removing heavy wall tubes. The device uses modern spear-type jaws for smooth and fast pulling. HPR20-CP1000 is convenient and fast in operation with low operating costs. HPR20-CP1000 delivers capacity from 5/8" to 1" gauge 10 to 16, with max pulling force up to 20 tons from the tube sheet up to 2,5" (63 mm)



WORKING RANGE	PULLING FORCE	PULLING STROKE	PULLING SPEED
15,8 to 25,4 mm	200 kN	100 mm	34 mm/sec
5/8" to 1"	20 T	4"	1,33"/sec.
BODY DIMENSIONS		BODY WEIGHT	
4,7" x 31,5"	120 x 800 mm	85 Lbs	22 kg

UNIQUE DESIGN

The device uses modern spear-type jaws for smooth and fast pulling and offers high capacity in operating range.



Tube OD		Tube gauge	Gripper Set	Draw Mandrel	Nose Piece	Jaw o'ring	NS Joint	Adapter	Max Force	Pump
[inch]	[mm]	[BWG]								(700 Bar)
5/8"	15,8	14	CP-1500-01-58-14	CP-15-02-U	CP-15-03-58	CP-15-058	CP-15-06-58	CP-15-07-34	15 ton	CPPZ-4W
		15	CP-1500-01-58-15	CP-15-02-U	CP-15-03-58	CP-15-058	CP-15-06-58	CP-15-07-34	15 ton	CPPZ-4W
		16	CP-1500-01-58-16	CP-15-02-U	CP-15-03-58	CP-15-058	CP-15-06-58	CP-15-07-34	15 ton	CPPZ-4W
		17	CP-1500-01-58-17	CP-15-02-U	CP-15-03-58	CP-15-058	CP-15-06-58	CP-15-07-34	15 ton	CPPZ-4W
		18	CP-1500-01-58-18	CP-15-02-U	CP-15-03-58	CP-15-058	CP-15-06-58	CP-15-07-34	15 ton	CPPZ-4W
		19	CP-1500-01-58-19	CP-15-02-U	CP-15-03-58	CP-15-058	CP-15-06-58	CP-15-07-34	15 ton	CPPZ-4W
		20	CP-1500-01-58-20	CP-15-02-U	CP-15-03-58	CP-15-058	CP-15-06-58	CP-15-07-34	15 ton	CPPZ-4W
		21	CP-1500-01-58-21	CP-15-02-U	CP-15-03-58	CP-15-058	CP-15-06-58	CP-15-07-34	15 ton	CPPZ-4W
3/4"	19,05	12	CP-1500-01-34-12	CP-15-02-U	CP-15-03-34	CP-15-034	CP-15-06-34	CP-15-07-34	20 ton	CPPZ-4W
		13	CP-1500-01-34-13	CP-15-02-U	CP-15-03-34	CP-15-034	CP-15-06-34	CP-15-07-34	20 ton	CPPZ-4W
		14	CP-1500-01-34-14	CP-15-02-U	CP-15-03-34	CP-15-034	CP-15-06-34	CP-15-07-34	20 ton	CPPZ-4W
		15	CP-1500-01-34-15	CP-15-02-U	CP-15-03-34	CP-15-034	CP-15-06-34	CP-15-07-34	20 ton	CPPZ-4W
		16	CP-1500-01-34-16	CP-15-02-U	CP-15-03-34	CP-15-034	CP-15-06-34	CP-15-07-34	20 ton	CPPZ-4W
		17	CP-1500-01-34-17	CP-15-02-U	CP-15-03-34	CP-15-034	CP-15-06-34	CP-15-07-34	20 ton	CPPZ-4W
		18	CP-1500-01-34-18	CP-15-02-U	CP-15-03-34	CP-15-034	CP-15-06-34	CP-15-07-34	20 ton	CPPZ-4W
		19	CP-1500-01-34-19	CP-15-02-U	CP-15-03-34	CP-15-034	CP-15-06-34	CP-15-07-34	20 ton	CPPZ-4W
		20	CP-1500-01-34-20	CP-15-02-U	CP-15-03-34	CP-15-034	CP-15-06-34	CP-15-07-34	20 ton	CPPZ-4W
		21	CP-1500-01-34-21	CP-15-02-U	CP-15-03-34	CP-15-034	CP-15-06-34	CP-15-07-34	20 ton	CPPZ-4W
7/8"	22,2	12	CP-1500-01-78-12	CP-15-02-U	CP-15-03-78	CP-15-034	CP-15-06-34	CP-15-07-34	20 ton	CPPZ-4W
		13	CP-1500-01-78-13	CP-15-02-U	CP-15-03-78	CP-15-034	CP-15-06-34	CP-15-07-34	20 ton	CPPZ-4W
		14	CP-1500-01-78-14	CP-15-02-U	CP-15-03-78	CP-15-034	CP-15-06-34	CP-15-07-34	20 ton	CPPZ-4W
		15	CP-1500-01-78-15	CP-15-02-U	CP-15-03-78	CP-15-034	CP-15-06-34	CP-15-07-34	20 ton	CPPZ-4W
		16	CP-1500-01-78-16	CP-15-02-U	CP-15-03-78	CP-15-034	CP-15-06-34	CP-15-07-34	20 ton	CPPZ-4W
		17	CP-1500-01-78-17	CP-15-02-U	CP-15-03-78	CP-15-034	CP-15-06-34	CP-15-07-34	20 ton	CPPZ-4W
18	CP-1500-01-78-18	CP-15-02-U	CP-15-03-78	CP-15-034	CP-15-06-34	CP-15-07-34	20 ton	CPPZ-4W		

Tube Puller HPR20-CP1000

Tube OD		Tube gauge	Gripper Set	Draw Mandrel	Nose Piece	Jaw o'ring	NS Joint	Adapter	Max Force	Pump (700 Bar)
[inch]	[mm]	[BWG]								
1"	25,4	8	CP-1500-01-1-8	CP-15-02-U	CP-15-03-1	CP-15-034	CP-15-06-34	CP-15-07-34	30 ton	CPPZ-4W
		8	CP-1500-01-1-9	CP-15-02-U	CP-15-03-1	CP-15-034	CP-15-06-34	CP-15-07-34	30 ton	CPPZ-4W
		10	CP-1500-01-1-10	CP-15-02-U	CP-15-03-1	CP-15-034	CP-15-06-34	CP-15-07-34	30 ton	CPPZ-4W
		11	CP-1500-01-1-11	CP-15-02-U	CP-15-03-1	CP-15-034	CP-15-06-34	CP-15-07-34	30 ton	CPPZ-4W
		12	CP-1500-01-1-12	CP-15-02-U	CP-15-03-1	CP-15-034	CP-15-06-34	CP-15-07-34	30 ton	CPPZ-4W
		13	CP-1500-01-1-13	CP-15-02-U	CP-15-03-1	CP-15-034	CP-15-06-34	CP-15-07-34	30 ton	CPPZ-4W
		14	CP-1500-01-1-14	CP-15-02-U	CP-15-03-1	CP-15-034	CP-15-06-34	CP-15-07-34	30 ton	CPPZ-4W
		15	CP-1500-01-1-15	CP-15-02-U	CP-15-03-1	CP-15-034	CP-15-06-34	CP-15-07-34	30 ton	CPPZ-4W
		16	CP-1500-01-1-16	CP-15-02-U	CP-15-03-1	CP-15-034	CP-15-06-34	CP-15-07-34	30 ton	CPPZ-4W
		17	CP-1500-01-1-17	CP-15-02-U	CP-15-03-1	CP-15-034	CP-15-06-34	CP-15-07-34	30 ton	CPPZ-4W
		18	CP-1500-01-1-18	CP-15-02-U	CP-15-03-1	CP-15-034	CP-15-06-34	CP-15-07-34	30 ton	CPPZ-4W
19	CP-1500-01-1-19	CP-15-02-U	CP-15-03-1	CP-15-034	CP-15-06-34	CP-15-07-34	30 ton	CPPZ-4W		
20	CP-1500-01-1-20	CP-15-02-U	CP-15-03-1	CP-15-034	CP-15-06-34	CP-15-07-34	30 ton	CPPZ-4W		

RECOMMENDED PUMPS

Three pump choice with parameters of 700 bar (1000 psi) oil delivery at high pressure 0,9 to 1,1 l/min:

- ▶ electric 230 V standard type
- ▶ electric 230 V with oil cooler
- ▶ pneumatic 1,4 cu.m/min at 6 bar



SPINAIR COMPATIBILITY



Tube puller may cooperate with SpinAir-2H with spherical rolls .

HPR-CP2000 Tube Puller

HPR-CP2000 KRAIS gripper-type tube puller is designed for pulling 1-1/4" thru 2-1/2" OD tubes in heat exchangers and fire tube boilers. This gripper type tube puller makes tube pulling faster and easier. See selection charts below for ordering grippers, draw bars and components for the tube sizes being pulled.



PULLING FORCE		PULLING STROKE		PULLING SPEED	
300 kN		160 mm		34 mm/sec	
30 T		6"		1,33"/sec.	
BODY DIMENSIONS			BODY WEIGHT		
4,7" x 31,5"		120 x 800 mm		85 Lbs	39 kg

TUBE OD		TUBE GAUGE	GRIPPER SET	DRAW MANDREL	NOSE PIECE	LOCK NUT	ADJUST NUT	JAW O'RING	JOINT	ADAPTER	JAWS LOCKING RING	SPRING
[INCH]	[MM]											
1-1/4	31,75	12	CP-2000-01-114-12	CP-30-02-114	CP-30-03-114	CP-30-04-114	CP-30-05-114	CP-30-0114	CP-30-06-112	CP-30-07-112	CP-30-08-112	CP-30-09-112
		13	CP-2000-01-114-13									
		14	CP-2000-01-114-14									
		15-16	CP-2000-01-114-15									
		17-18	CP-2000-01-114-17									
1-1/2	38,10	8	CP-2000-01-112-8	CP-30-02-112	CP-30-03-112	CP-30-04-112	CP-30-05-112	CP-30-0112	CP-30-06-112	CP-30-07-112	CP-30-08-112	CP-30-09-112
		9	CP-2000-01-112-9									
		10	CP-2000-01-112-10									
		11	CP-2000-01-112-11									
		12	CP-2000-01-112-12									
		13	CP-2000-01-112-13									
		14	CP-2000-01-112-14									
		15-16	CP-2000-01-112-15									
17-18	CP-2000-01-112-17											
1-3/4	44,45	8	CP-2000-01-175-8	CP-30-02-175	CP-30-03-175	CP-30-04-175	CP-30-05-175	CP-30-0175	CP-30-06-200	CP-30-07-200	CP-30-08-200	CP-30-09-200
		9	CP-2000-01-175-9									
		10	CP-2000-01-175-10									
		11	CP-2000-01-175-11									
		12	CP-2000-01-175-12									
		13	CP-2000-01-175-13									
		14	CP-2000-01-175-14									
15-16	CP-2000-01-175-15											
2	50,80	6	CP-2000-01-200-6	CP-30-02-200	CP-30-03-200	CP-30-04-200	CP-30-05-200	CP-30-0200	CP-30-06-200	CP-30-07-200	CP-30-08-200	CP-30-09-200
		7	CP-2000-01-200-7									
		8	CP-2000-01-200-8									
		9	CP-2000-01-200-9									
		10	CP-2000-01-200-10									
		11	CP-2000-01-200-11									
		12	CP-2000-01-200-12									
		13	CP-2000-01-200-13									
		14	CP-2000-01-200-14									
15-16	CP-2000-01-200-15											
17-18	CP-2000-01-200-17											

TUBE OD		TUBE GAUGE	GRIPPER SET	DRAW MANDREL	NOSE PIECE	LOCK NUT	ADJUST NUT	JAW O'RING	JOINT	ADAPTER	JAWS LOCKING RING	SPRING
[INCH]	[MM]											
2-1/4	57,15	6	CP-2000-01-225-6	CP-30-02-225	CP-30-03-225	CP-30-04-225	CP-30-05-225	CP-30-0225	CP-30-06-250	CP-30-07-250	CP-30-08-250	CP-30-09-250
		7	CP-2000-01-225-7									
		8	CP-2000-01-225-8									
		9	CP-2000-01-225-9									
		10	CP-2000-01-225-10									
		11	CP-2000-01-225-11									
		12	CP-2000-01-225-12									
		13	CP-2000-01-225-13									
		14	CP-2000-01-225-14									
		15-16	CP-2000-01-225-15									
17-18	CP-2000-01-225-17											
2-1/2	63,50	6	CP-2000-01-250-6	CP-30-02-250	CP-30-03-250	CP-30-04-250	CP-30-05-250	CP-30-0250	CP-30-06-250	CP-30-07-250	CP-30-08-250	CP-30-09-250
		7	CP-2000-01-250-7									
		8	CP-2000-01-250-8									
		9	CP-2000-01-250-9									
		10	CP-2000-01-250-10									
		11	CP-2000-01-250-11									
		12	CP-2000-01-250-12									
		13	CP-2000-01-250-13									
		14	CP-2000-01-250-14									
		15-16	CP-2000-01-250-15									
17-18	CP-2000-01-250-16											

RECOMMENDED PUMPS

Three pump choice with parameters of 700 bar (1000 psi) oil delivery at high pressure 0,9 to 1,1 l/min:

- ▶ electric 230 V standard type
- ▶ electric 230 V with oil cooler
- ▶ pneumatic 1,4 cu.m/min at 6 bar



Super-Jenny Semi-Automatic Tube Puller

Super-Jenny Series of hydraulic, semi-automatic tube pullers, allows the user to continuously pull tubes through heat exchangers, condensers and boilers, without the use of hammers or winches etc. The key to the system is the OD gripping jaw that will pull the tube as the operator actuates the ram.



12-TON "MINI-JENNY"

Smallest puller, has been specifically designed for chiller and condenser work. Weighing in at just 18 lbs. (6 kg), this 10-ton capacity ram can pull up to 1" OD tubes. With a 3" stroke, this unit is exceptionally quick, and is ideal for tight access applications.

20-TON "SUPER-JENNY"

Available with either a 3" or 6" stroke. This tool is capable of pulling 5/8" - 1" tubes continuously.

30-TON "SUPER-JENNY"

30-ton puller is the workhorse of industry. Available with either a 3" or 6" stroke. This tool is capable of pulling 5/8" - 1-1/4" tubes continuously. It can even pull up to 3" stubs in specific applications.

60-TON "SUPER-JENNY"

Biggest 60-ton "Super-Jenny" has been designed to pull tubes in the toughest applications. As standard, the unit can pull 1/2"-2" tubes. As a special, an adapter is offered which will allow the operator to pull smaller diameter tubes with up to 60 tons of pulling force. For example, a tube extraction of 1 1/4" x 10 BWG with a 7" tube sheet was noted to pull at 52 tons of pulling force.

12 TON "MINI-JENNY"

TUBE OD		TUBE GAUGE	PULLING SPEAR	PULLING JAW	NOSE COLLAR	O-RING	JAW SPRING	SPEAR-MALE
[INCH]	[MM]							
5/8"	15,88	13-16	K-6011	K-3031	K-0625M	K-0046	K-0302	1/2"
		18-24	K-6012	K-3031	K-0625M	K-0046	K-0302	1/2"
3/4"	19,05	10-12	K-6020	K-3041	K-0750M	K-0046	K-0302	5/8"
		13-16	K-6021	K-3041	K-0750M	K-0046	K-0302	5/8"
		18-24	K-6022	K-3041	K-0750M	K-0046	K-0302	5/8"
7/8"	22,23	10-12	K-6030	K-3046	K-0875M	K-0046	K-0302	5/8"
		13-16	K-6031	K-3046	K-0875M	K-0046	K-0302	5/8"
		18-24	K-6032	K-3046	K-0875M	K-0046	K-0302	5/8"
1"	25,4	10-12	K-6040	K-3051	K-1000M	K-0046	K-0302	3/4"
		13-16	K-6041	K-3051	K-1000M	K-0046	K-0302	3/4"
		18-24	K-6042	K-3051	K-1000M	K-0046	K-0302	3/4"

20 & 30 TON "SUPER-JENNY"

TUBE OD		TOOL	TUBE GAUGE	PULLING SPEAR	PULLING JAW	NOSE COLLAR	O-RING	JAW SPRING	SPEAR-MALE
[INCH]	[MM]								
5/8"	15,88	20 Ton 30 Ton	13-16	K-6011	K-3032	K-0625	K-0006	K-0303	1/2"
			18-24	K-6012	K-3032	K-0625	K-0006	K-0303	1/2"
3/4"	19,05		10-12	K-6020	K-3042	K-0750	K-0006	K-0303	5/8"
			13-16	K-6021	K-3042	K-0750	K-0006	K-0303	5/8"
			18-24	K-6022	K-3042	K-0750	K-0006	K-0303	5/8"
7/8"	22,23		10-12	K-6030	K-3047	K-0875	K-0006	K-0303	5/8"
			13-16	K-6031	K-3047	K-0875	K-0006	K-0303	5/8"
			18-24	K-6032	K-3047	K-0875	K-0006	K-0303	5/8"
1"	25,4		10-12	K-6040	K-3052	K-1000	K-0006	K-0303	3/4"
			13-16	K-6041	K-3052	K-1000	K-0006	K-0303	3/4"
			18-24	K-6042	K-3052	K-1000	K-0006	K-0303	3/4"
1-1/4"	31,75		10-12	K-6060	K-3072	K-1250	K-0006	K-0303	1"
		13-16	K-6061	K-3072	K-1250	K-0006	K-0303	1"	
		18-24	K-6062	K-3072	K-1250	K-0006	K-0303	1"	

RECOMMENDED PUMPS

Three pump choice with parameters of 700 bar (1000 psi) oil delivery at high pressure 0,9 to 1,1 l/min:

- ▶ electric 230 V standard type
- ▶ electric 230 V with oil cooler
- ▶ pneumatic 1,4 cu.m/min at 6 bar



60 TON "SUPER-JENNY"

TUBE OD		TUBE GAUGE	PULLING SPEAR	PULLING JAW	NOSE COLLAR	O-RING	JAW SPRING	SPEAR-MALE
[INCH]	[MM]							
1-1/2"	38,10	10-12	K-6070	K-3211	K-3212	K-0015	18.2321	1"
		13-16	K-6071	K-3211	K-3212	K-0015	18.2321	1"
		18-24	K-6072	K-3211	K-3212	K-0015	18.2321	1"
1-3/4"	44,45	10-12	K-6080	K-3216	K-3217	K-0015	18.2321	1"
		13-16	K-6081	K-3216	K-3217	K-0015	18.2321	1"
		18-24	K-6082	K-3216	K-3217	K-0015	18.2321	1"
2"	63,50	7-8	K-6090	K-3221	K-3222	K-0015	18.2321	1"
		10-12	K-6091	K-3221	K-3222	K-0015	18.2321	1"
		13-16	K-6092	K-3221	K-3222	K-0015	18.2321	1"

ACTP - Automatic, continuous tube pulling

The KRAIS ACTP is an automatic tube pulling system consists of a very fast pump and pulling gun. It is designed for continuous removal of tubes from boilers, condensers and heat exchangers.

Automation provides significant time savings compared to conventional systems. Tubes can be continuously pulled from between 16 mm (5/8") OD and 63 mm (2,5") OD. A choice of super heavy duty 17, 36 and 45 Ton pulling gun options are available.

The basic version ACTP is a fully hydraulic system - it guarantees safety and eliminates the need for electric wires between the pump and the gun. ACTP is also available with a choice of the electric or pneumatic drive for use in potentially explosive environments.

ADVANTAGES OF KRAIS ACTP

- ▶ tubes extraction takes place without damaging the tube sheet,
- ▶ hydraulic RAM ensures smooth and stable operation,
- ▶ automatic switching from low pressure to high depending on the RAM demand,
- ▶ high power translates into a short duration of the extraction cycle,
- ▶ the possibility of using different pulling guns with the same pump,
- ▶ compact design, short installation time and ease of use.



PULLING GUN	POWER	PULLING STROKE		PULLING SPEED		TUBE OD [MM]		TUBE OD [INCH]		WEIGHT
		[MM]	[INCH]	[M/MIN]	[INCH/MIN]	MIN	MAX	MIN	MAX	
ACTP-17	17 ton	150	6"	7	275	12,7	25,4	1/2"	1"	28 kg
ACTP-36	36 ton	150	6"	3,5	137	15,9	38,0	5/8"	1-1/2"	66 kg
ACTP-45	45 ton	100	4"	1,5	60	38,0	63,0	1-1/2"	2-1/2"	110 kg

PUMP CHOICE



ACTP is available with a choice of electric or pneumatic drive for use in potentially explosive environments.

EASY TO USE CONNECTORS



Pumps for ACTP are equipped with convenient meters and connectors with easy and convenient access. All parts are made with high attention to details.

ACTP - Automatic, continuous tube pulling



CONSUMABLES FOR ACPG-4 (4 TON)

TUBE OD		BWG	PULLING SPEAR	PULLING			HOLDING		
[INCH]	[MM]			JAWS	ORING	SPRING	JAWS	ORING	SPRING
5/8"	15,88	13-16	K-6011	K-3031		K-0302	K-3031		K-0302
		18-24	K-6012						
3/4"	19,05	10-12	K-6020	K-3041		K-0302	K-3041		K-0302
		13-16	K-6021						
		18-24	K-6022						
7/8"	22,23	10-12	K-6030	K-3046	O-34-3	K-0302	K-3046		K-0302
		13-16	K-6031						
		18-24	K-6032						
1"	25,4	10-12	K-6040	K-3051		K-0302	K-3051		K-0302
		13-16	K-6041						
		18-24	K-6042						

CONSUMABLES FOR ACPG-17 (17 TON)

TUBE OD		BWG	PULLING SPEAR	PULLING			HOLDING		
[INCH]	[MM]			JAWS	ORING	SPRING	JAWS	ORING	SPRING
5/8"	15,88	13-16	K-6011	K-3032		K-0302	K-3031		K-0303
		18-24	K-6012						
3/4"	19,05	10-12	K-6020	K-3042		K-0302	K-3041		K-0303
		13-16	K-6021						
		18-24	K-6022						
7/8"	22,23	10-12	K-6030	K-3047	O-44-3	K-0302	K-3046		K-0303
		13-16	K-6031						
		18-24	K-6032						
1"	25,4	10-12	K-6040	K-3052		K-0302	K-3051		K-0303
		13-16	K-6041						
		18-24	K-6042						



CONSUMABLES FOR ACPG-36 (36 TON)

TUBE OD		BWG	PULL SPEAR	PULLING			HOLDING		
[INCH]	[MM]			JAWS	ORING	SPRING	JAWS	ORING	SPRING
5/8"	15,88	13-16	K-6011	K-3030		K-0303	K-3032		K-0303
		18-24	K-6012						
3/4"	19,05	10-12	K-6020	K-3040		K-0303	K-3042		K-0303
		13-16	K-6021						
		18-24	K-6022						
7/8"	22,23	10-12	K-6030	K-3045		K-0303	K-3047		K-0303
		13-16	K-6031						
		18-24	K-6032						
1"	25,4	10-12	K-6040	K-3050	O-47-4	K-0303	K-3052		K-0303
		13-16	K-6041						
		18-24	K-6042						
1-1/4"	31,75	10-12	K-6060	K-3070		K-0303	K-3072		K-0303
		13-16	K-6061						
1-1/2"	38,10	10-12	K-6070	K-3090		K-0303	K-3092		K-0303
		13-16	K-6071						
		18-24	K-6072						

CONSUMABLES FOR ACPG-45 (45 TON)

TUBE OD		BWG	PULL SPEAR	PULLING			HOLDING		
[INCH]	[MM]			JAWS	ORING	SPRING	JAWS	ORING	SPRING
1-1/2"	38,10	10-12	K-6070	K-3210		K-2321	K-3211		K-2321
		13-16	K-6071						
		18-24	K-6072						
1-3/4"	44,45	10-12	K-6080	K-3215		K-2321	K-3216		K-2321
		13-16	K-6081						
2"	50,8	7-8	K-6090	K-3220	O-85-5	K-2321	K-3221	O-75-5	K-2321
		10-12	K-6091						
		13-16	K-6092						
2-1/4"	57,1	10-12	K-7000	K-3230		K-2321	K-3231		K-2321
		13-16	K-7001						
		18-24	K-7002						
2-1/2"	63,5	10-12	K-7010	K-3240		K-2321	K-3241		K-2321
		13-16	K-7011						
		18-24	K-7012						

HPR Tube Pullers



HPR-20 Tube Puller

HPR-20 is a heavy-duty, 20 Ton Pulling Ram. This tool has been engineered with a 6” pull stroke for challenging tube removal applications. It is fitted with a flush face, non-drip, couplings and its own custom suspension and handling bracket. In conjunction with Double Pull Adaptor, this machine has the captivity to pull the tubes from 1/2” to 1” from the tube sheet.

HPR-30 Tube Puller

HPR-30 is a heavy-duty, 30 Ton Pulling Ram. This tool has been engineered with a 6” pull stroke for challenging tube removal applications. It is fitted with a flush face, non-drip, couplings and its own custom suspension and handling bracket. In conjunction with Double Pull Adaptor, this machine has the captivity to pull the tube 9” from the tube sheet.

TUBE SPEARS FOR HPR20 & HPR-30 TUBE PULLERS

Length 8,750” (223 mm) with 7/8 flat size (hex), spear sizes of up to 3” on request

TUBE SPEARS FOR HPR-30 TUBE PULLERS

Only for HPR-30. Length 5,433” (138 mm) with 1-1/4 flat size (hex), spear sizes of up to 3” on request



TUBE SIZE			TOOL NO.	SMALL END DIAMETER		LARGE END DIAMETER	
[INCH]	[MM]	GA		[INCH]	[MM]	[INCH]	[MM]
1/2"	12,70	20	ATS-500-20	0,427	10,8	0,499	12,7
5/8"	15,88	12-13	ATS-625-12-13	0,402	10,2	0,610	15,5
		14-15	ATS-625-14-15	0,454	11,5	0,662	16,8
		16-17	ATS-625-16-17	0,489	12,4	0,625	15,9
		18-19	ATS-625-18-19	0,521	13,2	0,625	15,9
		20	ATS-625-20	0,545	13,8	0,620	15,7
		3/4"	19,05	10	ATS-750-10	0,454	11,5
11-13	ATS-750-11-13	0,505		12,8	0,713	18,1	
14-15	ATS-750-14-15	0,597		15,2	0,750	19,1	
16-17	ATS-750-16-17	0,614		15,6	0,750	19,1	
18-19	ATS-750-18-19	0,646		16,4	0,750	19,1	
20	ATS-750-20	0,670		17,0	0,745	18,9	
7/8"	22,23	14-15	ATS-875-14-15	0,699	17,8	0,875	22,2
16-18		ATS-875-16-18	0,740	18,8	0,948	24,1	
20		ATS-875-20	0,800	20,3	0,874	22,2	
1"	25,4	9-10	ATS-1 000-9-10	0,699	17,8	0,875	22,2
		11-13	ATS-1000-11-13	0,755	19,2	0,963	24,5
		12-13	ATS-1000-12-1 3	0,777	19,7	0,985	25,0
		14-15	ATS-1000-14-15	0,829	21,1	1,000	25,4
		16-17	ATS-1000-16-17	0,869	22,1	1,000	25,4
		18-20	ATS-1000-18-20	0,896	22,8	1,000	25,4

TUBE SIZE			TOOL NO.	SMALL END DIAMETER		LARGE END DIAMETER	
[INCH]	[MM]	GA		[INCH]	[MM]	[INCH]	[MM]
1-1/4"	31,75	7-8	ATS-1250-7-8	0,856	21,7	1,114	28,3
		10-11	ATS-1250-10-11	0,977	24,8	1,206	30,6
		12-13	ATS-1250-10-11	1,027	26,1	1,256	31,9
		14-15	ATS-1250-14-15	1,079	27,4	1,308	33,2
		16-18	ATS-1250-16-18	1,115	28,3	1,344	34,1
1-1/2"	38,10	10-11	ATS-1500-10-11	1,227	31,2	1,456	37,0
		12-13	ATS-1500-12-13	1,227	31,2	1,500	38,1
		14	ATS-1500-14	1,329	33,8	1,500	38,1

RECOMMENDED PUMPS

Three pump choice with parameters of 700 bar (1000 psi) oil delivery at high pressure 0,9 to 1,1 l/min.



► Electric, 230 V standard type



► Pneumatic 1,4 cu.m/min at 6 bar



► Electric, 230 V with oil cooler

HPR Tube Pullers

HPR Accesories

D-3055-7 RAM CHAIR



TUBE SIZE	TOOL NO
1-1/4"	D-3055-7
1-1/2"	D-3055-8
1-3/4"	D-3055-9
2"	D-3055-10
2-1/2"	D-3055-11

For tube sizes from 3/8" to 1" the following are required:

- ▶ Either Single or Double Pull Adaptor
- ▶ Tube Puffing Spear to suit
- ▶ Horse Shoe Lock Adaptor
- ▶ Load Cap

For tube sizes from 1-1/8" to 2-1/2" the following are required:

- ▶ Either Single or Double Pull Adaptor
- ▶ Tube Pulling Spear to suit
- ▶ Male x Male Adaptor
- ▶ Horse Shoe Lock Adaptor
- ▶ Ram Chair of Choice

NOTE!

M x F Adaptors are used when additional reach is required in 12" increments. An example of this is when pulling tubes close to shell, and having the puller operating 24" away from the Tube Sheet In this instance 2 each M x F Adaptors would be used in conjunction with either a single or double pull adaptor. For this example a strong back or extended ram chair would also be required.

D-3055-2 SINGLE PULL ADAPTOR



D-3055-3D DOUBLE ADAPTOR



D-3055-6 MALE X FEMALE ADAPTOR



D-3055-5 MALE X MALE ADAPTOR

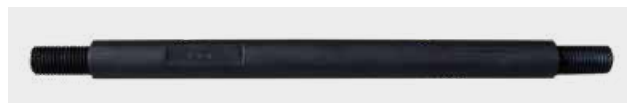

D-3055-4 HORSE SHOE LOCK



HPR-30 Setup for stubs 1 1/4" and up

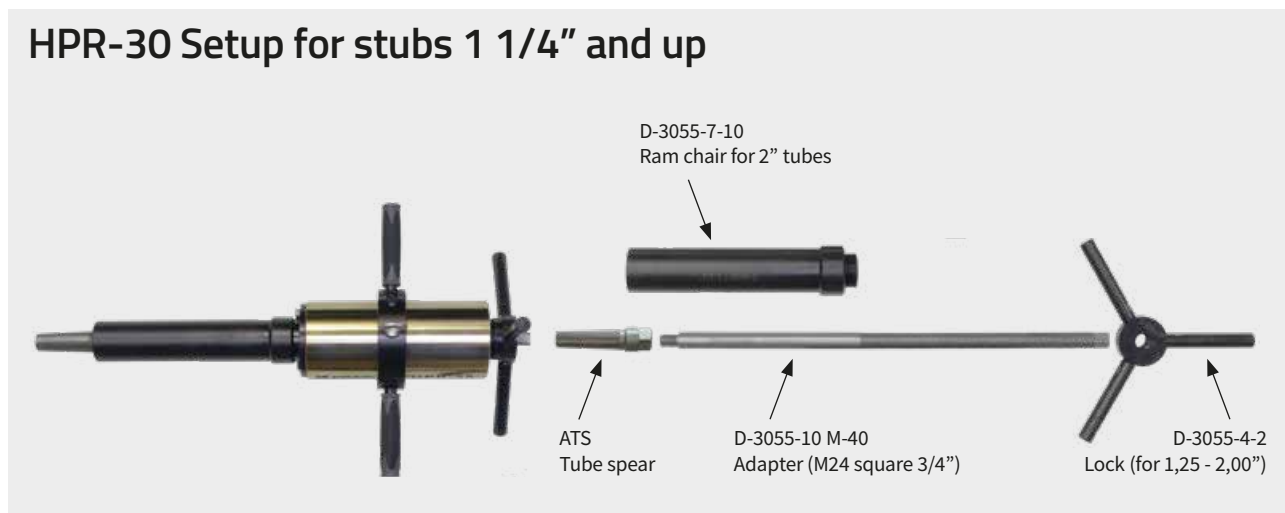

Tube SpinAIR

Pneumatic tube spinner is designed to remove and flatten non ferrous tubes from 5/8" to 1 1/4" OD. Can also be used to extract ferrous tubes from 5/8" to 1 1/2" OD using special shaped rolls sized to fit each tube.

SPINAIR FEATURES

- ▶ Pulling rolls are made from tool steel and hardened for extended life.
- ▶ High quality, strength construction body is made from aircraft grade aluminium and is anodized for high corrosion resistance.
- ▶ Nose piece and bearing caps are made from stainless steel for corrosion resistance
- ▶ Fully sealed bearings guarantee thousands of hours trouble free operation!

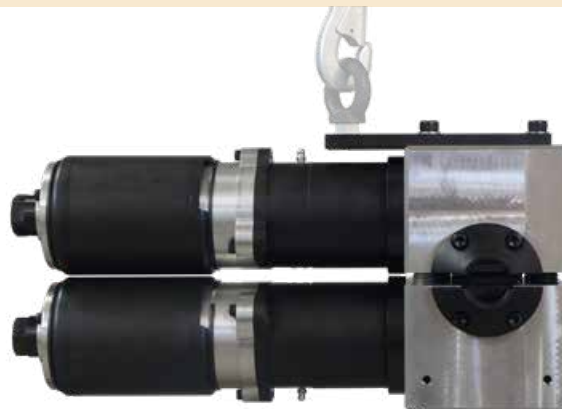

SELECTION GUIDE

	PULLING SPEED	TORQUE		PULLING FORCE	AIR CONSUMPTION		AIR PRESSURE		MAX MOTOR POWER
TUBE SPINAIR-12	12 m/min	1183 Nm	872,25 Ft.Lbs	2,50 Ton	2 x 2300 l/min	2 x 75 cfm	6,2 bar	90 psi	2 x 3,0 Hp
TUBE SPINAIR-20	20 m/min	886 Nm	653,48 Ft.Lbs	1,80 Ton	2 x 2300 l/min	2 x 75 cfm	6,2 bar	90 psi	2 x 3,0 Hp
TUBE SPINAIR-40	40 m/min	960 Nm	708,06 Ft.Lbs	1,95 Ton	2 x 2800 l/min	2 x 95 cfm	6,2 bar	90 psi	2 x 3,5 Hp

TUBE SPINAIR HYDRAULIC



Hydraulic tube spinner SpinAir H is designed to perform the same tasks as the pneumatic version.

SpinAir H specification

Pulling speed: up to 70 m per minute (depends on pump)
 Standard configuration: 1" non ferrous tubes
 Body construction: aircraft grade aluminium, tool steel stainless.
 Weight: 50 kg
 Size: 160 x 220 x 350 mm

Pump Requirements

Min: 40 l/min at 2000 psi (gives approximately 30 m/min);
 Max: 100 l/min at 2250 psi (gives approximately 70 m/min);
 Forward and reverse oil flow.

It is recommended that the pump should be controlled by pedant with a forward and reverse lever attached to the Tube Traveller head. Variable flow control preferred.

SPHERICAL ROLLS



Optional, spherical rolls for tubes bigger than GA16.

TUBE SPINAIR AT WORK

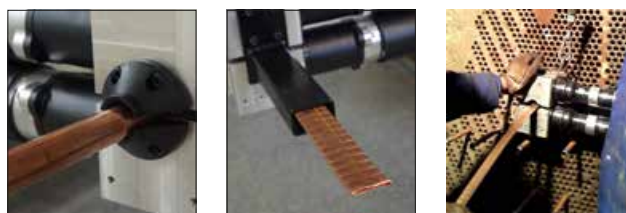

HYDRAULIC POWER PACK

For advanced, heavy-duty applications, we offer high-performance hydraulic power units—perfectly suited for operation with the Spin Air tube extraction and collapsing system.



Pumps

Three pump choice with parameters of 700 bar (1000 psi) oil delivery at high pressure 0,9 to 1,1 l/min



ELECTRIC 230 V WITH OIL COOLER



ELECTRIC 230 V STANDARD TYPE



PNEUMATIC 1,4 CU.M/MIN AT 6 BAR

PUPMS RECOMMENDATIONS

Above pumps are recommended for wide range of pullers



CP-1200



CP-1200-CC



CP-1200-FF



HPR20-CP-1000



HPR-CP2000



Super-Jenny



HPR 12 and HPR-30



Accessories

Accessories

PARALLEL GEAR DRIVE

L=235 W=33 H=70 MM

For use inside the header boxes where hand holes are not in line with tube centerline.

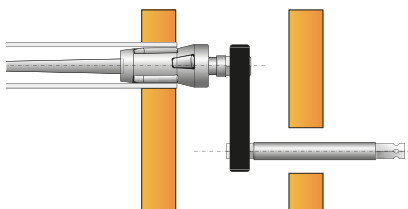
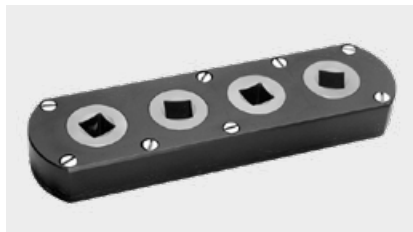

SQUARE DRIVE		TOOL
[INCH]	[MM]	
1/2" x 1/2"	12,7 x 12,7	P-Drive-127
3/4" x 3/4"	19,0 x 19,0	P-Drive-190
1" x 1"	25,4 x 25,4	P-Drive-254

RIGHT ANGLE GEAR DRIVE

L=292 W=45 H=98 MM

For use inside header boxes where handholds are at right angle to the tube centerline. For hand and power use.

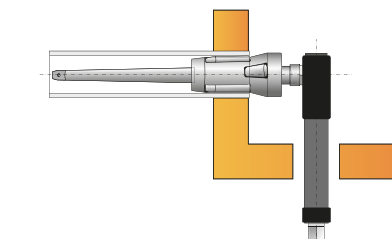

SQUARE DRIVE		TOOL
[INCH]	[MM]	
1/2" x 1/2"	12,7 x 12,7	RA-Drive-127
3/4" x 3/4"	19 x 19	RA-Drive-190
3/4" x 1"	19 x 25,4	RA-Drive-254

DOUBLE UNIVERSAL JOINT

Double Universal Joint and Double Universal Joint with Quick Change Chuck.

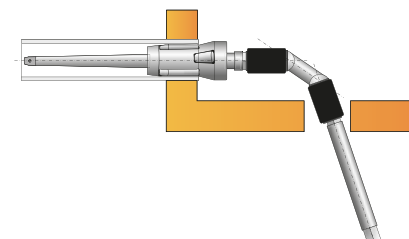

SQUARE DRIVE	TOOL	CHUCK
3/8"	DUJ-3/8	-
	DUJ-3/8-QCC	QCC
1/2"	DUJ-1/2	-
	DUJ-1/2-QCC	QCC
3/4"	DUJ-3/4	FxF
1"	DUJ-1	FxF

EXTENSIONS

Extensions and extensions with Quick Change Chuck (QCC), single and double.

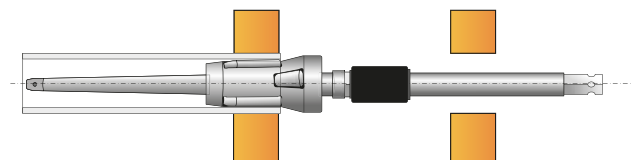

SQUARE DRIVE [INCH]	TOOL	LENGTHS		QCC
		[INCH]	[MM]	
3/8"	Ext-3/8	8; 12; 24; 36	200; 300; 600; 900	-
	Ext-3/8-QCC	8; 12; 24; 36	200; 300; 600; 900	1
	Ext-3/8-2QCC	8; 12; 24; 36	200; 300; 600; 900	2
1/2"	Ext-1/2	8; 12; 24; 36	200; 300; 600; 900	-
	Ext-1/2-QCC	8; 12; 24; 36	200; 300; 600; 900	1
	Ext-1/2-2QCC	8; 12; 24; 36	200; 300; 600; 900	2
3/4"	Ext-3/4	8; 12; 24; 36	200; 300; 600; 900	-
1"	Ext-1	8; 12; 24; 36	200; 300; 600; 900	-

SINGLE UNIVERSAL JOINT

Single Universal Joint and Single Universal joint with Quick Change Chuck (QCC).

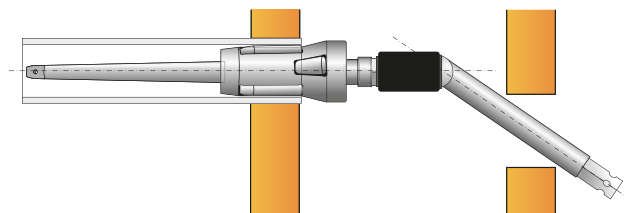

SQUARE [INCH]	TOOL	AVAILABLE LENGTHS		QCC
		[INCH]	[MM]	
3/8	SUJ-3/8	8; 12; 24; 36	200; 300; 600; 900	-
	SUJ-3/8-QCC	8; 12; 24; 36	200; 300; 600; 900	+
1/2	SUJ-1/2	8; 12; 24; 36	200; 300; 600; 900	-
	SUJ-1/2-QCC	8; 12; 24; 36	200; 300; 600; 900	+
3/4	SUJ-3/4	8; 12; 24	200; 300; 600	-
1	SUJ-1	8; 12; 24	200; 300; 600	-

Accesories

TUBE GUIDE

The Tube Guide consist of a steel or aluminium or plastic tapered head and an replaceable nylon brush, and it's used to guide tubes through the sheets and the tube support plates during tube bundles assembling. The nylon brush fits in the tube end, holding pilot firmly in place.

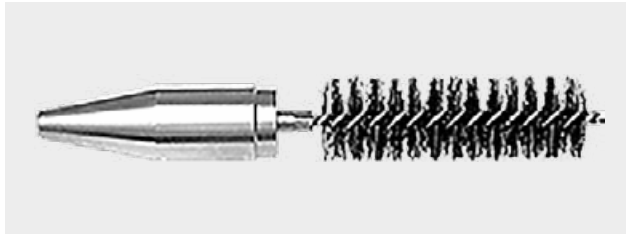

TUBE OD		TUBE GAUGE	TUBE GUIDE
[INCH]	[MM]		
1/2	12,7	16-18	TG-1
		19-20	TG-2
		21-23	TG-3
5/8	15,88	12-13	TG-4
		14-16	TG-5
		17-20	TG-6
		22-24	TG-7
3/4	19,05	10-12	TG-8
		13-16	TG-9
		17-20	TG-10
		21-22	TG-11
7/8	22,2	10-12	TG-12
		13-16	TG-13
		17-20	TG-14
1	25,4	22-24	TG-15
		8-9	TG-16
		10-12	TG-17
		13-16	TG-18
1-1/4	31,7	17-20	TG-19
		21-23	TG-20
		15.	TG-21
1-1/2	38,1	16-	TG-22
		15.	TG-23
		16-	TG-24

MOTOR COUPLING

Motor coupling and Motor coupling with Quick Change Chuck (QCC)



SQUARE	TOOL	LENGTH	QCC
3/8	MT-2x3/8"	2"	
	MT-2x3/8"-QCC	2"	YES
1/2	MT-2x1/2	2"	
	MT-2x1/2"-QCC	2"	YES
3/8	MT-2x3/8"	2"	
1/2	MT-3x1/2"	3"	
3/4	MT-3x3/4"	3"	
1	MT-4x1"	4"	

URH-1925 UNIVERSAL RATCHET HANDLE

Manual drive for tube expanders. One side 3/4" square drive, other side 1" square drive. Allows rotation transmitted by a ratched mechanism.



Testing pumps

All testing pumps are delivered „ready for use“ and equipped with:

- ▶ tank (Except PEM 30),
- ▶ pressure gauge,
- ▶ drain valve,
- ▶ flexible hose. 16" long. (3" for PEM 30 / 6" for PEM 40)

The seals used are made for usage with water, fluid oil or gas-oil.
Please call us any other liquids.

PEM HAND OPERATED PUMP



LE-PTP ELECTRIC PUMP



PTP1201 PNEUMATIC PUMP



MODEL	DRIVEN	SERVICE PRESSURE		DIAMETER	STROKE	VOLUME PER STROKE		TANK CAPACITY		WEIGHT	
		BAR	PSI	MM	MM	CM ³	IN ³	LITRES	U.S.G	KG	LBS
PEM 30	Hand	30	400	14	400	61	3,7	-	-	4,2	9,3
PEM 40		60	850	20	34	10	0,6	14	3,7	6,3	14
PEM 50		50	700	30	40	28	1,7	45	11,9	13	29
PEM 100		100	1400	22	40	15	0,9	45	11,9	13	29
PEM 200		200	2800	50x16	40	78x8	48x0,5	45	11,9	18	40
PEM 600		600	8500	32x12	40	32x4	2x0,25	60	15,9	35	77,8
PEM 1000		1000	14000	32x8	40	32x2	2x0,12	60	15,9	35	77,8
LE-PTP 180	ELECTIRC	180	2548	-	-	-	-	100	26,45	60	132,3
PTP 1201	PNEUMATIC	720*	10200*	-	-	-	-	10	2,64	21	46,3

* depends on air pressure



Useful charts

THICKNESS OF WALL IN BIRMINGHAM WIRE GAGE AND IN DECIMAL INCHES

TUBE		20	19	18	17	16	15	14	13	12	11	10	9	8	7	6	5	4	3	2	1	0
O.D.	I.D.	.035	.042	.049	.058	.065	.072	.083	.095	.109	.120	.134	.148	.165	.180	.203	.220	.238	.259	.284	.300	.340
1/2	Min.	.422	.408	.392	.373	.357	.342	.318	.291	.260	.236											
	Nom.	.430	.416	.402	.384	.370	.356	.334	.310	.282	.260											
5/8	Min.	.547	.533	.517	.498	.482	.467	.443	.417	.385	.361	.330	.299	.262	.229							
	Nom.	.555	.541	.527	.509	.495	.481	.459	.435	.407	.385	.357	.329	.295	.265							
3/4	Min.	.672	.658	.642	.623	.607	.592	.568	.542	.510	.486	.455	.424	.387	.354	.303	.266	.226	.180			
	Nom.	.680	.666	.652	.634	.620	.606	.584	.560	.532	.510	.482	.454	.420	.390	.344	.310	.274	.232			
7/8	Min.	.797	.783	.767	.747	.732	.717	.693	.666	.636	.611	.580	.549	.512	.479	.428	.391	.351	.305			
	Nom.	.805	.791	.777	.759	.745	.731	.709	.685	.657	.635	.607	.579	.545	.515	.469	.435	.399	.357			
1	Min.	.922	.908	.892	.873	.857	.842	.818	.791	.761	.736	.706	.675	.637	.604	.553	.516	.476	.430	.375	.340	.252
	Nom.	.930	.916	.902	.884	.870	.856	.834	.810	.782	.760	.732	.704	.670	.640	.594	.560	.524	.482	.432	.400	.320
1-1/8	Min.	1.047	1.033	1.017	.997	.982	.967	.943	.916	.886	.861	.831	.800	.762	.729	.678	.641	.601	.555	.500	.465	.377
	Nom.	1.055	1.041	1.027	1.009	.995	.981	.959	.935	.907	.885	.857	.829	.795	.765	.719	.685	.649	.607	.557	.525	.445
1-1/4	Min.	1.172	1.158	1.142	1.122	1.107	1.092	1.068	1.041	1.011	.986	.956	.925	.887	.854	.803	.766	.726	.680	.625	.590	.502
	Nom.	1.180	1.166	1.152	1.134	1.120	1.106	1.084	1.060	1.032	.1010	.982	.954	.920	.890	.844	.810	.774	.732	.682	.650	.570
1-3/8	Min.	1.297	1.283	1.267	1.247	1.232	1.217	1.192	1.166	1.136	.111	1.081	.049	1.012	.979	.928	.891	.851	.805	.750	.715	.627
	Nom.	1.305	1.291	1.277	1.259	1.245	1.231	1.209	1.185	1.157	1.135	1.107	.079	1.045	1.015	.969	.935	.899	.857	.807	.775	.695
1-1/2	Min.	1.422	1.408	1.392	1.372	1.357	1.342	1.318	1.291	1.260	1.236	1.205	1.174	1.137	1.104	1.053	1.016	.976	.930	.875	.840	.752
	Nom.	1.430	1.426	1.402	1.384	1.370	1.356	1.334	1.310	1.282	1.260	1.232	1.204	1.170	1.140	1.094	1.060	1.024	.982	.932	.900	.820
1-3/4	Min.	1.672	1.658	1.642	1.622	1.607	1.592	1.568	1.541	1.510	1.486	1.455	1.424	1.387	1.354	1.303	1.266	1.226	1.180	1.125	1.090	1.002
	Nom.	1.680	1.666	1.652	1.634	1.620	1.606	1.584	1.560	1.532	1.510	1.482	1.454	1.420	1.390	1.344	1.310	1.274	1.232	1.182	1.150	1.070
2	Min.	1.922	1.908	1.892	1.872	1.857	1.842	1.817	1.791	1.760	1.736	1.705	1.674	1.637	1.604	1.553	1.516	1.476	1.430	1.375	1.340	1.252
	Nom.	1.930	1.916	1.902	1.884	1.870	1.856	1.834	1.810	1.782	1.760	1.732	1.704	1.670	1.640	1.594	1.560	1.524	1.482	1.432	1.400	1.320
2-1/4	Min.	2.172	2.158	2.142	2.122	2.107	2.092	2.067	2.041	2.010	1.986	1.955	1.924	1.887	1.854	1.803	1.766	1.726	1.680	1.625	1.590	1.502
	Nom.	2.180	2.166	2.152	2.134	2.120	2.106	2.084	2.060	2.032	2.010	1.982	1.954	1.920	1.890	1.844	1.810	1.774	1.732	1.682	1.650	1.570
2-1/2	Min.	2.422	2.408	2.392	2.372	2.357	2.342	2.317	2.291	2.260	2.236	2.205	2.174	2.137	2.104	2.053	2.016	1.976	1.930	1.875	1.840	1.752
	Nom.	2.430	2.416	2.402	2.384	2.370	2.356	2.334	2.310	2.282	2.260	2.232	2.204	2.170	2.140	2.094	2.060	2.024	1.982	1.932	1.900	1.820
2-3/4	Min.	2.672	2.658	2.642	2.622	2.607	2.592	2.567	2.541	2.510	2.486	2.455	2.424	2.387	2.354	2.303	2.266	2.226	2.180	2.125	2.090	2.002
	Nom.	2.680	2.666	2.652	2.634	2.620	2.606	2.584	2.560	2.532	2.510	2.482	2.454	2.420	2.390	2.344	2.310	2.274	2.232	2.182	2.150	2.070
3	Min.	2.922	2.908	2.892	2.872	2.857	2.842	2.817	2.791	2.760	2.736	2.705	2.674	2.637	2.604	2.553	2.516	2.476	2.430	2.375	2.340	2.252
	Nom.	2.930	2.916	2.902	2.884	2.870	2.856	2.834	2.810	2.782	2.760	2.732	2.704	2.670	2.640	2.594	2.560	2.524	2.482	2.432	2.400	2.320
3-1/4	Min.	3.172	3.158	3.142	3.122	3.107	3.092	3.067	3.041	3.010	2.986	2.955	2.924	2.887	2.854	2.803	2.766	2.726	2.680	2.625	2.590	2.502
	Nom.	3.180	3.166	3.152	3.134	3.120	3.106	3.084	3.060	3.032	3.010	2.982	2.954	2.920	2.890	2.844	2.810	2.774	2.732	2.682	2.650	2.570
3-1/2	Min.	3.422	3.408	3.392	3.372	3.357	3.342	3.317	3.291	3.260	3.236	3.205	3.174	3.137	3.104	3.053	3.016	2.976	2.930	2.875	2.840	2.752
	Nom.	3.430	3.416	3.402	3.384	3.370	3.356	3.334	3.310	3.282	3.260	3.232	3.204	3.170	3.140	3.094	3.060	3.024	2.982	2.932	2.900	2.820
3-3/4	Min.	3.672	3.658	3.642	3.622	3.607	3.592	3.567	3.541	3.510	3.486	3.455	3.424	3.387	3.354	3.303	3.266	3.226	3.180	3.125	3.090	3.002
	Nom.	3.680	3.666	3.652	3.634	3.620	3.606	3.584	3.560	3.532	3.510	3.482	3.454	3.420	3.390	3.344	3.310	3.274	3.232	3.182	3.150	3.070
4	Min.	3.922	3.908	3.892	3.872	3.857	3.842	3.817	3.791	3.760	3.736	3.705	3.674	3.637	3.604	3.553	3.516	3.476	3.430	3.375	3.340	3.252
	Nom.	3.930	3.916	3.902	3.884	3.870	3.856	3.834	3.810	3.782	3.760	3.732	3.704	3.670	3.640	3.594	3.560	3.524	3.482	3.432	3.400	3.320
4-1/2	Min.	4.422	4.408	4.392	4.372	4.357	4.342	4.317	4.291	4.260	4.236	4.205	4.174	4.137	4.104	4.053	4.016	3.976	3.930	3.875	3.840	3.752
	Nom.	4.430	4.416	4.402	4.384	4.370	4.356	4.334	4.310	4.282	4.260	4.232	4.204	4.170	4.140	4.094	4.060	4.024	3.982	3.932	3.900	3.820
5	Min.	4.922	4.908	4.892	4.872	4.857	4.842	4.817	4.791	4.760	4.736	4.705	4.674	4.637	4.604	4.553	4.516	4.476	4.430	4.375	4.340	4.252
	Nom.	4.930	4.916	4.902	4.884	4.870	4.856	4.834	4.810	4.782	4.760	4.732	4.704	4.670	4.640	4.594	4.560	4.524	4.482	4.432	4.400	4.320

ADDITIONAL BIRMINGHAM WIRE GAGES

NUMBER	36	35	34	33	32	31	30	29	28	27	26	25	24	23	22	21	00	000	0000	00000
DECIMAL	.004	.005	.007	.008	.009	.010	.012	.013	.014	.016	.018	.020	.022	.025	.028	.032	.380	.425	.454	.500

THICKNESS OF WALL IN BIRMINGHAM WIRE GAGE IN MILLIMETERS

TUBE	20	19	18	17	16	15	14	13	12	11	10	9	8	7	6	5	4	3	2	1	0	
O.D.	I.D.	.9	1.1	1.2	1.5	1.7	1.8	2.1	2.4	2.8	3.0	3.4	3.8	4.2	4.6	5.2	5.6	6.0	6.6	7.2	7.6	8.6
127	Min.	10.7	10.4	10.0	9.5	9.1	8.7	8.1	7.4	6.6	6.0											
	Nom.	10.9	10.6	10.2	9.8	9.4	9.0	8.5	7.9	7.2	6.6											
159	Min.	13.9	13.5	13.1	12.6	12.2	11.9	11.3	10.6	9.8	9.2	8.4	7.6	6.7	5.8							
	Nom.	14.1	13.7	13.4	12.9	12.6	12.2	11.7	11.0	10.3	9.8	9.1	8.4	7.5	6.7							
191	Min.	17.1	16.7	16.3	15.8	15.4	15.0	14.4	13.8	13.0	12.3	11.6	10.8	9.8	9.0	7.7	6.8	5.7	4.6			
	Nom.	17.3	16.9	16.6	16.1	15.7	15.4	14.8	14.2	13.5	13.0	12.2	11.5	10.7	9.9	8.7	7.9	7.0	5.9			
222	Min.	20.2	19.9	19.5	19.0	18.6	18.2	17.6	16.9	16.2	15.5	14.7	13.9	13.0	12.2	10.9	9.9	8.9	7.7			
	Nom.	20.4	20.1	19.7	19.3	18.9	18.6	18.0	17.4	16.7	16.1	15.4	14.7	13.8	13.1	11.9	11.0	10.1	9.1			
254	Min.	23.4	23.1	22.7	22.2	21.8	21.4	20.8	20.1	19.3	18.7	17.9	17.1	16.2	15.3	14.0	13.1	12.1	10.9	9.5	8.6	6.4
	Nom.	23.6	23.3	22.9	22.5	22.1	21.7	21.2	20.6	19.9	19.3	18.6	17.9	17.0	16.3	15.1	14.2	13.3	12.2	11.0	10.2	8.1
286	Min.	26.6	26.2	25.8	25.3	24.9	24.6	24.0	23.3	22.5	21.9	21.1	20.3	19.4	18.5	17.2	16.3	15.3	14.1	12.7	11.8	9.6
	Nom.	26.8	26.4	26.1	25.6	25.3	24.9	24.4	23.7	23.0	22.5	21.8	21.1	20.2	19.4	18.3	17.4	16.5	15.4	14.1	13.3	11.3
318	Min.	29.8	29.4	29.0	28.5	28.1	27.7	27.1	26.4	25.7	25.0	24.3	23.5	22.5	21.7	20.4	19.5	18.4	17.3	15.9	15.0	12.8
	Nom.	30.0	29.6	29.3	28.8	28.4	28.1	27.5	26.9	26.2	25.7	24.9	24.2	23.4	22.6	21.4	20.6	19.7	18.6	17.3	16.5	14.5
349	Min.	32.9	32.6	32.2	31.7	31.3	30.9	30.3	29.6	28.9	28.2	27.5	26.6	25.7	24.9	23.6	22.6	21.6	20.4	19.1	18.2	15.9
	Nom.	33.1	32.8	32.4	32.0	31.6	31.3	30.7	30.1	29.4	28.8	28.1	27.4	26.5	25.8	24.6	23.7	22.8	21.8	20.5	19.7	17.7
381	Min.	36.1	35.8	35.4	34.8	34.5	34.1	33.5	32.8	32.0	31.4	30.6	29.8	28.9	28.0	26.7	25.8	24.8	23.6	22.2	21.3	19.1
	Nom.	36.3	36.2	35.6	35.2	34.8	34.4	33.9	33.3	32.6	32.0	31.3	30.6	29.7	29.0	27.8	26.9	26.0	24.9	23.7	22.9	20.8
44.5	Min.	42.5	42.1	41.7	41.2	40.8	40.4	39.8	39.1	38.4	37.7	37.0	36.2	35.2	34.4	33.1	32.2	31.1	30.0	28.6	27.7	25.5
	Nom.	42.7	42.3	42.0	41.5	41.1	40.8	40.2	39.6	38.9	38.4	37.6	36.9	36.1	35.3	34.1	33.3	32.4	31.3	30.0	29.2	27.2
50.8	Min.	48.8	48.5	48.1	47.5	47.2	46.8	46.2	45.5	44.7	44.1	43.3	42.5	41.6	40.7	39.4	38.5	37.5	36.3	34.9	34.0	31.8
	Nom.	49.0	48.7	48.3	47.9	47.5	47.1	46.6	46.0	45.3	44.7	44.0	43.3	42.4	41.7	40.5	39.6	38.7	37.6	36.4	35.6	33.5
57.2	Min.	55.2	54.8	54.4	53.9	53.5	53.1	52.5	51.8	51.1	50.4	49.7	48.9	47.9	47.1	45.8	44.9	43.8	42.7	41.3	40.4	38.2
	Nom.	55.4	55.0	54.7	54.2	53.8	53.5	52.9	52.3	51.6	51.1	50.3	49.6	48.8	48.0	46.8	46.0	45.1	44.0	42.7	41.9	39.9
63.5	Min.	61.5	61.2	60.8	60.2	59.9	59.5	58.9	58.2	57.4	56.8	56.0	55.2	54.3	53.4	52.1	51.2	50.2	49.0	47.6	46.7	44.5
	Nom.	61.7	61.4	61.0	60.6	60.2	59.8	59.3	58.7	58.0	57.4	56.7	56.0	55.1	54.4	53.2	52.3	51.4	50.3	49.1	48.3	46.2
69.9	Min.	67.9	67.5	67.1	66.6	66.2	65.8	65.2	64.5	63.8	63.1	62.4	61.6	60.6	59.8	58.5	57.6	56.5	55.4	54.0	53.1	50.9
	Nom.	68.1	67.7	67.4	66.9	66.5	66.2	65.6	65.0	64.3	63.8	63.0	62.3	61.5	60.7	59.5	58.7	57.8	56.7	55.4	54.6	52.6
76.2	Min.	74.2	73.9	73.5	72.9	72.6	72.2	71.6	70.9	70.1	69.5	68.7	67.9	67.0	66.1	64.8	63.9	62.9	61.7	60.3	59.4	57.2
	Nom.	74.4	74.1	73.7	73.3	72.9	72.5	72.0	71.4	70.7	70.1	69.4	68.7	67.8	67.1	65.9	65.0	64.1	63.0	61.8	61.0	58.9
82.6	Min.	80.6	80.2	79.8	79.3	78.9	78.5	77.9	77.2	76.5	75.8	75.1	74.3	73.3	72.5	71.2	70.3	69.2	68.1	66.7	65.8	63.6
	Nom.	80.8	80.4	80.1	79.6	79.2	78.9	78.3	77.7	77.0	76.5	75.7	75.0	74.2	73.4	72.2	71.4	70.5	69.4	68.1	67.3	65.3
88.9	Min.	86.9	86.6	86.2	85.6	85.3	84.9	84.3	83.6	82.8	82.2	81.4	80.6	79.7	78.8	77.5	76.6	75.6	74.4	73.0	72.1	69.9
	Nom.	87.1	86.8	86.4	86.0	85.6	85.2	84.7	84.1	83.4	82.8	82.1	81.4	80.5	79.8	78.6	77.7	76.8	75.7	74.5	73.7	71.6
95.3	Min.	93.3	92.9	92.5	92.0	91.6	91.2	90.6	89.9	89.2	88.5	87.8	87.0	86.0	85.2	83.9	83.0	81.9	80.8	79.4	78.5	76.3
	Nom.	93.5	93.1	92.8	92.3	91.9	91.6	91.0	90.4	89.7	89.2	88.4	87.7	86.9	86.1	84.9	84.1	83.2	82.1	80.8	80.0	78.0
101.6	Min.	99.6	99.3	98.9	98.3	98.0	97.6	97.0	96.3	95.5	94.9	94.1	93.3	92.4	91.5	90.2	89.3	88.3	87.1	85.7	84.8	82.6
	Nom.	99.8	99.5	99.1	98.7	98.3	97.9	97.4	96.8	96.1	95.5	94.8	94.1	93.2	92.5	91.3	90.4	89.5	88.4	87.2	86.4	84.3
114.3	Min.	112.3	112.0	111.6	111.0	110.7	110.3	109.7	109.0	108.2	107.6	106.8	106.0	105.1	104.2	102.9	102.0	101.0	99.8	98.4	97.5	95.3
	Nom.	112.5	112.2	111.8	111.4	111.0	110.6	110.1	109.5	108.8	108.2	107.5	106.8	105.9	105.2	104.0	103.1	102.2	101.1	99.9	99.1	97.0
127.3	Min.	125.0	124.7	124.3	123.7	123.4	123.0	122.4	121.7	120.9	120.3	119.5	118.7	117.8	116.9	115.6	114.7	113.7	112.5	111.1	110.2	108.0
	Nom.	125.2	124.9	124.5	124.1	123.7	123.3	122.8	122.2	121.5	120.9	120.2	119.5	118.6	117.9	116.7	115.8	114.9	113.8	112.6	111.8	109.7

ADDITIONAL BIRMINGHAM WIRE GAGES

NUMBER	36	35	34	33	32	31	30	29	28	27	26	25	24	23	22	21	00	000	0000	00000
MM	.1	.1	.2	.2	.2	.3	.3	.3	.4	.4	.5	.5	.6	.6	.7	.8	9.7	10.8	11.5	12.7

Pipe Chart [inch]

SIZE	OUTER DIAMETER		SCHEDULE 5	SCHEDULE 10	SCHEDULE 20	SCHEDULE 30	SCHEDULE 40	STANDARD	SCHEDULE 60	SCHEDULE 80	X-HEAVY	SCHEDULE 100	SCHEDULE 120	SCHEDULE 140	SCHEDULE 160	XX-HEAVY
1/8	0,405	Wall thickness	0,035	0,049			0,068	0,068		0,095	0,095					
		Inside diameter	0,335				0,269	0,269		0,215	0,215					
1/4	0,540	Wall thickness	0,049	0,065			0,088	0,088		0,119	0,119					
		Inside diameter	0,442	0,410			0,364	0,364		0,302	0,302					
3/8	0,675	Wall thickness	0,049	0,065			0,091	0,091		0,126	0,126					
		Inside diameter	0,577	0,545			0,493	0,493		0,423	0,423					
1/2	0,840	Wall thickness	0,065	0,083			0,109	0,109		0,147	0,147				0,187	0,294
		Inside diameter	0,710	0,674			0,622	0,622		0,546	0,546				0,466	0,442
3/4	1,050	Wall thickness	0,065	0,083			0,113	0,113		0,154	0,154				0,218	0,308
		Inside diameter	0,920	0,884			0,824	0,824		0,742	0,742				0,614	0,434
1	1,315	Wall thickness	0,065	0,190			0,133	0,133		0,179	0,179				0,250	0,358
		Inside diameter	1,185	0,935			1,049	1,049		0,957	0,957				0,815	0,599
1 1/4	1,660	Wall thickness	0,065	0,109			0,140	0,140		0,191	0,191				0,250	0,382
		Inside diameter	1,530	1,442			1,380	1,380		1,278	1,278				1,160	0,896
1 1/2	1,900	Wall thickness	0,065	0,109			0,145	0,145		0,200	0,200				0,281	0,400
		Inside diameter	1,770	1,682			1,610	1,610		1,500	1,500				1,338	1,100
2	2,375	Wall thickness	0,065	0,109			0,154	0,154		0,218	0,218				0,343	0,436
		Inside diameter	2,245	2,157			2,067	2,067		1,939	1,939				1,689	1,503
2 1/2	2,875	Wall thickness	0,083	0,120			0,203	0,203		0,276	0,276				0,375	0,552
		Inside diameter	2,709	2,635			2,469	2,469		2,323	2,323				2,125	1,771
3	3,500	Wall thickness	0,083	0,120			0,216	0,216		0,300	0,300				0,437	0,600
		Inside diameter	3,334	3,260			3,068	3,068		2,900	2,900				2,626	2,300
3 1/2	4,000	Wall thickness	0,083	0,120			0,226	0,226		0,318	0,318					0,636
		Inside diameter	3,834	3,760			3,548	3,548		3,364	3,364					2,728
4	4,500	Wall thickness	0,083	0,120			0,237	0,237	0,281	0,337	0,337		0,437		0,531	0,674
		Inside diameter	4,334	4,260			4,026	4,026	3,938	3,826	3,826		3,626		3,438	3,152
4 1/2	5,000	Wall thickness						0,247			0,355					0,710
		Inside diameter						4,506			4,290					3,580
5	5,563	Wall thickness	0,109	0,134			0,258	0,258		0,375	0,375		0,500		0,625	0,750
		Inside diameter	5,345	5,295			5,047	5,047		4,813	4,813				4,313	4,063
6	6,625	Wall thickness	0,109	0,134			0,280	0,280		0,432	0,432		0,562		0,718	0,864
		Inside diameter	6,407	6,357			6,065	6,065		5,761	5,761				5,189	4,897
7	7,625	Wall thickness						0,301			0,500					0,875
		Inside diameter						7,023			6,625					5,875
8	8,625	Wall thickness	0,109	0,148	0,250	0,277	0,322	0,322	0,406	0,500	0,500	0,593	0,718	0,812	0,906	0,875
		Inside diameter	8,407	8,329	8,125	8,071	7,981	7,981	7,813	7,625	7,625	7,439	7,189	7,001	6,813	6,875
9	9,625	Wall thickness						0,342			0,500					
		Inside diameter						8,941			8,625					
10	10,750	Wall thickness	0,134	0,165	0,250	0,307	0,365	0,365	0,500	0,593	0,500	0,718	0,843	1,000	1,125	
		Inside diameter	10,482	10,420	10,250	10,136	10,020	10,020	9,750	9,564	9,750	9,314	9,064	8,750	8,500	
11	11,750	Wall thickness						0,375			0,500					
		Inside diameter						11,000			10,750					
12	12,750	Wall thickness	0,156	0,180	0,250	0,330	0,406	0,375	0,562	0,687	0,500	0,843	1,000	1,125	1,312	
		Inside diameter	12,438	12,390	12,250	12,090	11,938	12,000	11,626	11,376	11,750	11,064	10,750	10,500	10,126	
14	14,000	Wall thickness	0,156	0,250	0,312	0,375	0,437	0,375	0,593	0,750	0,500	0,937	1,0930	1,250	1,406	
		Inside diameter	13,688	13,500	13,376	13,250	13,126	13,250	12,814	12,500	13,000	12,126	-7,860	11,500	11,188	
16	16,000	Wall thickness	0,165	0,250	0,312	0,375	0,500	0,375	0,656	0,843	0,500	1,031	1,218	1,437	1,593	
		Inside diameter	15,670	15,500	15,376	15,250	15,000	15,250	14,688	14,314	15,000	13,938	13,564	13,126	12,814	
18	18,000	Wall thickness	0,165	0,250	0,312	0,437	0,562	0,375	0,750	0,937	0,500	1,156	1,375	1,562	1,781	
		Inside diameter	17,670	17,500	17,376	17,126	16,876	17,250	16,500	16,126	17,000	15,688	15,250	14,876	14,438	
20	20,000	Wall thickness	0,188	0,250	0,375	0,500	0,593	0,375	0,812	1,031	0,500	1,280	1,500	1,750	1,968	
		Inside diameter	19,624	19,500	19,250	19,000	18,814	19,250	18,376	17,938	19,000	17,440	17,000	16,500	16,064	
24	24,000	Wall thickness	0,218	0,250	0,375	0,562	0,687	0,375	0,968	1,218	0,500	1,531	1,812	2,062	2,343	
		Inside diameter	23,564	23,500	23,250	22,876	22,626	23,250	22,064	21,564	23,000	20,938	20,376	19,876	19,314	
26	26,000	Wall thickness		0,312	0,500			0,375			0,500					
		Inside diameter		25,376	25,000			25,250			25,000					
28	28,000	Wall thickness		0,312	0,500	0,625		0,375			0,500					
		Inside diameter		27,376	27,000	26,750		27,250			27,000					
30	30,000	Wall thickness	0,250	0,312	0,500	0,625		0,375			0,500					
		Inside diameter	29,500	29,376	29,000	28,750		29,250			29,000					
32	32,000	Wall thickness		0,312	0,500	0,625	0,688	0,375			0,500					
		Inside diameter		31,376	31,000	30,750	30,624	31,250			31,000					
34	34,000	Wall thickness		0,344	0,500	0,625	0,688	0,375			0,500					
		Inside diameter		33,312	33,000	32,750	32,624	33,250								
36	36,000	Wall thickness		0,312	0,500	0,625	0,750	0,375			0,500					
		Inside diameter		35,376	35,000	34,750	34,500	35,250			35,000					
42	42,000	Wall thickness						0,375			0,500					
		Inside diameter						41,250			41,000					
48	48,000	Wall thickness						0,375			0,500					
		Inside diameter						47,250			47,000					

Pipe Chart [mm]

SIZE	OUTER DIAMETER		SCHEDULE 5	SCHEDULE 10	SCHEDULE 20	SCHEDULE 30	SCHEDULE 40	STANDARD	SCHEDULE 60	SCHEDULE 80	X-HEAVY	SCHEDULE 100	SCHEDULE 120	SCHEDULE 140	SCHEDULE 160	XK-HEAVY
1/8	10,28	Wall thickness	0,89	1,24			1,73	1,73		2,41	2,41					
		Inside diameter	8,51				6,83	6,83		5,46	5,46					
1/4	13,71	Wall thickness	1,24	1,65			2,24	2,24		3,02	3,02					
		Inside diameter	11,23	10,41			9,25	9,25		7,67	7,67					
3/8	17,14	Wall thickness	1,24	1,65			2,31	2,31		3,20	3,20					
		Inside diameter	14,66	13,84			12,52	12,52		10,74	10,74					
1/2	21,33	Wall thickness	1,65	2,11			2,77	2,77		3,73	3,73				4,75	7,47
		Inside diameter	18,03	17,12			15,80	15,80		13,87	13,87				11,84	11,23
3/4	26,67	Wall thickness	1,65	2,11			2,87	2,87		3,91	3,91				5,54	7,82
		Inside diameter	23,37	22,45			20,93	20,93		18,85	18,85				15,60	11,02
1	33,40	Wall thickness	1,65	4,83			3,38	3,38		4,55	4,55				6,35	9,09
		Inside diameter	30,10	23,75			26,64	26,64		24,31	24,31				20,70	15,21
1 1/4	42,16	Wall thickness	1,65	2,77			3,56	3,56		4,85	4,85				6,35	9,70
		Inside diameter	38,86	36,63			35,05	35,05		32,46	32,46				29,46	22,76
1 1/2	48,26	Wall thickness	1,65	2,77			3,68	3,68		5,08	5,08				7,14	10,16
		Inside diameter	44,96	42,72			40,89	40,89		38,10	38,10				33,99	27,94
2	60,32	Wall thickness	1,65	2,77			3,91	3,91		5,54	5,54				8,71	11,07
		Inside diameter	57,02	54,79			52,50	52,50		49,25	49,25				42,90	38,18
2 1/2	73,02	Wall thickness	2,11	3,05			5,16	5,16		7,01	7,01				9,53	14,02
		Inside diameter	68,81	66,93			62,71	62,71		59,00	59,00				53,98	44,98
3	88,90	Wall thickness	2,11	3,05			5,49	5,49		7,62	7,62				11,10	15,24
		Inside diameter	84,68	82,80			77,93	77,93		73,66	73,66				66,70	58,42
3 1/2	101,60	Wall thickness	2,11	3,05			5,74	5,74		8,08	8,08					16,15
		Inside diameter	97,38	95,50			90,12	90,12		85,45	85,45					69,29
4	114,30	Wall thickness	2,11	3,05			6,02	6,02	7,14	8,56	8,56		11,10		13,49	17,12
		Inside diameter	110,08	108,20			102,26	102,26	100,03	97,18	97,18		92,10		87,33	80,06
4 1/2	127,00	Wall thickness						6,27			9,02					18,03
		Inside diameter						114,45			108,97					90,93
5	141,30	Wall thickness	2,77	3,40			6,55	6,55		9,53	9,53		12,70		15,88	19,05
		Inside diameter	135,76	134,49			128,19	128,19		122,25	122,25				109,55	103,20
6	168,27	Wall thickness	2,77	3,40			7,11	7,11		10,97	10,97		14,27		18,24	21,95
		Inside diameter	162,74	161,47			154,05	154,05		146,33	146,33				131,80	124,38
7	193,67	Wall thickness						7,65			12,70					22,23
		Inside diameter						178,38			168,28					149,23
8	219,07	Wall thickness	2,77	3,76	6,35	7,04	8,18	8,18	10,31	12,70	12,70	15,06	18,24	20,62	23,01	22,23
		Inside diameter	213,54	211,56	206,38	205,00	202,72	202,72	198,45	193,68	193,68	188,95	182,60	177,83	173,05	174,63
9	244,47	Wall thickness						8,69			12,70					
		Inside diameter						227,10			219,08					
10	273,05	Wall thickness	3,40	4,19	6,35	7,80	9,27	9,27	12,70	15,06	12,70	18,24	21,41	25,40	28,58	
		Inside diameter	266,24	264,67	260,35	257,45	254,51	254,51	247,65	242,93	247,65	236,58	230,23	222,25	215,90	
11	298,45	Wall thickness						9,53			12,70					
		Inside diameter						279,40			273,05					
12	323,85	Wall thickness	3,96	4,57	6,35	8,38	10,31	9,53	14,27	17,45	12,70	21,41	25,40	28,58	33,32	
		Inside diameter	315,93	314,71	311,15	307,09	303,23	304,80	295,30	288,95	298,45	281,03	273,05	266,70	257,20	
14	355,60	Wall thickness	3,96	6,35	7,92	9,53	11,10	9,53	15,06	19,05	12,70	23,80	27,62	31,75	35,71	
		Inside diameter	347,68	342,90	339,75	336,55	333,40	336,55	325,48	317,50	330,20	308,00	-199,64	292,10	284,18	
16	406,40	Wall thickness	4,19	6,35	7,92	9,53	12,70	9,53	16,66	21,41	12,70	26,19	30,94	36,50	40,46	
		Inside diameter	398,02	393,70	390,55	387,35	381,00	387,35	373,08	363,58	381,00	354,03	344,53	333,40	325,48	
18	457,20	Wall thickness	4,19	6,35	7,92	11,10	14,27	9,53	19,05	23,80	12,70	29,36	34,93	39,67	45,24	
		Inside diameter	448,82	444,50	441,35	435,00	428,65	438,15	419,10	409,60	431,80	398,48	387,35	377,85	366,73	
20	508,00	Wall thickness	4,78	6,35	9,53	12,70	15,06	9,53	20,62	26,19	12,70	32,51	38,10	44,45	49,99	
		Inside diameter	498,45	495,30	488,95	482,60	477,88	488,95	466,75	455,63	482,60	442,98	431,80	419,10	408,03	
24	609,60	Wall thickness	5,54	6,35	9,53	14,27	17,45	9,53	24,59	30,94	12,70	38,89	46,02	52,37	59,51	
		Inside diameter	598,53	596,90	590,55	581,05	574,70	590,55	560,43	547,73	584,20	531,83	517,55	504,85	490,58	
26	660,40	Wall thickness		7,92	12,70			9,53			12,70					
		Inside diameter		644,55	635,00			641,35			635,00					
28	711,20	Wall thickness		7,92	12,70	15,88		9,53			12,70					
		Inside diameter		695,35	685,80	679,45		692,15			685,80					
30	762,00	Wall thickness	6,35	7,92	12,70	15,88		9,53			12,70					
		Inside diameter	749,30	746,15	736,60	730,25		742,95			736,60					
32	812,80	Wall thickness		7,92	12,70	15,88	17,48	9,53			12,70					
		Inside diameter		796,95	787,40	781,05	777,85	793,75			787,40					
34	863,60	Wall thickness		8,74	12,70	15,88	17,48	9,53			12,70					
		Inside diameter		846,12	838,20	831,85	828,65	844,55								
36	914,40	Wall thickness		7,92	12,70	15,88	19,05	9,53			12,70					
		Inside diameter		898,55	889,00	882,65	876,30	895,35			889,00					
42	1 066,80	Wall thickness						9,53			12,70					
		Inside diameter						1 047,75			1 041,40					
48	1 219,20	Wall thickness						9,53			12,70					
		Inside diameter						1 200,15			1 193,80					

WEIGHTS

GIVEN	MULTIPLY BY	TO OBTAIN
Grams	0.001	Kilograms
Grams	0.0353	Ounces
Grams	0.0022	Pounds
Kilograms	1 000.0	Grams
Kilograms	35.2740	Ounces
Kilograms	2.2046	Pounds
Ounces	28.3495	Grams
Ounces	0.0283	Kilograms
Ounces	0.0625	Pounds
Pounds	453.5924	Grams
Pounds	0.4536	Kilograms
Pounds	16.0	Ounces

MEASURES

GIVEN	MULTIPLY BY	TO OBTAIN
Centimeters	0.0328	Feet
Centimeters	0.3937	Inches
Centimeters	10.0	Millimeters
Centimeters	0.01	Meters
Feet	30.4801	Centimeters
Feet	12.0	Inches
Feet	304.801	Millimeters
Feet	0.3048	Meters
Inches	2.5400	Centimeters
Inches	0.0833	Feet
Inches	25.400	Millimeters
Inches	0.0254	Meters
Millimeters	0.1	Centimeters
Millimeters	0.00328	Feet
Millimeters	0.03937	Inches
Millimeters	0.001	Meters
Meters	100.0	Centimeters
Meters	3.2808	Feet
Meters	39.370	Inches
Meters	1 000.0	Millimeters

FLOW RATE

GIVEN	MULTIPLY BY	TO OBTAIN
Cubic feet per minute (CFM)	0.0283	Cubic meters per minute
Cubic feet per minute (CFM)	7.4805	Gallons per minute (GPM)
Cubic feet per minute (CFM)	28.3163	Liters per minute
Cubic meters per minute	35.3133	Cubic feet per minute (CFM)
Cubic meters per minute	264.170	Gallons per minute (GPM)
Cubic meters per minute	1 000.0	Liters per minute
Gallons per minute (GPM)	0.1337	Cubic feet per minute (CFM)
Gallons per minute (GPM)	0.0038	Cubic meters per minute
Gallons per minute (GPM)	3.7878	Liters per minute
Liters per minute	0.0353	Cubic feet per minute (CFM)
Liters per minute	0.001	Cubic meters per minute
Liters per minute	0.2641	Gallons per minute (GPM)

PRESSURE

GIVEN	MULTIPLY BY	TO OBTAIN
Bar	1.0197	Kilograms per square centimeter
Bar	14.5038	Pounds per square inch
Kilograms per square centimeter	.9807	Bar
Kilograms per square centimeter	14.22	Pounds per square inch
Pounds per square inch	.0689	Bar
Pounds per square inch	.0703	Kilograms per square centimeter



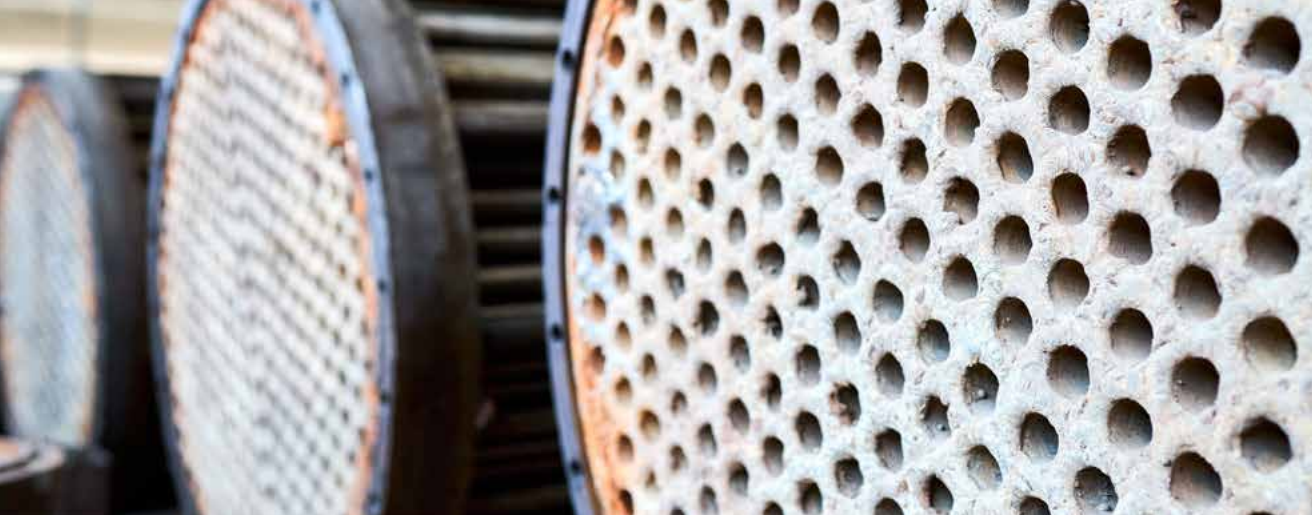

KRAIS Tube&Pipe Tools

Poland, 55-106 Zawonia, Czachowo 15

tel. +48 71 312 05 96, fax +48 71 387 03 32

email: export@krais.com

www.krais.com



 facebook.com/KraisTubeExpanders/

 linkedin.com/company/krais/

