

www.krais.com



Flange Management Professional Tools



 **KRAIS**[®]
Tube & Pipe Tools

Manual FlangeMill | Mini Flange Facer | Narrow Body Flange Facer | Internal Mounted Flange Facers

Manual FlangeMill

Basic, simple and cost-effective solution for ID mount flange facing. It is a quick and easy way to reface a damaged flat, grooves in pipe flanges on site. Manual FlangeMill size and body is designed and built to allow quick and convenient processing of small flanges in awkward or dangerous locations.

With its robust cage-type frame, the MFM ensures exceptional stiffness and precision, unmatched by other hand-operated flange milling machines in the market.

TOOL SWING DIAMETERS

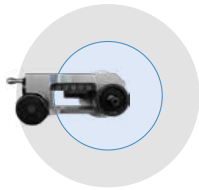

FACING RANGE

BODY SWING DIAMETER



FACING RANGE	LOCKING RANGE	MAX V TOOL TRAVEL	MAX H TOOL TRAVEL	BODY SWING DIAMETER		
30 – 350 mm	25,4 - 254,0 MM	10 MM	55 MM	457,2 MM		
1,750 – 14,000"	1 - 10"	0,395"	2,165"	18"		
DRIVE	BODY WIDTH		BODY LENGHT		BODY WEIGHT	
Manual	6,5"	165 mm	12,8"	325 mm	19,4 Lbs	8,8 kg

MFM TOOL BITS AND HOLDER



Manual Flange Mill uses one just type of holders: MFMH-7-L and MFMH-7-R with carbide insert C17 (screw MHS-2,7)

	A	B
C17	7	7
mm		

MFM ADVANTAGES



PRECISE DEPTH ADJUSTMENT
The tool depth can be adjusted (10 mm stroke) thru spindle to define cut depth and the correct finish.



EASE OF USE
The tool arm is rotated by hand using a worm-gear mechanism to provide a perfect spiral finish.



SMOOTH OPERATION
Quick adjustment handle to move the cutter to groove position



MACHINING IN EVERY POSITION
Manual FlangeMill can be freely rotated to work in every position. Remachining damaged flat, grooves and raised faced flanges on site is possible in every position.

TOOLING CHART

HOLDER	INSERT	SCREW	TORX
MFMH-7-L	C17	MHS-2,7	TX-8
MFMH-7-R	C17	MHS-2,7	TX-8

EXAMPLE TOOL APPLICATION



MFM-OMM Module

Outside mounting module for MFM

Expand the capabilities of your KRAIS Manual FlangeMill with the MFM-OMM conversion module. This compact and purpose-built solution enables secure outside mounting, allowing you to face flanges even in situations where internal mounting is not possible—such as with very small diameter flanges or restricted access areas.

With the MFM-OMM, there's no need to invest in additional mini facers or dedicated outside-mount tools. The module lets you easily switch between internal and external mounting configurations without compromising on performance or precision.

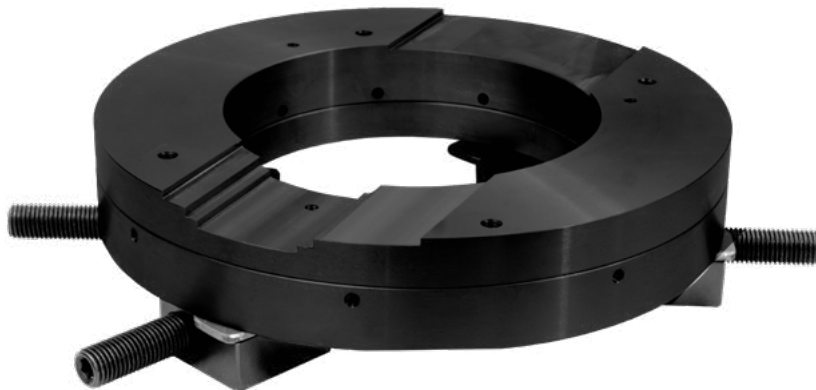

FEATURES

- ▶ **Rigidity** - significantly greater compared to mini flange facers, which are used on small-diameter miniature shafts that tend to bend under the pressure during the rotational force of a long arm.
- ▶ **Cost-effective** - eliminates the need for additional, expensive tools
- ▶ **Versatile** - quick and easy switching between mounting setups
- ▶ **Compact design** - ideal for small flanges and hard-to-reach locations

WORKING PARAMETERS FOR MANUAL FLANGEMILL WITH THE MODULE						
FACING RANGE	OD LOCKING RANGE		FEED STROKE	ADJUSTABLE JAWS		
0 to 127 mm	95,3 to 155,4 mm		31,70 MM	4		
0" to 5"	3,752" to 6,118"		1,248"			
DRIVE	BODY WIDTH		BODY LENGHT		BODY WEIGHT	
Manual	6,5"	165 mm	12,8"	325 mm	19,4 Lbs	8,8 kg

The MFM-OMM is designed exclusively for the Manual FlangeMill 14.

TOOL SWING DIAMETERS

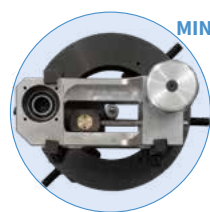

Tool without crank, with bit in position 0 mm



Tool with crank, bit in position 127 mm

OUTSIDE-MOUNTED - READY TO FACE



The MFM-OMM module securely installed on a pipe flange with the Manual FlangeMill. Designed for field use, this setup allows precise facing of small flanges directly from the outside—ideal for tight or inaccessible locations.

QUICK CONVERSION

Switching your Manual FlangeMill to outside mounting is fast and simple – just tighten four clamps and you're ready to face flanges from the outside. No need for disassembly or additional tools.



Manual FlangeMill Long

Long version of simple and cost-effective solution for ID mount flange facing. It is a quick and easy way to reface a damaged flat, grooves in pipe flanges on site. The L(ong) version FlangeMill size and body is designed and built to allow quick and convenient processing of mid sized flanges in awkward or dangerous locations.



TOOL SWING DIAMETERS

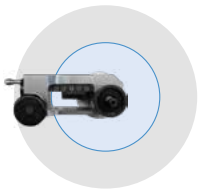

FACING RANGE

BODY SWING DIAMETER

FACING RANGE	LOCKING RANGE	MAX V TOOL TRAVEL	MAX H TOOL TRAVEL	BODY SWING DIAMETER		
51 – 650 mm	51 - 550 MM	10 MM	55 MM	757 MM		
2,01 – 25,60"	2,01 - 21,65"	0,395"	2,165"	30"		
DRIVE	BODY WIDTH		BODY HEIGHT		BODY WEIGHT	
Manual	6,5"	165 mm	18,7"	475 mm	19,4 Lbs	8,8 kg

MFM TOOL BITS AND HOLDER



Manual Flange Mill uses one just type of holders: MFMH-7-L and MFMH-7-R with carbide insert CI7 (screw MHS-2,7)

	A	B
CI7 mm	7	7

MFM ADVANTAGES



PRECISE DEPTH ADJUSTMENT
The tool depth can be adjusted (10 mm stroke) thru spindle to define cut depth and the correct finish.



EASE OF USE
The tool arm is rotated by hand using a worm-gear mechanism to provide a perfect spiral finish.



SMOOTH OPERATION
Quick adjustment handle to move the cutter to groove position



MACHINING IN EVERY POSITION
Manual FlangeMill can be freely rotated to work in every position. Remachining damaged flat, grooves and raised faced flanges on site is possible in every position.

TOOLING CHART

HOLDER	INSERT	SCREW	TORX
MFMH-7-L	CI7	MHS-2,7	TX-8
MFMH-7-R	CI7	MHS-2,7	TX-8

MFF-125, Mini Flange Facer

Highly efficient and lightweight flange facing machine – among the most compact options available today.

- ▶ Minimal clearance required
- ▶ Suitable for flat and raised face flanges
- ▶ Reinforced stainless steel body for enhanced machine stability
- ▶ Robust aluminum facing head, bolstered by multiple bearings
- ▶ Durable mandrel shaft with a secure jaw set for firm mounting
- ▶ Precision-engineered, hardened, and ground tool slides
- ▶ Available with a 1.3 Hp pneumatic drive or 750 W electric motor, equipped with a multi-stage planetary gearbox

PREMIUM COMPONENTS

- ▶ The pneumatic motor is fully equipped with a filter, lubricator, and flow control system.
- ▶ Streamlined, low-profile drive system designed to deliver exceptional power-to-weight efficiency.
- ▶ Built with a sturdy main body, heavy-duty bearings, sealed lubrication, and a solid mounting system for reliable performance.



FACING RANGE		LOCKING RANGE		VERTICAL FEED STROKE		MACHINING FEED RATE		POWER	
20 – 125 mm		20 – 88 mm		13 mm		0,125 to 0,5 mm		1,3 Hp	
0.787 – 4.921"		0.787 – 3.465"		0,5"		0,005 to 0,019"			
AIR USE		WEIGHT		HEIGHT		LENGTH		SWING DIAMETER	
55 cfm	1,3 m³/min	23,81 Lbs	10,80 kg	14,5"	372,0 mm	11,8"	300 mm	8,86"	225 mm

AUTOMATIC FEED



FEED TRIPPERS

The machine is equipped with four trippers, allowing to make four feed rates to produce cores and fine surfaces. Using two or more trippers simulates the gramophone groove.

- 1 strike 0,125 mm per rev / 203 rev per 1"
- 2 strikes 0,250 mm oer rev / 101 rev per 1"
- 3 strikes 0,375 mm per rev / 67 rev per 1"
- 4 strikes 0,500 mm per rev / 51 rev per 1"

The tool is equipped with automatic feed system. The feed rate is set in a simple and quick manner.

MFF-125, Mini Flange Facer

EASY SETUP



The device has clear markings that help to precisely set the required machining and grooving depth.

RIGID LOCKING SYSTEM



Precise flange machining is also achieved thanks to the three jaws with six locking points, which hold it very securely inside the tube.



Handy depth feed locking system to prevent accidental movement of the handle during flange processing.

TOOL HOLDERS RANGES

MFF-125 is a low clearance flange facing machine. To achieve this multiple tool holders are required to cover full range.

HOLDER	INSERT	SCREW	TORX
MFF-V11-L	CI-3-1	MHS-4	TX-15
MFF-V11-P			

MFF-125-E

Electric version of regular tool. A standard machine covers the same flange sizes and comes with the same cutting head.

The electric motor, made by Makita with 3 stage planetary gear box made by KRAIS has variable speed control and produce enormous torque. Is interchangeable with pneumatic drive and can be purchased separately at any time. Also available with battery driven motor!

Free Speed..... 115 RPM
Power..... 750 W
Torque..... 360 Nm (266 Ft.Lbs)



BATTERY OPTION

The machine is also available with a portable electric drive 18 Volt 5.2 Ah 93.6 Wh Li-Ion battery. The machine can operate up to 15-20 minutes on one battery.

Machining itself of one flange takes about 3-4 minutes of motor operation, so the operating time on one battery may suffice on 3-4 flanges. It is possible to have many charged batteries. Comfortable and easy to use in any place where compressed air and electricity is not available or even impossible to use as for example oil refinery.



NBFF – Narrow Body Flange Face

*Patent pending

NBFF – the flange facing machine with a slim line gantry profile for mounting in tight spaces. An operator can mount NBFF tool on-site within demanding conditions such as flanges close to walls or pipe racks.

The unique design of NBFF allows the operator to mount the machine and perform a repair in locations that popular, standard equipment could not fit. The machine conforms to all the necessary standards and is extremely easy to use. Light and robust to quickly mount and repair damaged faces on flanges. NBFF can maximize production and uptime in all flange management jobs.



SUPER NARROW BODY

Thanks to unique, a true narrow design NBFF tool is fully usable within demanding conditions such as flanges close to walls or pipe racks.

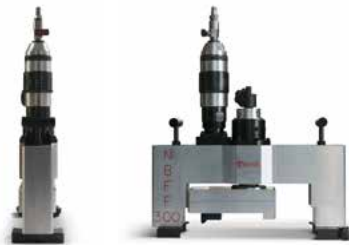

	FACING RANGE [MM]		FACING RANGE [INCH]		CLAMPING RANGE [MM]		CLAMPING RANGE [INCH]		MAX. SWING DIAMETER		TOOL POST TRAVEL		FREE SPEED	POWER	
	MIN	MAX	MIN	MAX	MIN	MAX	MIN	MAX	[MM]	[INCH]	[MM]	[INCH]	[RPM]	[KW]	[HP]
NBFF-115	0	125	0"	4,921	89	170	3,504	6,693	125	4,921	62,5	2,461	100	0,97	1,3
NBFF-160	0	185	0"	7,283	89	280	3,504	11,024	185	7,283	92,5	3,642	115	1,6	2,2
NBFF-300	0	310	0"	12,205	108	356	4,252	14,016	310	12,205	155	6,102	85	1,6	2,2
NBFF-600															

	AIR USE		DIMENSIONS		WEIGHT	
	[CFM]	[M ³ /MIN]	[MM]	[INCH]	[KG]	[LBS]
NBFF-115	55	1,3	65 (100) x 460 x 260	2,55" (3,93") x 18,11" x 10,23"	25	55,11
NBFF-160	75	2,2	70 (100) x 510 x 340	2,75" (3,93") x 20,07" x 13,38"	27	59,5
NBFF-300	75	2,2	70 (100) x 510 x 470	2,75" (3,93") x 20,07" x 18,50"	32	70,5
NBFF-600						

FEED RATES

Feed rates pitch mm			
0,5	0,75	1*	1,25
Grooves per inch			
104	69	52	41

* standard feed screw supplied with machine

CHOICE OF THREE

All versions of NBFF deliver the same advantage over standard flange facers: despite working size all are narrow and fit perfectly in tight spaces.



TOOLING CHART

HOLDER	INSERT	SCREW	TORX
NBFF-C17	C17	MHS-2,7	TX-8

NBFF – Narrow Body Flange Facer

STANDARD LOCKING SYSTEM



The standard locking system consists of two jaws. One of them is a stabilizing jaw with two adjustable screws to fit the outer diameter of the flange. The second jaw has three clamping screws. Both jaws are equipped with pair top pads for levelling on the sealing surface of the flange. Pads at the bottom, are for tension the machine to the flange surface. Pads help to fix the machine in any position and protect it from falling out of the flange in case of a collision.

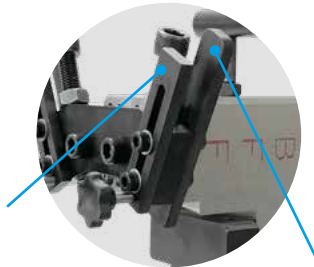

Pads at the bottom, are for tension the machine to the flange surface and protect it from falling out of the flange in case of a collision.

Top pads are for levelling on the sealing surface of the flange.

REAL LIFE EXAMPLE



Example of really tight flange – NBFF is the only tool suitable here.

NBFF-E

NBFF-E is electric version of NBFF. A standard machine covers the same flange sizes and comes with the same cutting head. The electric motor, made by Makita with 3 stage planetary gear box made by KRAIS has variable speed control and produce enormous torque. Is interchangeable with pneumatic drive and can be purchased separately at any time.

Free Speed.... 115 RPM
Power..... 750 W
Torque..... 360 Nm (266 Ft.Lbs)

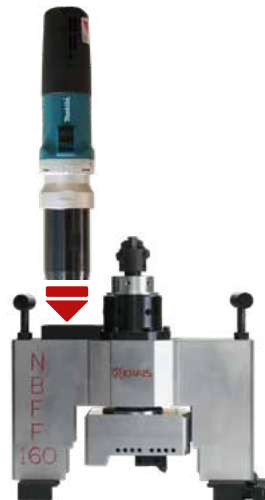

FLANGE2FLANGE LOCKING OPTION

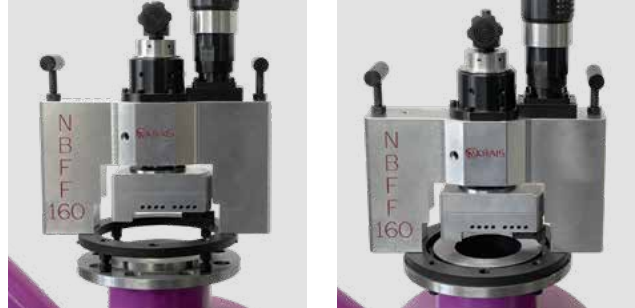

Additional, special flange type locking system is made to suit the application more. NBFF machine is still mounted on the flange outside diameter, but the locking system is equipped with additional studs to be mounted in the flange holes to provide easy operation and perfect centring.

NBFF IN ACTION



BATTERY OPTION

The machine is also available with a portable electric drive 18 Volt 5.2 Ah 93.6 Wh Li-Ion battery. The machine can operate up to 15-20 minutes on one battery. Machining itself of one flange takes about 3-4 minutes of motor operation, so the operating time on one battery may suffice on 3-4 flanges. It is possible to have many charged batteries. Comfortable and easy to use in any place where compressed air and electricity is not available or even impossible to use as for example oil refinery.



OMFM-305

The OMFM-305 is a high-performance, externally mounted machine tool designed for demanding flange machining applications. With its lightweight yet super-rigid construction, the OMFM-305 combines portability with the heavy-duty strength required for precision machining of various flange faces, seal grooves, weld preparations, and counterbores. Its robust design, featuring heavy-duty steel and aluminum components, ensures exceptional durability and reliability in the toughest environments.

KEY FEATURES:

- ▶ Externally mounted, lightweight yet heavy-duty machine.
- ▶ Heavy-duty steel/aluminum construction for durability and precision.
- ▶ High rigidity due to cast steel body and steel body plate.
- ▶ Continuous groove facing feed with 2-speed gearbox for precision finishes.
- ▶ Swivel tool post for grooves, RTJ flanges, and bevels.
- ▶ Complete toolkit with CE certification.



STANDARD WORKING RANGE		FACING FEEDS		FREE SPEED	POWER		
FACING RANGE	LOCKING RANGE	COARSE FEED	FINE FEED				
0 - 305 mm	50,8 - 305,4 mm	0,5 mm (0,020") / Revolution	0,125 mm (0,005") / Revolution	30 Rpm	2,2 Hp		
0" to 12"	2" - 12"	50 Grooves per inch	203 Grooves per inch		1,6 kW		
AIR USE		MACHINE WEIGHT		DRIVE WEIGHT			
75 cfm	2,2 m ³ /min	43 kg	95 Lbs	5 kg	11,0 Lbs		
				SHIPPING BOX		SHIPPING WEIGHT	
				75 x 55 x 35 cm	30" x 22" x 14"	86 kg	189 Lbs

COMPLETE TOOLING PACKAGE

The OMFM-305 comes with a comprehensive toolkit, including all necessary tools, inserts, an air filter lubricator, a hose connection, mounting feet, and extensions. The machine is supplied with a storage and shipping box for easy transport and protection. Additionally, the package includes a CE certificate, packing list, and user manual, ensuring compliance with industry standards and providing operators with all the information needed for safe and effective use.

TOOLING CHART

HOLDER	INSERT	SCREW	TORX
IMFM24-V11-L	CIV-11-3-1	MHS-4	TX-15
IMFM24-V11-N	CIV-11-3-1	MHS-4	TX-15
IMFM24-V11-P	CIV-11-3-1	MHS-4	TX-15

OMFM-305

SWIVEL TOOL

Swivel tool post for grooves, RTJ flanges, and bevels

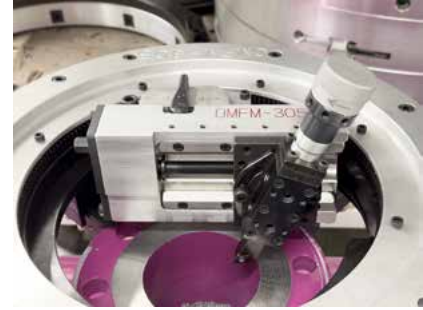
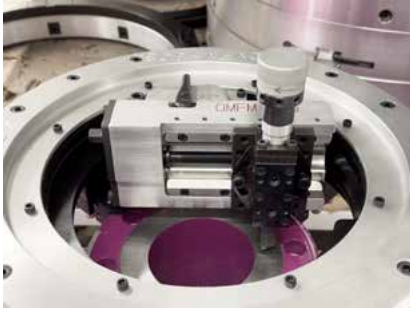

ELECTRIC DRIVE

As an option, we can deliver the electric motor, made by Makita. With 3 stage planetary gear box made by KRAIS, the drive has variable speed control and produce enormous torque. Is interchangeable with pneumatic drive and can be purchased separately at any time. Also available with battery driven motor!

Free Speed..... 115 RPM
Power..... 750 W
Torque..... 360 Nm (266 Ft.Lbs)



CONVENIENT JAWS



Special jaw set for easy and quick levelling and centring machine. A special mechanism allows convenient adjustment of the mounting plane relative to the pipe.

TIGHT SPACES

The OMFM-305 is also highly effective in hard-to-reach areas. It allows for the drive motor to be mounted on either side of the machine, making it ideal for machining flanges in confined spaces. Additionally, the optional angle module enables horizontal motor installation for even greater flexibility.



EFFICIENT ON-SITE OPERATION

The OMFM-305 is the ideal solution for professionals requiring a rugged and reliable machine for high-precision flange machining tasks. Its lightweight design, combined with heavy-duty construction and easy setup, makes it a versatile tool for a wide range of industrial applications.



IMFM-24/30

Internally mounted, lightweight, super rigid yet super heavy-duty machine tool. Ideal for machining all types of flange faces, seal grooves, weld preparations and counterbores.

- ▶ Heavy-duty steel/aluminium all design.
- ▶ Heavy-duty cast steel body and steel body plate.
- ▶ Solid construction and high rigidity of the machine concerning the dimension and weight.
- ▶ Continuous groove facing feed, 2-speed gearbox.
- ▶ Swivel tool post for grooves, RTJ flanges, and bevels.
- ▶ Quick-set independent bases for improved on-site operation.
- ▶ Fast mounted arm with spindle for the very convenient measure of levelling and centring.
- ▶ Super quick machine fixing to the locking base.
- ▶ Special jaw set for easy and quick levelling and centring machine; jaws are interchangeable with all IMFM series Flange Facers.
- ▶ CE certificate.



STANDARD WORKING RANGE		FACING FEEDS			FREE SPEED	POWER					
FACING RANGE	LOCKING RANGE	1,75 MM SCREW	1,25 MM SCREW	1,00 MM SCREW							
145 – 762 mm	140 - 670 mm	0,2 / 0,8 mm	0,14 / 0,57 mm	0,15 / 0,45 mm	20 - 42 Rpm	2,2 Hp					
5" - 30"	5-1/2" - 26"	0,008 / 0,031"	0,006 / 0,022"	0,004 / 0,018"		1,6 kW					
AIR USE		MACHINE WEIGHT		DRIVE WEIGHT		MAX BIG BASE WEIGHT	MAX SMALL BASE WEIGHT	COUNTER WEIGHT			
75 cfm	2,2 m ³ /min	26 kg	57,4 Lbs	5 kg	11,0 Lbs	18 kg	39,7 Lbs	4 kg	8,82 Lbs	6 kg	13,23 Lbs

	SHIPPING BOX		SHIPPING WEIGHT	
	75 x 55 x 35 cm	30" x 22" x 14"	80 kg	177 Lbs

TOOLING CHART

HOLDER	INSERT	SCREW	TORX
IMFM24-V11	CIV-11-3-1	MHS-4	TX-15

COMPLETE PACKAGE

As standard IMFM is supplied with the complete toolkit, including cutting tool and inserts and hose connection, required jaws to cover the full range, user manual and storage shipping box.

For IMFM, besides standard pneumatic 2,2 Hp drive, we offer a wide choice of pneumatic and electric drives.

UNIQUE RIGIDITY

High rigidity of the machine in relation to the dimension and weight by applying Heavy-duty cast steel body and steel body plate.



WIDE RANGE

Machine is equipped with 2 locking bases
Big 250-700 mm
Small 140 – 290 mm



IMFM-24/30

SWIVEL TOOL

Swivel tool post for grooves, RTJ flanges, and bevels



CONVENIENT JAWS

Special jaw set for easy and quick levelling and centring machine. A special mechanism allows convenient adjustment of the mounting plane relative to the pipe. Jaws are interchangeable with all IMFM series Flange Facers.



PRECISE MOUNTING



Fast mounted arm with spindle for the very convenient measure of levelling and cantering

FAST FIXING

Super fast machine fixing with locking base by means of a taper in the locking base and taper seat in the spindle fastened with a central locking screw

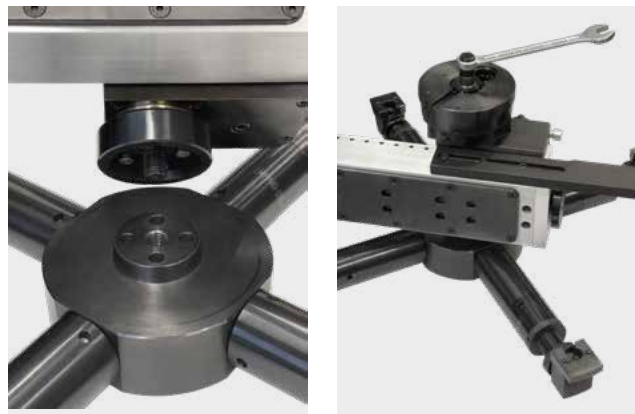

RIGHT ANGLE HEAD



This optional addon allows for fastening drive in alternate positions. The useful option in tight spaces.

ELECTRIC DRIVE

As an option, we can deliver the electric motor, made by Makita. With 3 stage planetary gear box made by KRAIS, the drive has variable speed control and produce enormous torque. Is interchangeable with pneumatic drive and can be purchased separately at any time. Also available with battery driven motor!

Free Speed..... 115 RPM
Power..... 750 W
Torque..... 360 Nm (266 Ft.Lbs)



IMFM-24 Internal Mounted Flange Mill

Internally mounted, lightweight and durable machine tool. Ideal for machining all types of flange faces, seal grooves, weld preparations and counterbores.

Features:

- ▶ Heavy-duty steel/aluminium design
- ▶ High rigidity of the machine in relation to the dimension and weight
- ▶ Solid but lightweight construction
- ▶ Continuous groove facing feeds
- ▶ Swivel tool post for grooves, RTJ flanges and bevels
- ▶ Easy levelling and centering system with built-in fast centre feature
- ▶ Quick clamping with solid, 50 mm self-centering steel shaft
- ▶ CE certificate

As standard IMFM is supplied with the complete toolkit, including cutting tool and inserts and hose connection, required jaws to cover the full range, paper manual and storage/shipping box. Beside standard pneumatic 2,2 Hp drive, for IMFM we offer a wide choice of pneumatic and electric drives.



STANDARD WORKING RANGE		FACING FEEDS			FREE SPEED	POWER	
FACING RANGE	LOCKING RANGE	1,75 MM SCREW	1,25 MM SCREW	1,00 MM SCREW			
100 – 610 mm	100 - 508 mm	0,2 / 0,8 mm	0,14 / 0,57 mm	0,15 / 0,45 mm	20 - 42 Rpm	2,2 Hp	
3,93 - 24,00"	3,93 - 20,00"	0,008 / 0,031"	0,006 / 0,022"	0,004 / 0,018"		1,6 kW	
AIR USE		BODY WIDTH		BODY HEIGHT		BODY WEIGHT	
75 cfm	2,2 m³/min	Depends on motor configuration, see drawing below		99 Lbs	45 kg		

LEVELLING & CENTERING



Special jaw set for easy and quick levelling and centering machines on the flange

TOOLING CHART

HOLDER	INSERT	SCREW	TORX
IMFM24-V11	CIV-11-3-1	MHS-4	TX-15

DIMENSIONS

INLINE VERSION

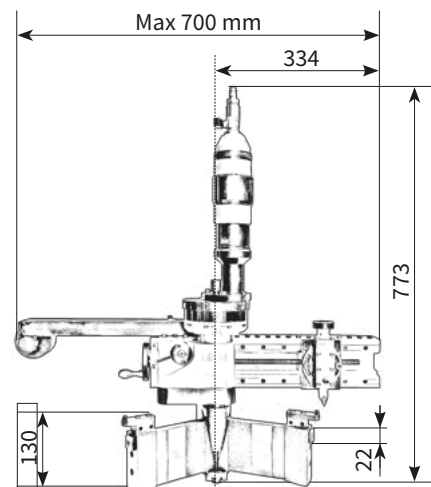

RIGHTANGLE VERSION

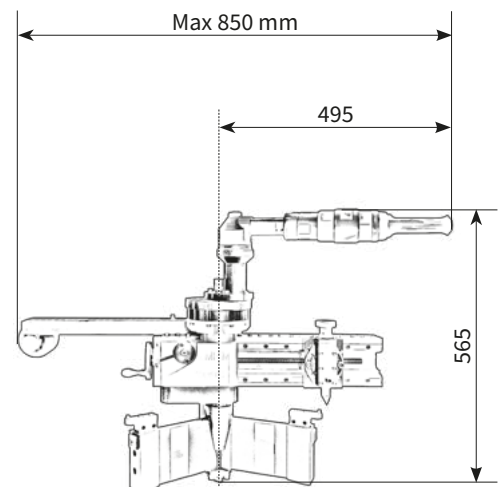

IMFM-40 Internal Mounted FlangeMill

Internally mounted, lightweight and durable machine tool. Ideal for machining all types of flange faces, seal grooves, weld preparations and counterbores.

- ▶ Heavy-duty steel/aluminium design with solid but lightweight construction
- ▶ High rigidity of the machine in relation to the dimension and weight
- ▶ Continuous groove facing feeds
- ▶ Swivel tool post for grooves, RTJ flanges and bevels
- ▶ Easy levelling and centering system with built-in self-centre feature
- ▶ Quick clamping with solid, 50 mm self-centering steel shaft
- ▶ CE certificate

As standard IMFM is supplied with the complete toolkit, including cutting tool and inserts and hose connection, required jaws to cover the full range, paper manual and storage/shipping box. Beside standard pneumatic 2,2 Hp drive, for IMFM we offer a wide choice of pneumatic and electric drives.



STANDARD WORKING RANGE		MAX SWING DIAMETER	TOOL POST TRAVEL	FEED RATES	FREE SPEED	POWER					
FACING RANGE	CLAMPING RANGE										
322 – 1016 mm	322 - 915 mm	1220 mm	102 mm	See table	0 - 24 Rpm	2,2 Hp					
12,67 - 40,00"	12,67 - 36,00"	48"	4"			1,6 kW					
AIR USE		SHIPPING WIDTH		SHIPPING HEIGHT		SHIPPING LENGTH		BODY WEIGHT		SHIPPING WEIGHT	
75 cfm	2,2 m ³ /min	600 mm	24"	725 mm	28,5"	845 mm	34"	145 kg	319 Lbs	210 kg	462 Lbs

FACING FEED RATES (3 OFF IN/OUT)

Direction	Gear	mm/rev	inch/rev	grooves per cm	grooves per inch
Out	1	0,139	0,005	72	183
	2	0,217	0,009	46	117
	3	0,528	0,021	19	48
In	1	0,165	0,006	61	154
	2	0,258	0,010	39	98
	3	0,628	0,025	16	40

BORING FEED RATES (3 OFF UP/DOWN)

mm/rev	inches/rev
0.05 – 0.10 – 0.20	0.002 – 0.004 – 0.008

TOOLING CHART

HOLDER	INSERT	SCREW	TORX
IMFM40F-V11	CIV-11-3-1	MHS-4	TX-15
IMFM40P-V11	CIV-11-3-1	MHS-4	TX-15
IMFM40L-V11	CIV-11-3-1	MHS-4	TX-15

MACHINE IN ACTION

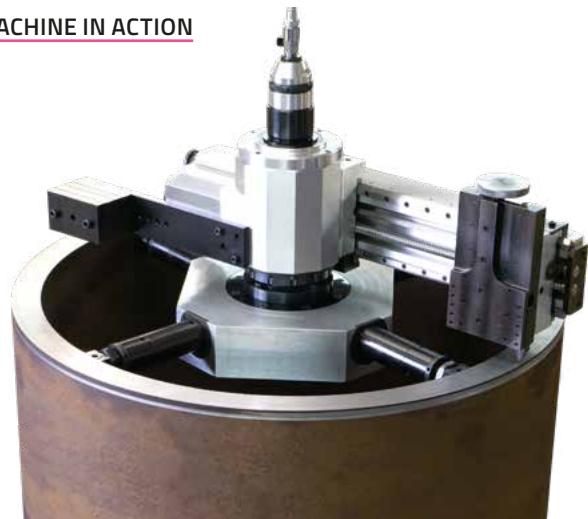

IMFM-40 and IMFM-60 features

LEVELLING AND CENTERING

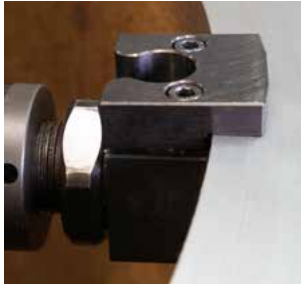

Both machines are equipped with special jaw set for easy, quick levelling and centering. A special mechanism allows convenient adjustment of the mounting plane relative to the pipe. Built-in self-centering locking system significantly facilitates the coarse setting of the machine.

ELECTRIC DRIVE



As an alternative, we offer an electric drive for IMFM40&60. The motor provides similar parameters to the pneumatic one.

SWIVEL TOOL AS A STANDARD

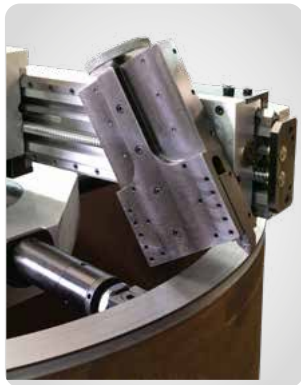

Standard configuration of IMFM is equipped with swivel tool post for grooves, RTJ flanges and bevels

TWO LOCKING PLATES

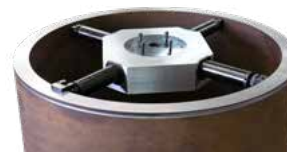

The offer includes two sizes of locking system. Thanks to the matching dimensions of the rigid body, stable mounting and smooth machining of face surfaces and flanges in all pipe sizes is possible.

IMFM-60 Internal Mounted FlangeMill

Internally mounted, lightweight and durable machine tool. Ideal for machining all types of flange faces, seal grooves, weld preparations and counterbores.

- ▶ Heavy-duty steel/aluminium design with solid but lightweight construction
- ▶ High rigidity of the machine in relation to the dimension and weight
- ▶ Continuous groove facing feeds
- ▶ Swivel tool post for grooves, RTJ flanges and bevels
- ▶ Easy levelling and centering system with built-in self-centre feature
- ▶ Quick clamping with solid, 50 mm self-centering steel shaft
- ▶ CE certificate

As standard IMFM is supplied with the complete toolkit, including cutting tool and inserts and hose connection, required jaws to cover the full range, paper manual and storage/shipping box. Beside pneumatic 4,0 Hp drive, for IMFM we offer a wide choice of pneumatic and electric drives.

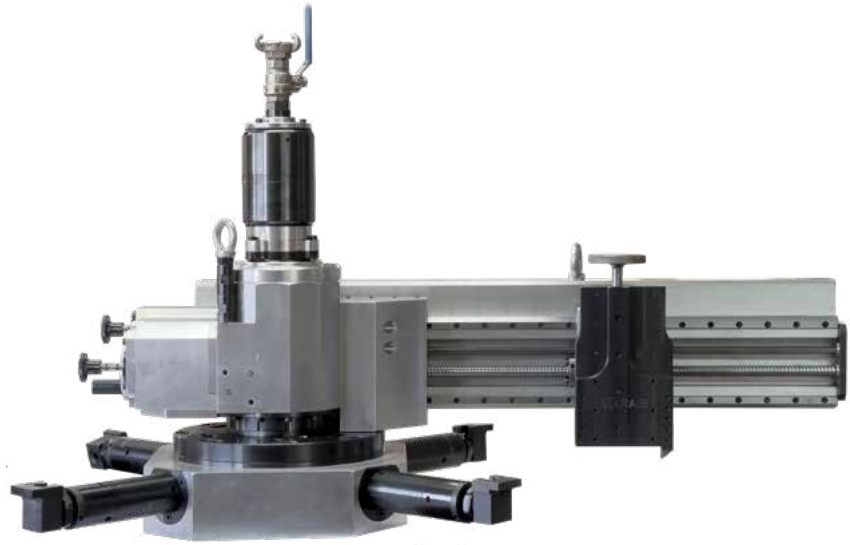

STANDARD WORKING RANGE		MAX SWING DIAMETER	TOOL POST TRAVEL	FEED RATES	FREE SPEED	POWER					
FACING RANGE	CLAMPING RANGE										
507 – 1525 mm	507 - 1400 mm	1745 mm	102 mm	See table	0 - 22 Rpm	4,0 Hp					
20" - 60"	20" - 55"	68"	4"			3,0 kW					
AIR USE		SHIPPING WIDTH		SHIPPING HEIGHT		SHIPPING LENGTH		BODY WEIGHT		SHIPPING WEIGHT	
98 cfm	2,69 m ³ /min	820 mm	32"	830 mm	33"	1230 mm	48"	412 kg	906 Lbs	499 kg	1010 Lbs

FACING FEED RATES (3 OFF IN/OUT)

Direction	Gear	mm/rev	inch/rev	grooves per cm	grooves per inch
Out	1	0,130	0,005	76	195
	2	0,203	0,008	49	125
	3	0,494	0,019	20	51
In	1	0,155	0,006	65	164
	2	0,241	0,009	41	105
	3	0,588	0,023	17	43

BORING FEED RATES (3 OFF UP/DOWN)

mm/rev	inches/rev
0.05 – 0.10 – 0.20	0.002 – 0.004 – 0.008

TOOLING CHART

HOLDER	INSERT	SCREW	TORX
IMFM60F-V11	CIV-11-3-1	MHS-4	TX-15
IMFM60P-V11	CIV-11-3-1	MHS-4	TX-15
IMFM60L-V11	CIV-11-3-1	MHS-4	TX-15

MACHINE FACING 60" FLANGE RING

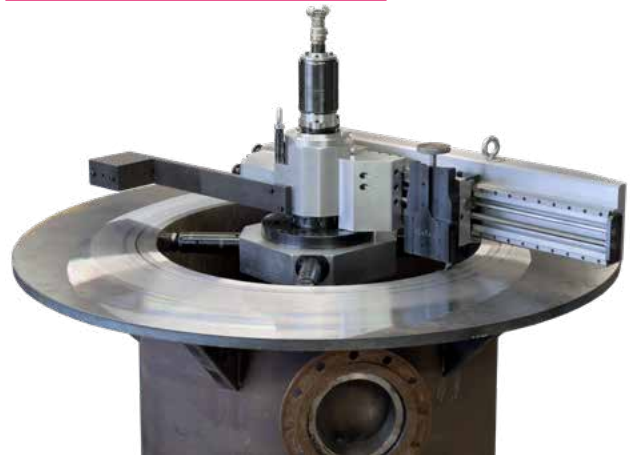

SFFM Flange Facer

SFFM series Flange Facing Machines are mounted on the outer diameter of the flange. The precise, synchronized radial and axial feed mechanism allows for a high quality machining, resulting in one continuous groove producing a true gramophone finish.

SFFM Flange Facing Machines are suitable for various flange types:

- ▶ Flat Face
- ▶ Raised Face
- ▶ Ring Type Joints (RTJ)
- ▶ Tongue & Groove
- ▶ Lens Ring
- ▶ Grayloc® (hub profile)
- ▶ Compact Flanges

SFFM Flange Facers are suitable for the oil and gas industry, power plants, chemical plants, oil rigs and many others. They are prepared to implement applications complying with ASME standards.



MODEL	WORKING RANGE			DIMENSIONS					WEIGHT	JAWS
	UNIT	MIN OD	MAX OD	UNIT	FRAME OD	FRAME ID	FRAME WIDTH	HEIGHT		
SFFM-0410	NPS	2,00	10,00	[inch]	16,22	11,24	2,50	17,3"	57	4
	Metric	50,00	250,00	[mm]	412,00	285,40	63,50	440		
SFFM-1016	NPS	2,00	15,00	[inch]	21,46	16,48	2,50	17,3"	68	6
	Metric	50,00	370,00	[mm]	545,00	418,70	63,50	440		
SFFM-1624	NPS	4,00	23,00	[inch]	29,49	24,41	2,50	17,3"	103	10
	Metric	100,00	580,00	[mm]	749,00	619,90	63,50	440		
SFFM-2836	NPS	8,00	35,00	[inch]	42,15	37,00	2,76	17,3"	180	10
	Metric	200,00	890,00	[mm]	1070,60	939,80	65,40	440		
SFFM-4048	NPS	10,00	47,00	[inch]	54,40	49,53	2,76	17,3"	260	12
	Metric	250,00	1200,00	[mm]	1381,80	1251,00	65,40	440		

FEATURES OF MACHINE

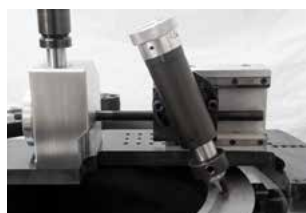

CUTTING GROOVES

The machine offers a simple way of execution of the RTJ grooves by using the single point swivel head or formed tools



GRAMOPHONE GROOVE

The design of the feed attachment assures the automatic and variable feed rate on radial axe producing proper gramophone groove.



STRONG DRIVES

Machine can be driven with a wide range of motors, pneumatic, hydraulic and electrical, including servo drives - all made by KRAIS.



AVAILABLE AS MODULE

For owners of our regular SFSF machines we offer special module, allowing to convert the standard SFSF into regular flange facing module

TOOLING CHART

HOLDER	INSERT	SCREW	TORX
SFFM-V11	CIV-11-3-1	MHS-4	TX-15

SFFM Module

SFFM Module can be mounted on all our SFSF clamshells and convert the regular Clamshell into OD mount flange facing machine. SFSF clamshell combined with the module widens the scope of its application and still providing the same functionality as the machine SFFM.

Purchasing the SFFM Module allows to save a lot of money by avoiding the purchase of two separate machine tools.

Time needed for the machine changeover is only 20 minutes.



SFSF MODEL	WORKING RANGE WITH MODULE			DIMMENSIONS					WEIGHT*	JAWS
	UNIT	MIN OD	MAX OD	UNIT.	FRAME OD	FRAME ID	FRAME WIDTH	BOTH HEIGHT		
SFSF-0410	NPS	0,80	8,80	[inch]	16,22	11,24	2,50	16,25	57,00	4
	Metric	20,00	224,00	[mm]	412,00	285,40	63,50	412,5		
SFSF-0612	NPS	1,60	10,50	[inch]	18,15	13,24	2,50	16,25	59,00	4
	Metric	40,00	270,00	[mm]	461,00	336,20	63,50	412,5		
SFSF-0814	NPS	1,60	12,00	[inch]	19,49	14,48	2,50	16,25	61,00	6
	Metric	40,00	305,00	[mm]	495,00	367,90	63,50	412,5		
SFSF-1016	NPS	1,60	14,00	[inch]	21,46	16,48	2,50	16,29	68,00	6
	Metric	40,00	356,00	[mm]	545,00	418,70	63,50	413,5		
SFSF-1218	NPS	2,00	16,80	[inch]	23,50	18,48	2,50	16,29	83,00	6
	Metric	50,00	427,00	[mm]	597,00	469,50	63,50	413,5		
SFSF-1420	NPS	2,00	20,00	[inch]	25,47	20,85	2,50	16,29	90,00	6
	Metric	50,00	508,00	[mm]	647,00	520,30	63,50	413,5		
SFSF-1624	NPS	2,00	22,70	[inch]	29,49	24,41	2,50	16,29	103,00	10
	Metric	50,00	578,00	[mm]	749,00	619,90	63,50	413,5		
SFSF-2028	NPS	4,00	26,80	[inch]	33,90	28,75	2,76	17,48	145,00	10
	Metric	100,00	681,00	[mm]	861,10	730,30	65,40	443,7		
SFSF-2432	NPS	8,00	30,70	[inch]	38,15	33,00	2,76	17,48	158,00	10
	Metric	200,00	782,00	[mm]	969,00	838,20	65,40	443,7		
SFSF-2836	NPS	8,00	34,80	[inch]	42,15	37,00	2,76	17,48	180,00	10
	Metric	200,00	884,00	[mm]	1070,60	939,80	65,40	443,7		
SFSF-3442	NPS	10,00	40,70	[inch]	48,15	43,00	2,76	17,48	202,00	10
	Metric	250,00	1036,00	[mm]	1223,00	1092,20	65,40	443,7		
SFSF-4048	NPS	10,00	46,80	[inch]	54,40	49,53	2,76	17,48	260,00	12
	Metric	250,00	1189,00	[mm]	1381,80	1251,00	65,40	443,7		

*depends on machine configuration

SURFACE FINISH



The Modul is equipped as standard with feed gearbox in order to generate both, fine or coarse surface finish by simple switch on the gear box.

TOOLING CHART

HOLDER	INSERT	SCREW	TORX
SFFM-V11	CIV-11-3-1	MHS-4	TX-15

MicroDrill-SOFD

Studding outlet flange drilling tool

MicroDrill-SOFD machine is specifically designed for this problem. It can fit even on 1" studding outlet flanges and, with its low-speed, high-torque operation, can drill holes up to 20 mm, making it perfect for precise drilling in tight spaces.

The locking shafts are 150 mm long as standard and 300 mm as optional. Other lengths are available on request.

Studding Outlet Flanges, also known as "pad flanges" (ANSI B16.5 ASTM A182), are often installed inside or outside vessels and tanks. A common issue arises when a stud breaks or shears, requiring the flange to be drilled out and re-threaded.



KEY FEATURES

UP TO 20 MM (2.4") DRILLING

Covers most heat exchanger tube sheets; suitable for various equipment types.

COMPACT BODY

Machine is lightweight and can be used in very tight spaces.

TORQUE-REACTIVE PLATFORM

Firm clamping absorbs machining forces, improving safety and control.

OPERATOR SAFETY

Designed for quick, safe plug removal with minimal risk.

WORKING RANGE		LOCKING RANGE		POWER		TORQUE	
12,5– 38,0 mm		According to the drawing		0,98 Hp		18 Nm / 300 RPM (55 Nm / 100 RPM*)	
0,492 – 1,496"						13,28 Ft-lbs / 300 RPM (40,57 Ft-lbs / 100 RPM*)	
AIR USE		BODY WIDTH		BODY HEIGHT		BODY LENGTH	
17 cfm	0,48 m ³ /min	1,73"	44 mm	10,82"	275 mm	12,2"	310 mm

*with 3x Speed Reducer

STABILITY AND DURABILITY



MiniDrill-SOFD features a robust steel frame for stability and durability. Precision locking plates ensure perfect centering on any flange size for stud drilling and thread prep. It also handles oversized holes with ease.

STANDARD TOOL



The machine is equipped with a standard ER25 collet chuck with the Weldon-type holder for quick and efficient tool changes. If needed, other configurations can be provided upon request to suit specific applications.



KRAIS Tube&Pipe Tools
Poland, 55-106 Zawonia, Czachowo 15
tel. +48 71 312 05 96, fax +48 71 387 03 32
email: export@krais.com
web: www.krais.com

 facebook.com/KraisTubeExpanders/
 linkedin.com/company/krais/

KRAIS tools
in action! 
youtube.com/kraistubeexpanders