

# SmartMill-8

Most powerful machine within this size range on the market today. Utilizes a powerful 2.2 kW (3 HP) pneumatic motor that is entirely engineered and manufactured by KRAIS. SmartMill-8 has a unique construction that has been specifically designed for the largest end prep systems.

- Self-centering 40 mm (1,57") one piece locking shaft.
- Only one mandrel and 6 Jaw sets needed to cover machines entire range.
- Wide clamps produce superior clamping force for chatter free end preps.
- Fully portable for on-site and Fab-shop work.

SmartMill-8 is available for sale or rent.



STANDARD WORKING RANGE		FEED STROKE	FREE SPEED	POWER	TORQUE		
APPLICATION RANGE	LOCKING RANGE						
40 - 219 mm	40 - 203,5 mm	50 mm	39 Rpm	3,0 hp	930 Nm		
1,574 - 8,622"	1,574 - 8,012"	2"			697 Ft.Lbs		
AIR USE		AIR PRESSURE		BODY DIMENSIONS		BODY WEIGHT	
75 cfm	2,2 m <sup>3</sup> /min	90 PSI	6,2 Bar	22 x 9,25 x 7,48"	560 x 235 x 190 mm	46 Lbs	21 kg

## LOCKING RANGES WITH STANDARD JAWS

### JAWS: SM-7

RANGE [MM]		RANGE [INCH]		SEGMENTS		
MIN	MAX	MIN	MAX	SM-42-0	SM-42-1	ML-42-A
40,0	55,0	1,575	2,165	SM-42-0		
55,0	69,5	2,165	2,736		SM-42-1	
69,5	84,0	2,736	3,307		SM-42-1	ML-42-A-75
84,0	98,5	3,307	3,878		SM-42-1	ML-42-A-150
98,5	113,5	3,878	4,469		SM-42-1	ML-42-A-225
113,5	128,5	4,469	5,059		SM-42-1	ML-42-A-300
128,5	143,5	5,059	5,650		SM-42-1	ML-42-A-300 ML-42-A-75
143,5	158,5	5,650	6,240		SM-42-1	ML-42-A-300 ML-42-A-150
158,5	173,5	6,240	6,831		SM-42-1	ML-42-A-300 ML-42-A-225
173,5	188,5	6,831	7,421		SM-42-1	ML-42-A-300 ML-42-A-225 ML-42-A-75
188,5	203,5	7,421	8,012		SM-42-1	ML-42-A-300 ML-42-A-225 ML-42-A-150

## OPTIONAL RIGHTANGLE CONFIGURATION

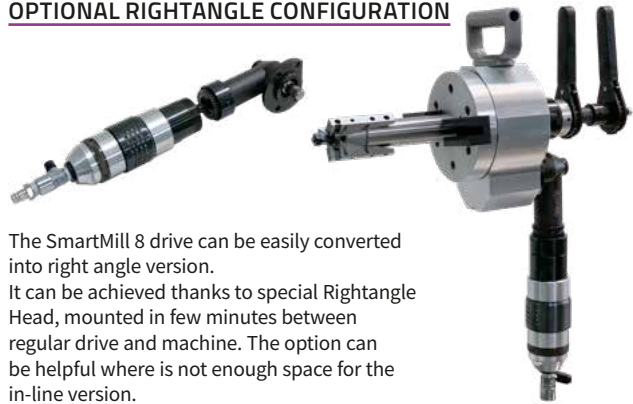

The SmartMill 8 drive can be easily converted into right angle version.

It can be achieved thanks to special Rightangle Head, mounted in few minutes between regular drive and machine. The option can be helpful where is not enough space for the in-line version.





## SMARTMILL-8 PERFORMANCE



The performance of the machine may vary depending on the skill of the operator, the materials, the conditions of the tools and the air supply system in case of pneumatic unit.

# SmartMill-8

## AVAILABLE HOLDERS

Facing	Inside bevelling and boring	Outside bevelling	J-Prep	Compound bevelling
				
F-45-90 BIT: 2CDI	IB-45-37 IB-45-10 BIT: 2CDI	OB-45-45 OB-45-37 OB-45-30 OB-45-10 BIT: 2CDI	JP-45-45 JP-45-37 JP-45-30 BIT: 2CDJ-5	CB-1037 (OTHERS ON REQUEST) BIT: CB-45
	F-CB-25+2-90 (ADJUSTABLE LENGTH FACING; HOLDER FOR THE LAND) BIT: XXXXXXX			

## ADVANTAGES OF SMARTMILL-8



**UNIQUE SHAFT DESIGN**  
40 mm (1,57") shaft, assures rigidity when machining heavy wall pipe. Only 6 set of jaws needed to cover the full locking range.



**POWERFUL MOTOR UNIT**  
SmartMill-8 is powered by powerful and efficient drives dedicated for our Lathe series bevelling machines. 39 rpm and 930 Nm (697 Ft.Lbs) torque on the cutter blade is a standard feature.



**LIGHTWEIGHT AND PORTABLE**  
The innovative design made it possible to produce lightweight and portable machine. Small weight of SmartMill-8 allows for fatigue-free operation in all conditions.



**HEAVY DUTY HANDLE**  
Machine is equipped with a solid and convenient aluminium handle.

## OPTIONALS



**RIGHT ANGLE HEAD**  
This right angle head allows for fastening drive in alternate positions. The useful option in tight spaces.



**30 MM SHAFT**  
Optional shaft to enable the machine to be used for smaller tubes. The shaft is supplied with complete jaws set to cover up to 2" ID.

## OPTIONAL ELECTRIC MOTOR UNIT

SmartMill-8E is electric version of SmartMill-8. The machine can cover the same pipe sizes and comes with the same cutting head. The electric motor with 4 speed mechanical gear box has also variable speed control and produce enormous torque on the cutter blade. Is interchangeable with pneumatic drive and can be purchased separately at any time. Take 5 min to replace from pneumatic to electric.



### DUDE-2000-4-SPEED

Motor free speed: 120-210-380-650 RPM  
 Motor power: 2000 Watt  
 Motor torque (on the 1st gear): 240 Nm (180 Ft.Lbs)  
 Machine feed stroke: 50 mm (2")  
 Cutter head speed: 8-14-25-43 rpm  
 Max torque on cutter blade (on the 1st gear): 3600 Nm (2664 Ft.Lbs)